



# USI

UNIVERSAL  
SMART  
INSTRUMENT

Intelligent Flow, Level and  
Water Quality Monitoring

# ONE INSTRUMENT. MULTIPLE APPLICATIONS.

The USI is designed to input several parameters on a single, easy to programme instrument – meaning the user saves on both purchasing and operating costs.

The Universal Smart Instrument (USI) is an innovative monitoring instrument and data logger that delivers multi-parameter measurement in a single device. Several standard instruments can therefore be replaced by a single USI in a wide range of clean water and wastewater applications.

Whilst giving highly accurate and reliable monitoring, the USI sets itself apart from traditional instrumentation by utilising powerful processors (as used in smartphones and satellite navigation) and dynamic software to display real-time data and graphs on its 7 inch high resolution touch screen. This provides the user with unrivalled accessibility and clarity of information.

Based on the robust and reliable industrial version of Windows, the USI is as intuitive and simple to operate as a home computer, which makes both programming and operation simple and efficient. With superior functionality and multiple communication outputs, measurement and control has never been so simple.



The USI is the result of four years research and development. Designed solely with the end user in mind it is the market leader in terms of both functionality and user experience.

## MULTIPLE MEASUREMENTS

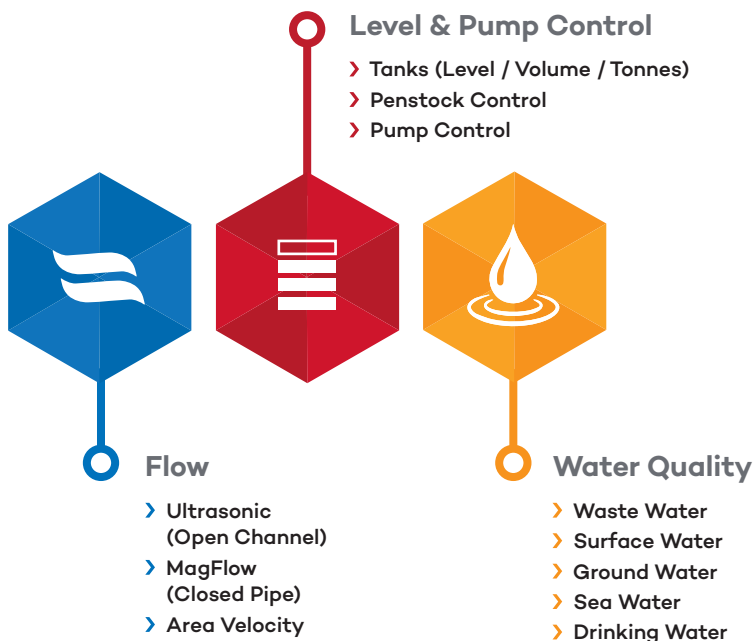

## WATER AND WASTEWATER SPECIALISTS

Built on its research and advanced capability Smart Storm has always been at the forefront of innovative products for the water and wastewater industries and has won many prestigious UK and European awards for its innovative technology.

# FEATURES AND BENEFITS

## One instrument - multiple sensors inputs

- › Reduced purchasing costs
- › Less space required
- › One instrument to programme
- › Multiple data collected in one place and format

## Smart sensors

- › Reliable and accurate measurement
- › Digital signal processing
- › Excellent signal quality in extreme operating environments

## Windows programming

- › Familiar and intuitive
- › Ease of set-up
- › User friendly
- › Licence included

## High capacity data logger

- › 20+ years storage
- › PC based reporting software included as standard

## Touch screen

- › Ease of operation and programming
- › Fast and simple navigation

## IP65 wall mounted

- › Weatherproof
- › Dustproof

## Multiple communications

- › USB – quick and convenient data download
- › GPRS – cloud upload and storage
- › GSM – text alerts
- › Ethernet – building management/remote PC
- › RS232 – RF transmitter

## Graphic colour display

- › User selectable colour schemes for various light conditions
- › Real-time and historical trend graphs instantly viewable on USI display
- › On screen echo profiling and tank mapping

## Multiple outputs

- › Six programmable relays as standard (expandable to 16)
- › Two 4-20mA outputs

# INFORMATION & DISPLAY FEEDBACK

Smart Storm recognises that most industrial control products are a nightmare to programme and often require specific training or hours of referencing complex user manuals. Confusion and uncertainty often reign when programming such instruments, and small single or multi-line displays give little information feedback to the user.

Hence, the USI has been developed to offer a new dimension in intuitive programming and information feedback. The software is wholly consumer orientated and intentionally designed to give the user a positive

programming experience, without confusion and without uncertainty. Programming options are instantly available through intuitive menus and give clear and precise options. Graphics are used to give clear choices when appropriate and parameter selection is simplicity itself. Programming pages are separated on the graphics display and once programmed users can simply and easily review their programme choices on a single display screen.

***Just like a smartphone, the USI menus are quick and simple to navigate!***



Beautifully Simple – Windows CE is recognised as the most reliable and easy to use operating system.

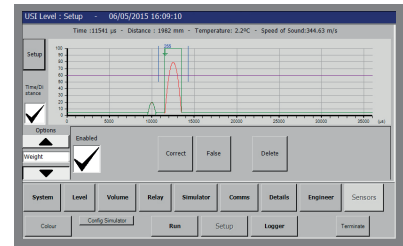

Echo Profiling

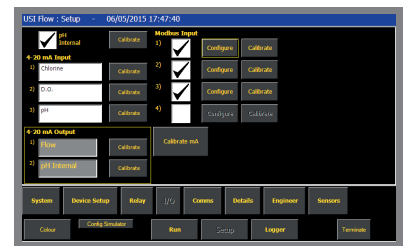

Input & Output Set-up

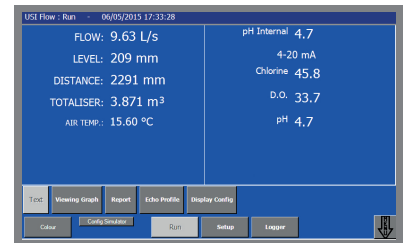

Live Flow Data



## Stunning touch screen displays

The USI gives an enhanced user experience through its 7 inch full colour TFT touch screen. This delivers sharp images, detailed real-time information and intuitive programming. The user even has the option to change background colours to compensate for different ambient light conditions (examples on opposite page).

### Real-time, On-screen Flow Trend Graph

The user can choose to display real-time data as either a running trend graph or as live text fields. Graphs can be scaled by the user to show trends over different time periods. Historical data from the internal data logger can be viewed on screen for instantaneous analysis without the need to download to a PC.

### Relay Set-up

The USI excels in its ease of programming; for example, relays can be simply programmed by selecting from a choice of fields accessed via drop down menus. The integral graphical simulator enables the user to simulate tank filling and emptying tanks, so the user may check his or her control process remotely.

### Tank Selection

In level applications, tank shapes are selected from a pre-programmed list and the chosen tank is displayed on screen as a three-dimensional image. All information is clearly displayed, thus avoiding confusion and uncertainty often found when programming other less advanced products.

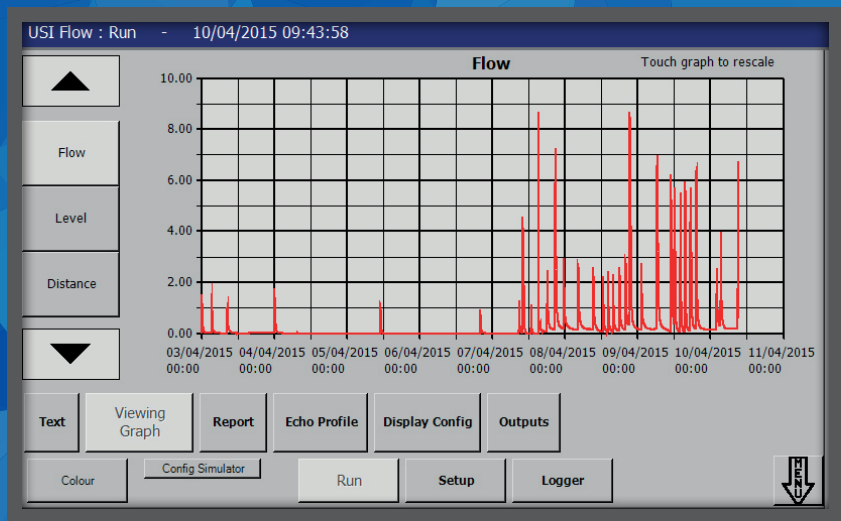

Flow Trend Graph

Relay Control					Pump				
Type	Tank	Delay	On	Off	Type	Order	Logic		
r1	Level	Tank1	1.00	5000 mm	1000 mm	Alternate	1	<input checked="" type="checkbox"/>	Disabled Level Volume Temperature Rate of rise Rate of fall Lost echo
r2	Level	Tank1	0.00	5000 mm	1000 mm	Alternate	2	<input checked="" type="checkbox"/>	
r3	Volume	Tank2	0.00	8000.000 m <sup>3</sup>	2000.000 m <sup>3</sup>	Fixed pump			
r4	Volume	Tank2	0.00	8500.000 m <sup>3</sup>	2000.000 m <sup>3</sup>	Duty assist	1	<input checked="" type="checkbox"/>	
r5	Rate of fall	Tank1	0.00	500 mm/s	0 mm/s	Fixed pump			
r6	Disabled								

Relay Set-up

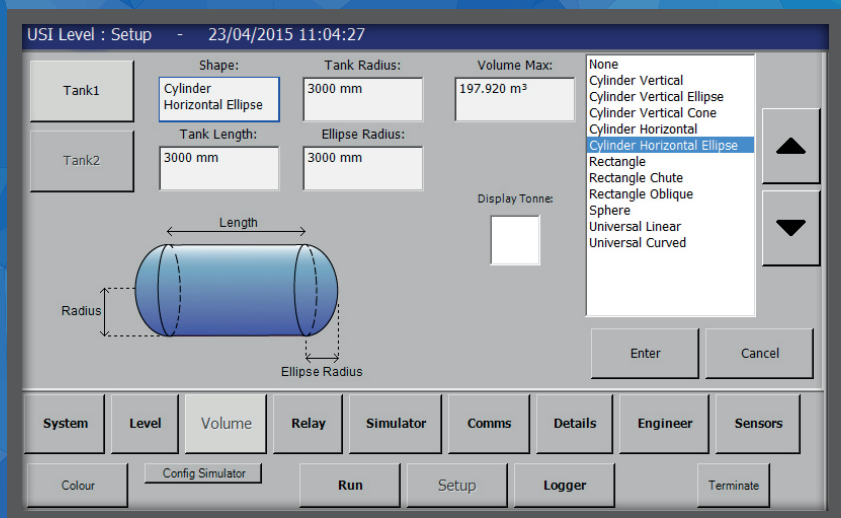

Tank Selection

# COMMS / USER APPLICATIONS

## Universal Communications

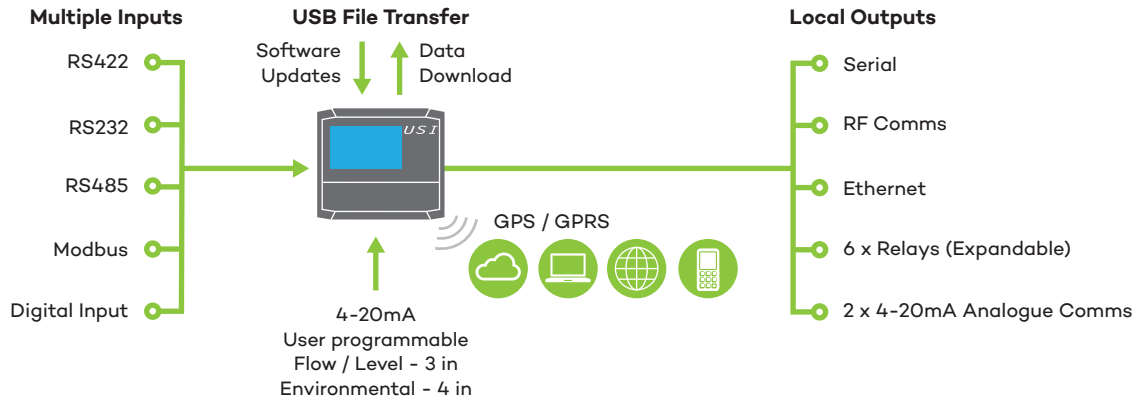

## Core Measurement Applications

### Flow

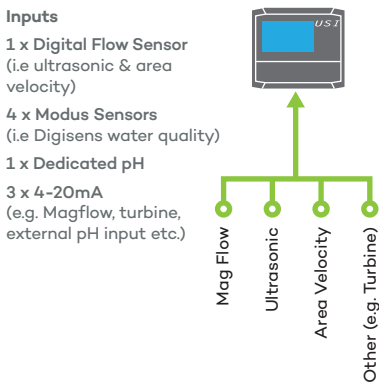

### Tank Level / Volume / Tonnes

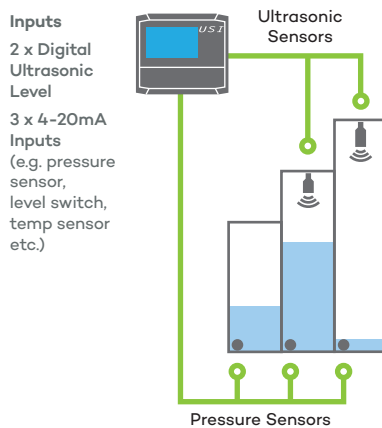

### Water Quality

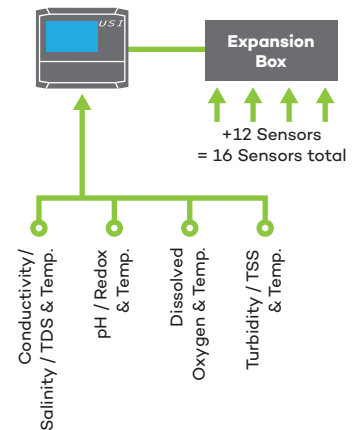

## Typical User Applications

### Pump Control

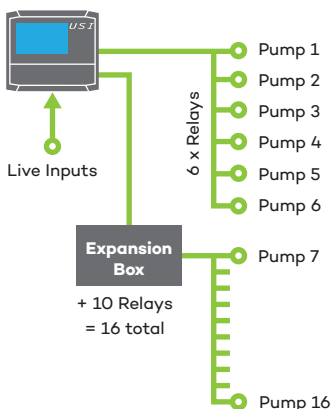

### Effluent

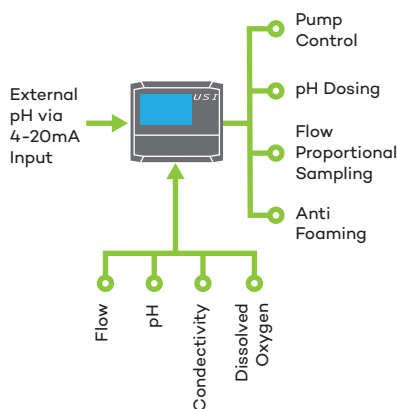

### Penstock Control

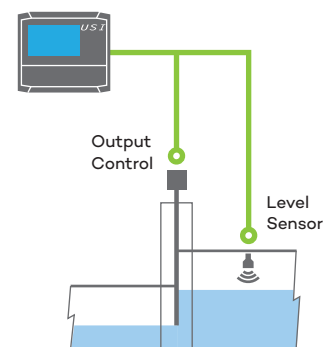

Note: For advice on how the advanced functionality of the US1 can be used in other specific applications please visit our website or contact our engineers.

# DIGITAL SENSORS

## Ultrasonic Sensors for Level and Flow

Smart Storm has developed the world's most advanced range of ultrasonic sensors which use Field Programmable Array Processors (FPGA) incorporated into the sensor body.

Known for high reliability the FPGA processor can be programmed directly from the USI and parameters such as sensor frequency, firing delay and signal amplitude can all be controlled and adjusted by the user. **All sensors benefit from integrated temperature sensors as standard.** Available in ranges from 3m to 20m the DIGISON range of ultrasonic sensors offer unrivalled performance.

## Water Quality Sensors

The DIGISENS range of water quality sensors has been developed with advanced digital signal processing within the sensor body for high accuracy measurement in a range of applications. Designed to be compact and robust, **all sensors benefit from integrated temperature sensors as standard.** With Modbus interface up to 4 sensors of any combination can be connected directly to the USI, or up to 16 via an additional input expansion module.

WATER QUALITY (DIGISENS SENSORS)	<p><b>PH / REDOX (ORP) &amp; TEMPERATURE</b></p> <p><b>SSPH Sensor</b>                      Range: pH 0-14 units                      Radox -1,000 - +1,000 mV</p>	<p><b>Applications:</b></p> <ul style="list-style-type: none"> <li>&gt; Pure mountain water &gt; 20 µS/cm</li> <li>&gt; Lakes and rivers 100 – 2000 µS/cm</li> <li>&gt; Seawater &gt; 50 mS/cm</li> <li>&gt; Wastewater &gt; 200 mS/cm</li> </ul>  <p>Data Sheet: SSPH</p>															
	<p><b>CONDUCTIVITY / SALINITY &amp; TEMPERATURE</b></p> <p><b>SSCS Sensor</b>                      Range: 0-200 mS/cm</p>	<p><b>Applications:</b></p> <ul style="list-style-type: none"> <li>&gt; Urban wastewater treatment</li> <li>&gt; Industrial effluent treatment</li> <li>&gt; Surface water monitoring</li> <li>&gt; Sea water</li> <li>&gt; Drinking water</li> </ul>  <p>Data Sheet: SSCS</p>															
	<p><b>NEPHELOMETRIC TURBIDITY &amp; TEMPERATURE</b></p> <p><b>SSNT Sensor</b>                      Range: 0-4000 NTU or 0-4500 mg/L</p>	<p><b>Applications:</b></p> <ul style="list-style-type: none"> <li>&gt; Urban wastewater treatment (inlets/outlet controls)</li> <li>&gt; Sanitation network</li> <li>&gt; Industrial effluent treatment</li> <li>&gt; Surface water monitoring</li> <li>&gt; Sea water</li> <li>&gt; Drinking water</li> </ul>  <p>Data Sheet: SSNT</p>															
	<p><b>OPTICAL DISSOLVED OXYGEN &amp; TEMPERATURE</b></p> <p><b>SSDO Sensor</b>                      Range: 0,00-20,00 mg/L, 0,00-20,00 ppm, 0-200%</p>	<p><b>Applications:</b></p> <ul style="list-style-type: none"> <li>&gt; Urban wastewater treatment</li> <li>&gt; Industrial effluent treatment</li> <li>&gt; Surface water monitoring</li> <li>&gt; Drinking water</li> </ul>  <p>Data Sheet: SSDO</p>															
LEVEL	<table border="1"> <thead> <tr> <th></th> <th>Range</th> <th>Frequency</th> </tr> </thead> <tbody> <tr> <td>DIGISON 3</td> <td>3m</td> <td>150kHz</td> </tr> <tr> <td>DIGISON 6</td> <td>6m</td> <td>80kHz</td> </tr> <tr> <td>DIGISON 10</td> <td>10m</td> <td>60kHz</td> </tr> <tr> <td>DIGISON 20</td> <td>20m</td> <td>40kHz</td> </tr> </tbody> </table> <p>(All models include temperature sensors)</p>		Range	Frequency	DIGISON 3	3m	150kHz	DIGISON 6	6m	80kHz	DIGISON 10	10m	60kHz	DIGISON 20	20m	40kHz	<p><b>Applications:</b></p> <ul style="list-style-type: none"> <li>&gt; Liquid and solid level</li> <li>&gt; Pump Control</li> <li>&gt; Penstock Control</li> </ul>  <p>Data Sheet: DIGISON 3-20</p>
	Range	Frequency															
DIGISON 3	3m	150kHz															
DIGISON 6	6m	80kHz															
DIGISON 10	10m	60kHz															
DIGISON 20	20m	40kHz															
FLOW	<p><b>Open Channel</b></p> <table border="1"> <thead> <tr> <th>Model</th> <th>Range</th> <th>Frequency</th> </tr> </thead> <tbody> <tr> <td>DIGISON 3</td> <td>3m</td> <td>150kHz</td> </tr> <tr> <td>DIGISON 6</td> <td>6m</td> <td>80kHz</td> </tr> </tbody> </table> <p>(All models include temperature sensors)</p> <p><b>Closed Pipes</b></p> <p>FLOWMAG 3000                      Range: 0.028-48858 m<sup>3</sup>/h                      Pipe sizes: DN10-1200mm / DN 3/8-48"</p> <p>Liquid temp. 0-150°C</p>	Model	Range	Frequency	DIGISON 3	3m	150kHz	DIGISON 6	6m	80kHz	<p><b>Applications:</b></p> <ul style="list-style-type: none"> <li>&gt; Open Channel Flow</li> <li>&gt; Closed Channel Flow</li> <li>&gt; Effluent Flow</li> <li>&gt; Process Flow</li> </ul>  <p>Data Sheets: DIGISON 3-6 FLOWMAG 3000</p>						
Model	Range	Frequency															
DIGISON 3	3m	150kHz															
DIGISON 6	6m	80kHz															
AREA VELOCITY	<p><b>SSAV</b> 60mA / 5 secs</p> <p>Dual-Wave Ultrasonic Doppler technology.                      High resolution 15PSI stainless steel pressure transducer.                      Measures flow in channels up to 9m without loss of depth accuracy.</p>	<p><b>Applications:</b></p> <ul style="list-style-type: none"> <li>&gt; Open Channel Flow</li> <li>&gt; Surveys</li> <li>&gt; Irrigation control</li> </ul>  <p>Data Sheet: SSAV</p>															

Note: Measurement ranges are based on optimum conditions. Please see relevant data sheets for full sensor specifications.

# USI SPECIFICATIONS

## STANDARD SPECIFICATIONS

Display	7" High Resolution Full Colour TFT LCD Graphics Display 800 x 480 Anti-Glare
Programming	Touch Screen or Remote Keypad via USB Port
Operating System	Windows CE 6.0 R3 (licence included)

## PHYSICAL

Dimensions (mm)	234 (H) x 264 (W) x 142 (D) mm
Ratings	IP65/DIN VDE 60529 NEMA 12
Approvals	ABS Lid UL94 HB/L6 Polyamide Base UL94 VO/1
Mounting	4 Fixing Holes (optional wall brackets or DIN-rail holder)

## POWER

Supply (AC)	Universal Power Supply 85 - 264V - 15W
Supply (DC)	18 - 36V (optional)

## ELECTRONIC PERFORMANCE

Processors	Dual Processors with SPARTAN 3AN FPGA and ARM CPU
Internet Connectivity	Via Ethernet, GPRS Modem or optional Wi-Fi
Logger	512MB NAND Flash plus Internal SD Card
Temperature Range	-20 to +70°C (-4 to +176°F)

## STANDARD FEATURES

- › User Selectable Display
- › Trend Graph with Zoom Control
- › Simple, fast and intuitive programming
- › Tab based Menu Selection
- › 6 different User Configurable Display Colours for different light conditions
- › Up to 20 years Logging Capacity
- › Historical Data Viewable on USI Display without the need to download to PC
- › USB Data download
- › Cloud based Data Retrieval\*
- › GSM Message Alerts\*
- › Internal Address Book for GSM Message Alerts
- › Windows based Data Presentation Software included for PC Report Generation
- › Fault and Event Logging
- › Echo Profiling and Tank Mapping\*\*
- › Easily modified to meet bespoke programming requirements
- › Units: SI and Imperial
- › Service Reminder Alarm
- › 6 LEDs to indicate Relay Status
- › 3 layers of Password Protection

## USI LEVEL

USI LEVEL	USI FLOW	USI WATER QUALITY
<b>Dedicated Measurement Inputs</b>		
<ul style="list-style-type: none"> <li>› Ultrasonic Level (2 channels)</li> <li>› Displays Level, Distance, Volume and Tonnes</li> </ul>	<ul style="list-style-type: none"> <li>› Ultrasonic Open Channel Flow (single channel)</li> <li>OR</li> <li>› Area Velocity Flow (single channel)</li> </ul>	<ul style="list-style-type: none"> <li>› 4 Modbus Sensors (4 channels) in any combination from: pH, ORP, Dissolved Oxygen, Conductivity, Salinity, Turbidity, Suspended Solids, Temperature</li> <li>› Expansion Modules for up to 16 Sensors</li> </ul>
<ul style="list-style-type: none"> <li>› pH Sensor (single channel)</li> </ul>	<ul style="list-style-type: none"> <li>› pH Sensor (single channel)</li> </ul>	

## Auxiliary Measurement Inputs

<ul style="list-style-type: none"> <li>› 4-20mA or 0-20mA - 3 channels (isolation optional) 0.1% resolution</li> <li>› Configurable for numerous inputs from other devices including: Pressure, Specific Gravity, pH, ORP, Dissolved Oxygen, Chlorine, Temperature</li> <li>› 4-20mA channels configurable as Float Switch Inputs</li> </ul>	<ul style="list-style-type: none"> <li>› 4-20mA or 0-20mA - 3 channels (isolation optional) 0.1% resolution</li> <li>› Configurable for numerous inputs from other devices including: pH, ORP, Dissolved Oxygen, Chlorine, Temperature, Mag Flow, Turbine Flow</li> <li>› User defined axis over 4-20mA range</li> </ul>	<ul style="list-style-type: none"> <li>› 4-20mA or 0-20mA - 4 channels (isolation optional) 0.1% resolution</li> </ul>
<ul style="list-style-type: none"> <li>› Digital Input</li> </ul>	<ul style="list-style-type: none"> <li>› Digital Input</li> </ul>	<ul style="list-style-type: none"> <li>› Digital Input</li> </ul>

## Outputs

<ul style="list-style-type: none"> <li>› 4-20mA or 0-20mA - 2 channels, isolated, expandable to 16 outputs</li> <li>› Configurable to any input</li> </ul>	<ul style="list-style-type: none"> <li>› 4-20mA or 0-20mA - 2 channels, isolated</li> <li>› Configurable to any input</li> </ul>	<ul style="list-style-type: none"> <li>› 4-20mA or 0-20mA - 2 channels, isolated, expandable to 16 outputs</li> <li>› Configurable to any input</li> </ul>
<ul style="list-style-type: none"> <li>› Digital Output</li> </ul>	<ul style="list-style-type: none"> <li>› Digital Output</li> </ul>	<ul style="list-style-type: none"> <li>› Digital Output</li> </ul>

## Comms

<ul style="list-style-type: none"> <li>› Ethernet: 100BaseT, 10BaseT for Building Management System (BMS) or data retrieval to remote PC</li> <li>› USB External (2 channels)</li> <li>› USB Stick: USB2.0, FAT file system</li> </ul>	<ul style="list-style-type: none"> <li>› Ethernet: 100BaseT, 10BaseT for Building Management System (BMS) or data retrieval to remote PC</li> <li>› USB External (2 channels)</li> <li>› USB Stick: USB2.0, FAT file system</li> </ul>	<ul style="list-style-type: none"> <li>› Ethernet: 100BaseT, 10BaseT for Building Management System (BMS) or data retrieval to remote PC</li> <li>› USB External (2 channels)</li> <li>› USB Stick: USB2.0, FAT file system</li> <li>› RS232</li> </ul>
<ul style="list-style-type: none"> <li>› ModbusRS485*, RTU and ASCII, Baudrate: 9600 or 19200, Parity: none, even or odd, DataBits: 8, StopBits: 1 or 2</li> </ul>	<ul style="list-style-type: none"> <li>› Modbus RS485*, RTU and ASCII, Baudrate: 9600 or 19200, Parity: none, even or odd, DataBits: 8, StopBits: 1 or 2</li> </ul>	<ul style="list-style-type: none"> <li>› Modbus RS485*, RTU and ASCII, Baudrate: 9600 or 19200, Parity: none, even or odd, DataBits: 8, StopBits: 1 or 2</li> </ul>
<ul style="list-style-type: none"> <li>› RS232: GPRS Modem or RF Link</li> </ul>	<ul style="list-style-type: none"> <li>› RS232: GPRS Modem or RF Link</li> </ul>	<ul style="list-style-type: none"> <li>› RS232: GPRS Modem or RF Link</li> </ul>

## Relays

<ul style="list-style-type: none"> <li>› 6 Fully Programmable Relays (10A @230Vac)</li> </ul>	<ul style="list-style-type: none"> <li>› 6 Fully Programmable Relays (10A @230Vac)</li> </ul>	<ul style="list-style-type: none"> <li>› 6 Fully Programmable Relays (10A @230Vac) expandable to 16</li> </ul>
---	---	--

## Additional Features

<ul style="list-style-type: none"> <li>› Graphical Selection of 9 Tank Shapes</li> <li>› 32-point Lookup Table for non-standard tanks</li> <li>› Fast access to on-screen 7-day Report</li> <li>› Advanced Programmable Pump Control</li> <li>› Pump Control Simulator</li> <li>› Real-time Echo Profiling and Tank Mapping on USI Display</li> <li>› Data Logging of all Parameters</li> <li>› User Naming of Tanks</li> <li>› Differential Level</li> </ul>	<ul style="list-style-type: none"> <li>› Real-time Echo Profiling and Tank Mapping on USI Display</li> <li>› Fast access to on-screen 7-day Report</li> <li>› 8 Primary Devices, Manning Formula and 32-point Lookup Table</li> <li>› Penstock Control</li> <li>› Real-time Echo Profiling and Tank Mapping on USI Display</li> <li>› Data Logging of all Parameters</li> </ul>	<ul style="list-style-type: none"> <li>› Data Logging of all Parameters</li> <li>› Fast access to on-screen 7-day Report</li> <li>› User Naming of all Measurement Inputs</li> <li>› Integral Temperature Sensors on all Modbus Probes</li> </ul> <p>Notes: * Requires external modem ** USI flow and level only *** Via optional daughter board</p>
---	---	--