

Operating instructions

Product: Multi-layer diaphragm pump

Type: C 410.2 - 70 ML
C 410.2 - 135 ML
C 410.2 - 500 ML
C 410.2 - 1200 ML

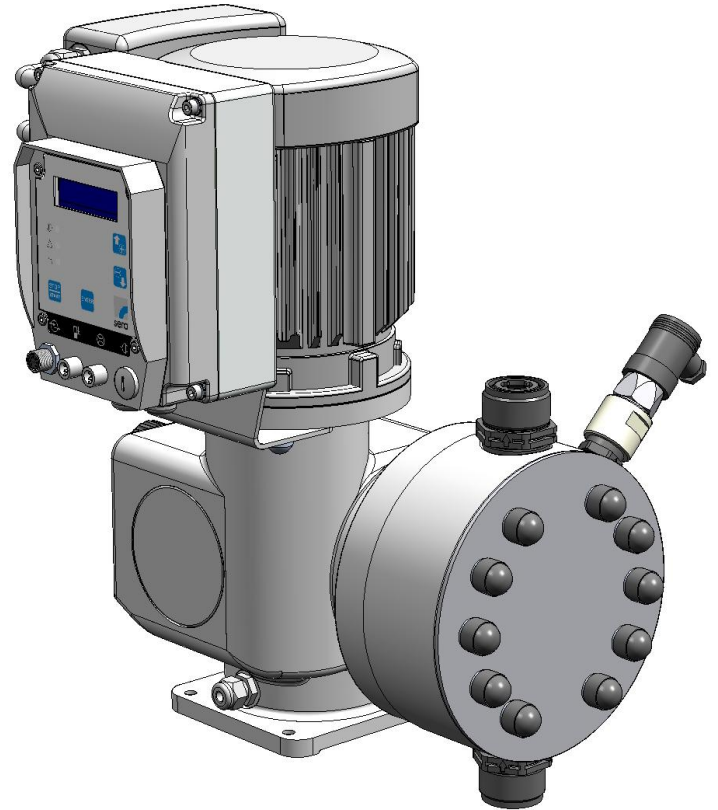

Please state here the exact type and serial number of your pump (can be read off the type plate on the pump)
Type:
Serial No.:
These data are important in case of queries or for ordering spare- and wearing parts and must absolutely be stated.

Manufacturer:
**Seybert & Rahier
GmbH + Co. Betriebs-KG**
sera-Straße 1
34376 Immenhausen
Germany
Tel. +49 5673 999-00
Fax. +49 5673 999-01
www.sera-web.com
info@sera-web.com

CAUTION ! Keep the operating instructions for future application!	
---	---

Operating instructions

Table of contents:

1	Quickstart	4	4.11	Personal protection for maintenance and service	9
1.1	Mains connections	4	4.12	Utilities	9
1.2	Operating elements.....	4	5	Transport and intermediate storage	9
1.3	LED operation indicators.....	4	5.1	General	9
1.4	Key operation.....	5	5.2	Transport.....	9
1.5	Factory settings	5	5.3	Storage	9
1.6	Control inputs and outputs	5	6	Components of the multi-layer diaphragm pump....	10
1.6.1	Control via a contact signal	5	7	Technical data.....	11
1.6.2	Control via an analog signal	5	7.1	Dimensions	11
1.7	Selecting the operating mode.....	5	7.2	Performance data.....	13
2	Allgemein.....	6	8	Functional description.....	14
3	Types.....	6	8.1	General	14
3.1	Type code.....	6	8.2	Components of the multi-layer diaphragm pump 410.2.....	14
3.2	Type plate.....	6	8.2.1	Stroke mechanism	14
3.3	Materials.....	7	8.2.2	Electronics (operating panel).....	14
3.4	Viscosity, pumped medium	7	8.2.3	Stroke length adjustment	15
3.5	Dosing range	7	8.2.4	Built-in pump	17
3.6	Noise measurement.....	7	8.2.5	Pump body	17
4	Safety instructions	7	8.2.6	Suction/pressure valve	18
4.1	Note on quality.....	7	8.2.7	Diaphragm rupture monitoring (with pressure switch) ..	18
4.2	Marking of notes	7	8.3	Drive motor.....	18
4.2.1	Marking of notes in these operating instructions.....	7	8.3.1	Start-up	18
4.2.2	Marking of notes on the product.....	8	8.3.2	Motor protection	18
4.3	Personnel qualification and training.....	8	8.3.3	Maintenance of the drive motor	19
4.4	Dangers in case of inobservance of the safety instructions	8	8.3.4	Restart.....	19
4.5	Safety conscious working.....	8	9	Assembly / Installation	19
4.6	Safety instructions for the owner / operator	8	9.1	Installation instructions	19
4.7	Safety instructions for maintenance-, inspection and installation work	8	9.1.1	Provide overpressure protection.....	20
4.8	Arbitrary modification and spare parts production ...	8	9.1.2	Prevent a backflow of the pumped medium	21
4.9	Improper operation.....	8	9.1.3	Eliminate undesired siphoning.....	21
4.10	Intended use	9	9.1.4	How to ensure an air-free suction.....	22
			9.1.5	Install the empty-tank alarm	22
			9.1.6	How to avoid draining of the suction line.....	23
			9.1.7	Line strainer	23
			9.1.8	Suction via a siphon pipe.....	24
			9.1.9	In case of easily degassing pumped media	24
			9.1.10	Damping of the pulsation	24
			10	Electric connections	26
			10.1	Mains connections.....	26
			10.2	Connection mains pipe	26
			10.3	Electrical interfaces	27
			10.3.1	Control inputs and outputs.....	27
			10.3.2	Level input with pre-alarm and dry run	29
			10.3.3	Input for flow control and flow meter.....	29

Operating instructions

11	Operation.....	29	14	Fault analysis and corrective action.....	55
11.1	Operating elements.....	29	14.1	Analysis of the plain text error messages (electronics).....	56
11.2	LED operation indicators.....	29	14.2	Analysis of other faults	58
11.3	Key operation.....	30	15	Foreseeable misuse	59
11.4	Parameter table	31	15.1	Transport.....	59
11.5	Menu	32	15.2	Assembly and installation	59
11.5.1	Screen "Operating messages"	32	15.3	Start-up	59
11.5.2	Fault and warning messages	32	15.4	Operation	59
11.5.3	Screen "Main menu"	33	15.5	Maintenance/Repair	59
11.5.4	Value entry.....	33	15.6	Cleaning.....	60
11.5.5	Menu guide.....	34	15.7	Shut-down	60
11.6	Selecting the operation mode.....	38	15.8	Disassembly.....	60
11.7	Additional settings for the operation mode	38	15.9	Disposal	60
11.7.1	Additional settings for the ANALOG operation mode ..	38	16	Shut-down	60
11.7.2	Additional settings for the PULSE mode	40	17	Disposal	60
11.7.3	Additional settings for the BATCH mode.....	41	17.1	Dismantling and transport.....	60
11.7.4	Settings for the EXTERNAL operation mode.....	42	17.2	Complete disposal.....	60
11.8	Configuring the inputs and outputs.....	42	18	Technical documentation pressure switch	61
11.8.1	Digital input 01	43			
11.8.2	Digital/analog inputs 02 and 03	43			
11.8.3	Outputs 01 and 02	43			
11.9	Flow rate indicator	44			
11.10	Calibration	45			
11.11	System	46			
11.12	Totalizer.....	47			
11.13	Password.....	47			
11.14	Info	47			
11.15	Extras	47			
11.15.1	Slow-Mode.....	47			
11.15.2	Dosing monitoring.....	48			
11.15.3	Diaphragm rupture detection	48			
11.15.4	Level monitoring	49			
12	Maintenance	50			
12.1	Wearing parts	50			
12.2	Spare parts	50			
12.3	Spare- and wearing parts.....	51			
12.4	Changing the diaphragm.....	53			
12.4.1	General	53			
12.4.2	Changing the diaphragm	53			
12.5	Oil change	55			
13	Lubricants in stroke mechanism.....	55			

Operating instructions

1 Quickstart

“Quickstart” is used to start-up the pump quickly without having read the operating instructions in detail.

CAUTION !



The Quickstart does not claim to be complete and does not relieve the user from reading the complete instructions!

1.1 Mains connections

The **sera** – diaphragm pump is delivered ready for connection with a 2m mains cable and a CEE-socket/ 16A 5-poles 6h. The diaphragm pump is designed for an operating voltage range of 380 – 420 V, 50/60 Hz.

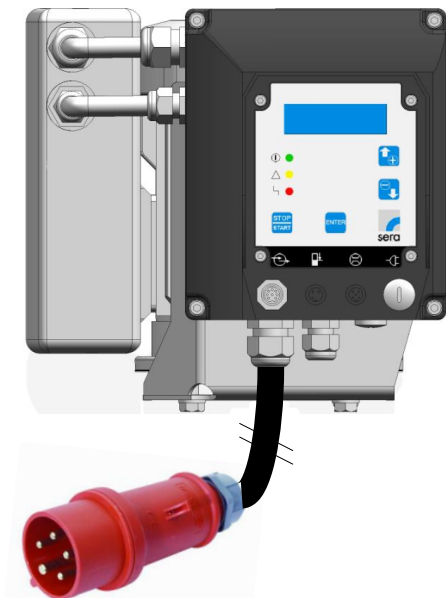

Fig. 01 Mains Connections

The mains connection requires 3~ 400V + neutral conductor + protective conductor.

The leakage current against earth amounts to approx. 7 mA.

Recommended protection: 3-poles automatic fuse C10A

CAUTION !



Only operate the pump when it is connected to an earthed power supply!

CAUTION !



The pump restarts in the selected operating mode after the power supply was switched on or a power supply recovery following a mains failure!

1.2 Operating elements

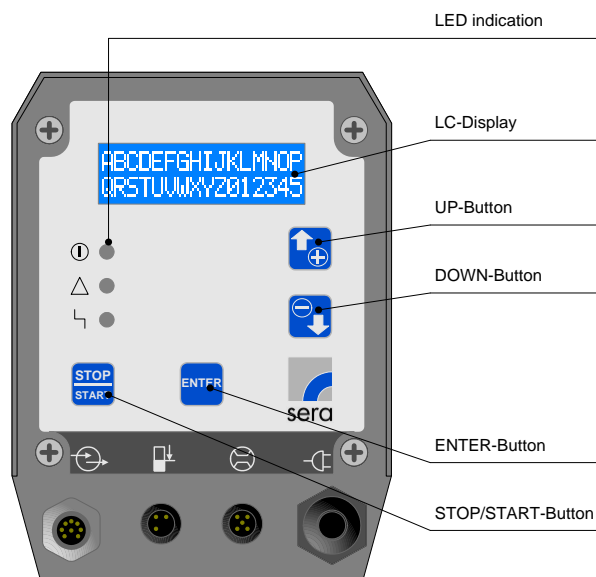

Fig. 02 (Electronics control panel)

1.3 LED operation indicators

Three light-emitting diodes (LED) indicate the status of the pump.

Green: Operation and stroke indicator



When switching on the pump, the green LED lights steadily. The operation indicator works in combination with a stroke indicator; during pump operation, the LED flashes in accordance with the current stroke frequency.

Yellow: Warning indicator



The yellow LED indicates all occurring warning messages (see Tab. 09). The warning is not only indicated by the LED but also as plain text in the LCD display.

Red: Fault indicator



The red LED indicates all occurring faults (see Tab. 09). The fault is not only indicated by the LED but also as plain text in the LCD display.

Operating instructions

1.4 Key operation

Operation of the pump is performed with 4 keys:



STOP/START key

After connection to the power supply, the pump is switched ON/OFF using the STOP/START key.



ENTER key

You can use the ENTER key to open and confirm value input fields and to select menu items.



UP / DOWN key

Using the UP/DOWN key, you can scroll the different menu items / menu levels and select the display of various operating messages.
During parameter adjustment, the UP key is used to increase the parameter value and the DOWN key is used to decrease the parameter value.

1.5 Factory settings

The factory setting of the pump electronics is specified in Chapter 11.4.

1.6 Control inputs and outputs

1.6.1 Control via a contact signal

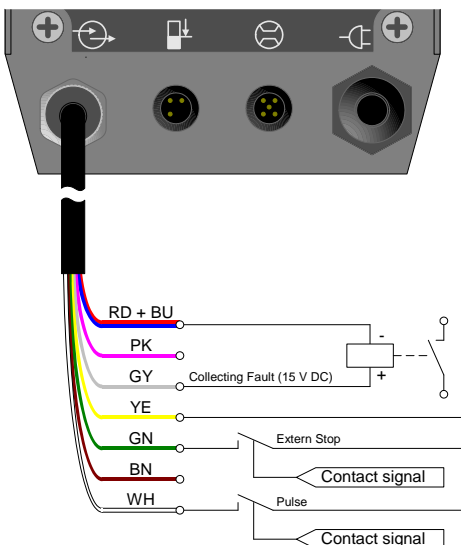

Fig. 03 (Control of digital inputs via a potential-free contact signal and control of a relay via an output of the dosing pump)

1.6.2 Control via an analog signal

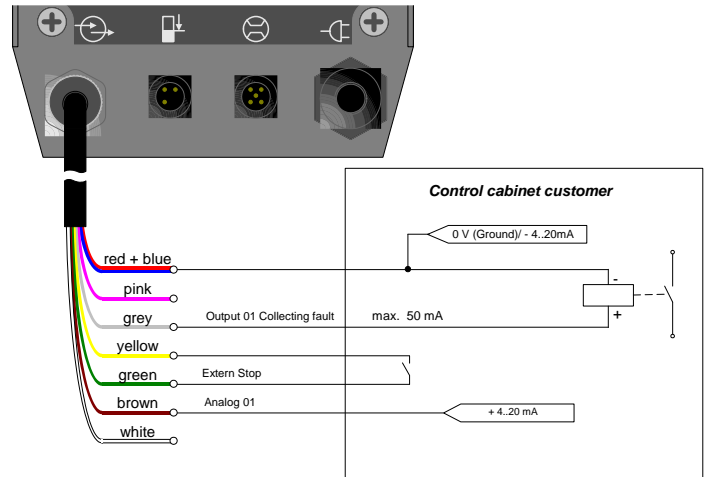
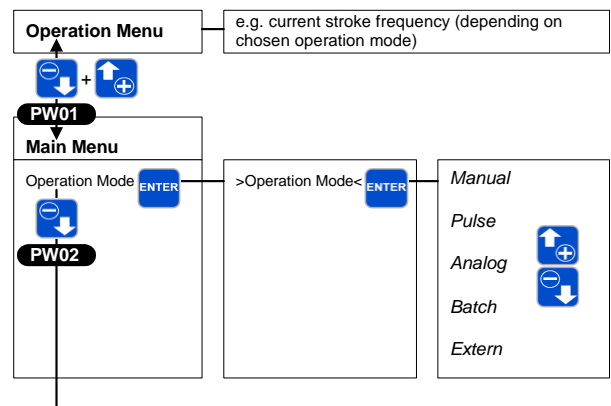

Fig. 04 (Control of analog/digital inputs via an analog signal, potential-free contact signal and control of a relay via an output of the dosing pump)

1.7 Selecting the operating mode

Proceed as follows to select the operating mode:

1. Input the password PW01 (factory setting 9990) to release the programming levels.
2. Change the operating mode.



PW01 Locking by Password 01 (pre setting ex work: 9990, not activated)

PW02 Locking by Password 02 (pre setting ex work: 9021)

Operating instructions

2 Allgemein

Before commissioning and during operation of the **sera** – multi-layer diaphragm pump the respective regulations valid at the place of installation are to be observed.

The **sera** – multi-layer diaphragm pump is delivered ready for installation. Carefully read these instructions and especially the safety instructions herein contained before installation and initial start-up of the pump.

3 Types

3.1 Type code

Example:

Multi-layer diaphragm pump type **C 410.1-70 ML**

C	410.2	70	ML
----------	-------	----	----

Pump control

C controllable

C	410.2	70	ML
----------	--------------	----	----

Indication of model range/stroke mechanism

C	410.2	70	ML
----------	-------	-----------	----

Angabe des Nennförderstroms

This number states the nominal delivery rate in litres/hour.
(standard version referring to water)

C	410.2	70	ML
----------	-------	----	-----------

Indication of the pump design

ML Multi-layer diaphragm pump

3.2 Type plate

Each **sera** multi-layer diaphragm pump is factory provided with a type plate. The following information can be found on this type plate.

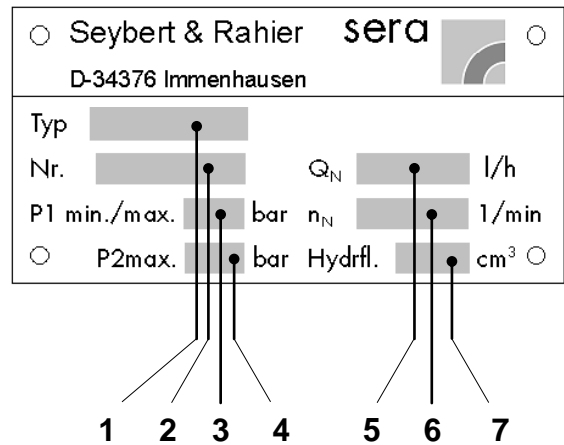

Fig. 05 Type plate

Explanation of the indications on the type plate		
1	Type	Pump type
2	No.	Serial number of the pump
3	P ₁ min/max [bar]	Minimum/maximum permissible pressure in the pump inlet Minimum/maximum permissible pressure in the inlet cross section which the pump can be used for. Please consider that pressure depends on rotation speed, delivery rate, temperature and static pressure at the inlet.
4	P ₂ max [bar]	Maximum permissible pressure in the pump outlet Maximum permissible pressure in the outlet cross section which the pump can be used for. Please consider that pressure depends on rotation speed, delivery rate, temperature and static pressure at the outlet.
5	Q _N l/h	Nominal delivery rate Delivery rate which the pump was ordered for, based on the nominal rotation speed n _N , the nominal delivery height p ₂ max. and the delivery medium stated in the supply contract.
6	n _N 1/min	Nominal stroke frequency
7	Hydrfl. [cm ³]	<i>Not applicable</i>

Table 01 Explanation of type plate

Operating instructions

3.3 Materials

The materials used are stated in the order confirmation.

3.4 Viscosity, pumped medium

The multi-layer diaphragm pump is suitable for fluids with viscosities < 100 mPas.

3.5 Dosing range

The delivery rate of the multi-layer diaphragm pump can be set manually via the stroke length adjustment (0...100%).
The linear dosing range is between 20% and 100%.

3.6 Noise measurement

According to DIN 45635 the sound pressure level measured of the multi-layer diaphragm pumps is between 50 and 60 dB (A).

4 Safety instructions

4.1 Note on quality

Observance of these operating instructions and, in particular, the safety instructions, helps to

- avoid dangers to persons, machines, and environment
- increase the reliability and service life of the pump and the entire system
- reduce repair cost and downtime.

The **sera** quality management system is certified according to ISO 9001:2000.

The **sera** – multi-layer diaphragm pump complies with the valid safety requirements and accident prevention regulations.

CAUTION !



Always keep these operating instructions within reach at the place of installation of the pump.

CAUTION !



Pay attention to the safety data sheet of the pumped medium! The owner must take corresponding accident prevention measures to protect operating personnel from danger through the pumped media used!

4.2 Marking of notes

4.2.1 Marking of notes in these operating instructions

Special notes in these operating instructions are marked with the general danger symbol



(safety symbol in compliance with DIN 4844 – W9)

The safety sign appears in the following cases:

- If improper observance or non-observance of the operating manual, work instructions, specified operating procedures and similar can lead to personal injury or accidents.
- If improper observance or non-observance of the operating manual, work instructions, specified operating procedures and similar can lead to damage to property.
- Due to danger of causticization personnel must wear protective clothing (safety goggles, safety gloves and safety apron) for maintenance and repair work on parts which come into contact with hazardous products or for changing the containers.

Operating instructions

4.2.2 Marking of notes on the product

Symbols which are directly attached to the pump, e.g. arrows for direction of rotation or symbols for fluid connections are to be observed and kept in legible condition.

4.3 Personnel qualification and training

The personnel who operate, maintain, inspect and install the multi-layer diaphragm pump must be suitably qualified. Range of responsibility, and supervision of the personnel are to be clearly defined by the owner. If the personnel do not have the knowledge required it is to be trained and instructed accordingly. If required such a training can be carried out by the manufacturer /supplier upon order of the owner. The owner must also ensure that the personnel have understood the operating instructions.

4.4 Dangers in case of inobservance of the safety instructions

Inobservance of these safety instructions can result in danger to persons, hazards to the environment and damage to the pump.

Inobservance can result in:

- Failure of important functions of the pump/system
- Inobservance of prescribed methods for maintenance and servicing
- Danger to persons through electrical, mechanical and chemical influences
- Hazards to the environment through leaking dangerous media

4.5 Safety conscious working

The safety instructions specified in this operating manual, the national regulations for accident prevention, the safety regulations for the pumped medium valid at the place of installation as well as internal working-, operating-, and safety instructions of the owner are to be observed.

4.6 Safety instructions for the owner / operator

Leaking pumped media and utilities must be disposed off in such a way that any danger to persons and hazards to the environment are excluded. The legal regulations are to be observed.

Dangers through electric energy are to be precluded.

4.7 Safety instructions for maintenance-, inspection and installation work

The owner must ensure that all maintenance-, inspection- and installation work are exclusively carried out by authorized and qualified personnel who have read the operating instructions carefully.

The spare parts and utilities used must comply with the requirements of the respective operating conditions.

All screwed connections and connections may only be removed when the system is not under pressure.

4.8 Arbitrary modification and spare parts production

Modification to and changement of the pump are only permitted after previous agreement of the manufacturer. Original spare parts and accessories approved by the manufacturer increase safety.

CAUTION !



If non-approved parts are used or if the pump (e.g. drive motor) is modified arbitrarily the manufacturer refuses any liability claims.

4.9 Improper operation

Operational reliability of the supplied multi-layer diaphragm pump is only guaranteed if the product is used as intended, according to the descriptions in Chapter 4.10 of these operating instructions.

Operating instructions

4.10 Intended use

The **sera** – diaphragm pump is only to be deployed according to the intended purpose stated in the product description and the acceptance test certificate.

If the multi-layer diaphragm pump is to be used for other applications, then the suitability of the pump for the new operating conditions must be discussed with **sera** beforehand!

Criteria for the proper use of the multi-layer diaphragm pump

- Observe characteristics of the pumped medium (please see safety- and product data sheet of the pumped medium used – the safety data sheet is to be provided by the supplier / owner of the pumped medium)
- Resistance of the materials which come in contact with the pumped medium
- Operating conditions at the place of installation
- Pressure and temperature of the pumped medium
- Voltage supply

4.11 Personal protection for maintenance and service

In order to avoid risks to health, the provisions of the German Ordinance on Hazardous Substances (GefStoffV) (§14 Safety Data Sheet) and relevant national safety regulations for the pumped medium must strictly be adhered to.

In case of an incident pay attention to the following leaking media:

- fluids
- vapours
- noise emissions (sound level)

Emissions are to be monitored by corresponding monitoring systems.

CAUTION !



Wear protective clothing, gloves, and a face protecting and breathing mask.

CAUTION !



Personal protective equipment must be provided by the owner!

4.12 Utilities

If not agreed otherwise in the contract conditions, the **sera** multi-layer diaphragm pump is always supplied with the necessary utilities.

(For type and quantity of utilities/lubricants, see Chapter 12)

5 Transport and intermediate storage

5.1 General

Before shipment **sera** - products are checked for proper condition and functioning.

The customer has to check the product for transport damage immediately after receipt. Any damage detected is to be reported immediately to the responsible carrier and the supplier.

CAUTION !



The packaging material must be disposed of appropriately!

5.2 Transport

Select a hoist which is adapted to the weight of the pump and attach it to the motor flange of the pump

5.3 Storage

An undamaged packaging protects the unit during subsequent storage and should only be opened when the multi-layer diaphragm pump is installed.

Proper storage increases the service life of the multi-layer diaphragm pump and comprises prevention of negative influences such as heat, humidity, dust, chemicals etc.

The following storage instructions are to be observed:

- Storage place: cool, dry, dust-free and slightly ventilated
- Storage temperatures between +2°C and +40°C
- Relative air humidity not more than 50%.
- The maximum storage time for the standard system is 12 months.

If these values are exceeded, metal products should be sealed in foil and protected from condensation water with a suitable desiccant.

Do not store solvents, fuels, lubricants, chemicals, acids, disinfectants and similar in the storage room.

Operating instructions

6 Components of the multi-layer diaphragm pump

The multi-layer diaphragm pump may be assembled of the following (main) components:

- Stroke mechanism with drive
- Stroke length adjustment
- Built-in pump
- Pump body
- Valves

Optionales Zubehör:

- Actuator

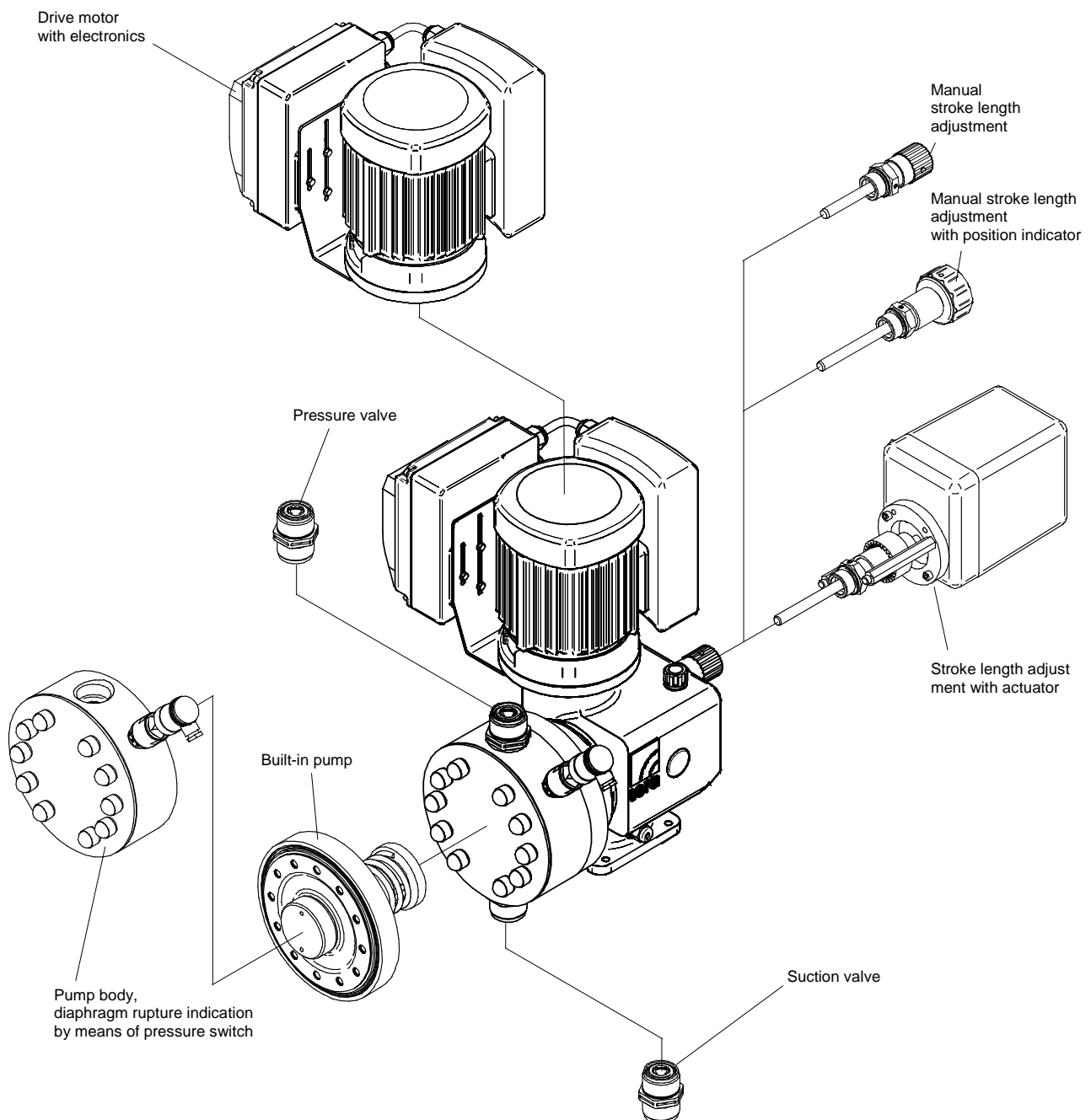

Fig. 06 Overview of the components

Operating instructions

7 Technical data

7.1 Dimensions

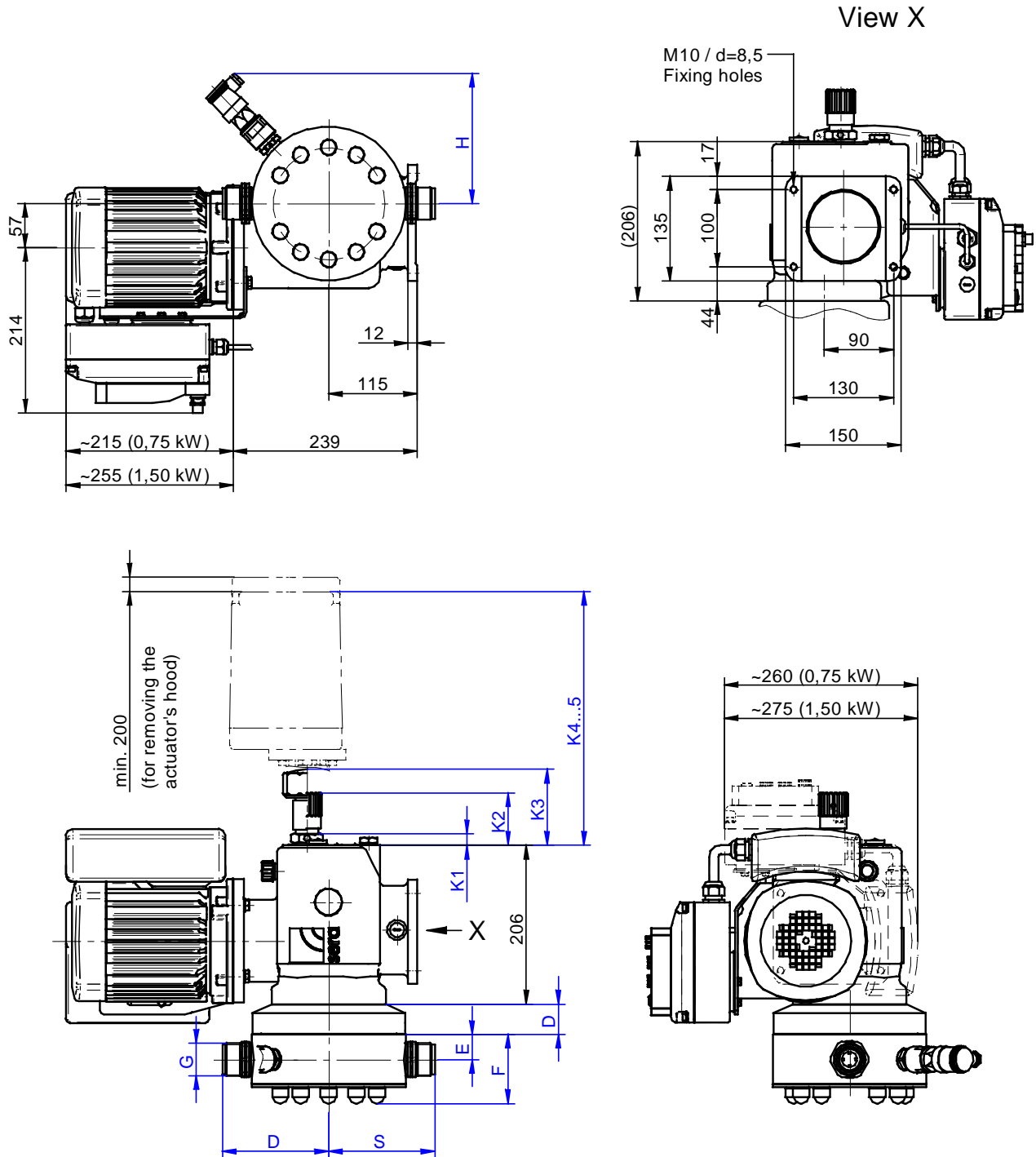

Fig. 07 Dimensions

Operating instructions

All dimensions in mm !

			Pump type					
			C 410.2 - 70 ML		C 410.2 - 135 ML		C 410.2 - 500 ML	
Valves	C	Connection thread	G ¾	G 1	G 1 ¼	G 1	G 1 ¼	G 1 ¼
	DN	Nominal width	8	15	20	15	20	20
	A	Single valves PVC	104	143	---	151	---	192
		Single valves 1.4571/1.4581	---	---	127	---	138	162
		Double valves PP-FRP, PVDF-FRP	94	---	127	---	138	162
		Double valves 1.4571/1.4581	95	---	---	---	---	---
	B	Single valves PVC	97	124	---	132	---	172
		Single valves 1.4571/1.4581	---	---	127	---	138	162
		Double valves PP-FRP, PVDF-FRP	94	---	127	---	138	162
		Double valves 1.4571/1.4581	95	---	---	---	---	---
	D	Built-in pump	59	58	39	43		
	Pump body (PK)	E	Centre of valve thread (1.4571)	21	33	33	34	
			Centre of valve thread (PP, PVC, PVDF)	27	33	33	37	
		F	PK, 1.4571 (without front plate)	54	80	80	84	
			PK, PP, PVC, PVDF (with front plate)	65	83	90	109	
		H	Pump body with pressure switch (1.4571)	148	161	171	186	
Pump body with pressure switch (PVC, PP, PVDF)			146	161	171	185		
Stroke length adjustment (SLA)	K₁	Blind flange for pump without SLA	14	14	14	14		
	K₂	Manual stroke length adjustment (max.)	79	79	79	100		
	K₃	Manual SLA with position indicator	110	110	110	115		
	K₄	Electric actuator	260	260	260	260		
	K₅	Electric actuator with PMR3	340	340	340	340		
Drive motor			see Fig. 07					
Stroke mechanism a. o. Dimensions for fastening of the pump								

Table 02 Dimensions

Operating instructions

7.2 Performance data

Type	Pump data							
	Nominal delivery rate ⁽²⁾ adjustable by stroke length adjustment	Maximum permissible pressure in the pump outlet	Minimum / maximum permissible pressure in the pump inlet	Maximum suction height ⁽¹⁾	Inlet/outlet nominal width	Nominal stroke frequency	Maximum stroke length	Motor size
	Q _N l/h	p ₂ max.	p ₁ min. / max.	WC	DN	min ⁻¹	h100	BG
	50/60 Hz	bar	bar	m	mm	50/60 Hz	mm	
C 410.2 – 70 ML	0-70	10 ⁽³⁾ 16	-0,3/0	3	15	97	8	80
C 410.2 – 135 ML	0-135	10 ⁽³⁾ 15	-0,3/0	3	15	97	10	80
C 410.2 – 500ML	0-500	10	-0,3/0	3	15	97	13	80
C 410.2 – 1200 ML	0-1200	5	-0,3/0	3	25	97	20	90

Table 03 Performance data

⁽¹⁾ Achievable height with media similar to water and filled suction line

⁽²⁾ Linear dosing range at a stroke length between 20% and 100%

⁽³⁾ Maximum pressure for pump bodies made of plastic

Motor data

Type	Motor data				
	Antriebsleistung	Frequency	Nominal voltage	Nominal current	Empfohlene Absicherung
	kW	Hz	V	A	
C 410.2 – 70 ML	0,75	50/60	3 ~ 380 - 420	2,0	C10A Sicherungs- automat
C 410.2 – 135 ML	0,75	50/60	3 ~ 380 - 420	2,0	
C 410.2 – 500 ML	0,75	50/60	3 ~ 380 - 420	2,0	
C 410.2 – 1200 ML	1,50	50/60	3 ~ 380 - 420	3,7	

Tab. 04 Motor data

Additional data of electronics

Type	Electrical data					
	Input voltage / Control input	Minimum time of contact signal / Minimum interval between pulses	apparent ohmic resistance for analogue input	Digital Output	Protection category	Thermal class
C 410.2-...	5...30 V DC	55 ms	100 Ω	PNP, internal supply max. 15V DC, 50 mA external supply max. 30V DC, 350 mA	IP 55	F

Tab. 05 Elektrische Daten

Operating instructions

8 Functional description

8.1 General

sera - multi-layer diaphragm pumps are run-dry safe oscillating displacement pumps that are characterised by high tightness of the dosing head. The liquid is conveyed by a deformable multi-layer diaphragm.

Multi-layer diaphragm pumps consist of the following (main) components:

- Drive motor
- Stroke mechanism
- Stroke length adjustment
- Built-in pump
- Pump body
- Suction and pressure valve

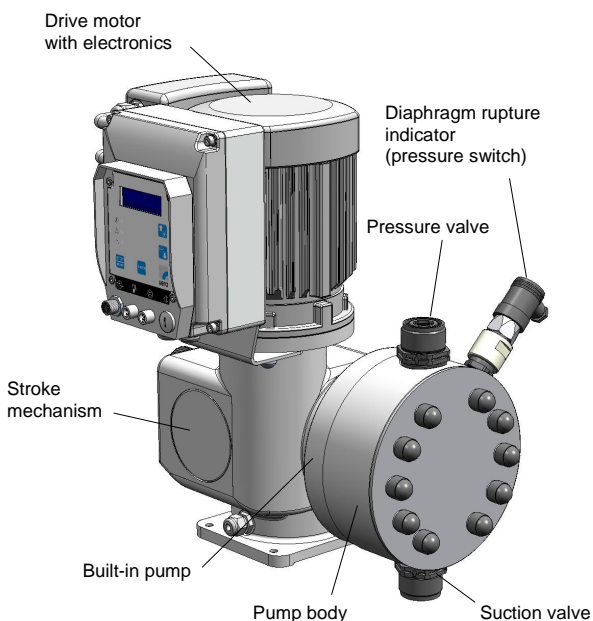

Fig. 08 Components

8.2 Components of the multi-layer diaphragm pump 410.2

8.2.1 Stroke mechanism

Function

Multi-layer diaphragm pumps of this type series use a rotary cam drive to transmit the rotation of the drive motor to the displacement body.

In case of the rotary cam drive, the eccentric provides the pressure stroke while the suction stroke is performed by a pressure spring (return spring).

The effective stroke length can be changed by means of an adjustable scale knob which prevents the connecting rod from following the rotary cam up to the rear dead-centre during suction stroke (see stroke length adjustment).

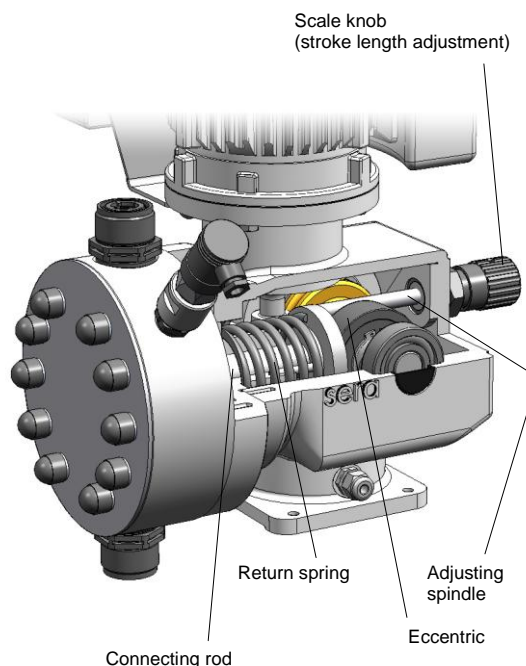

Fig. 09 Stroke mechanism

8.2.2 Electronics (operating panel)

The electronics permit proportional volumetric dosing via analogue signals 0/4 ... 20 mA or contact signals with the option of dividing or duplicating the pulse.

An integrated LCD display and three LED's for warning and fault display indicate the current status of the dosing pump (see Fig. 10).

A connection for flow monitoring or flow measurement as well as an empty signal with pre-alarm and dry operation alarm are installed as standard (see Chapter 10.3.2)

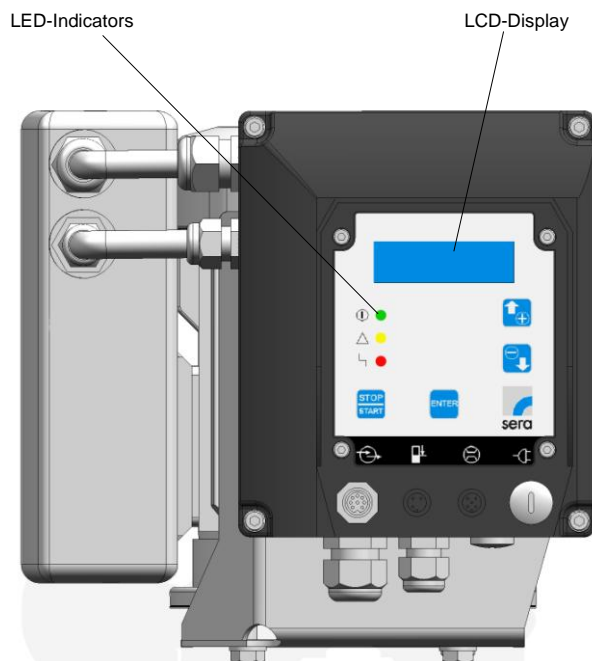

Fig. 10 Electronics

Operating instructions

8.2.3 Stroke length adjustment

General

The delivery rate of the pump is regulated by changing the stroke length. The stroke length is infinitely variable between 20% and 100%.

Stroke length below 20% results in display „OUT OFF RANGE CALIBRATE!“

A linear dosing behaviour is achieved with stroke length adjustments between 20% and 100%.

8.2.3.1 Manual stroke length adjustment (standard)

The effective stroke length of the connecting rod is changed by turning the scale knob.

The stroke length can be adjusted both during operation and at standstill of the pump (system not under pressure).

The set stroke length can be read off a scale, e.g. 75% (see Fig. 11).

With the 20-steps adjustment on the scale knob, the stroke length can be set individually with a tolerance of 0.5%.

Turning counterclockwise → the effective stroke length is increased, the delivery rate increases.
(see Fig. 11)

Turning clockwise → the effective stroke length is reduced, the delivery rate reduces.

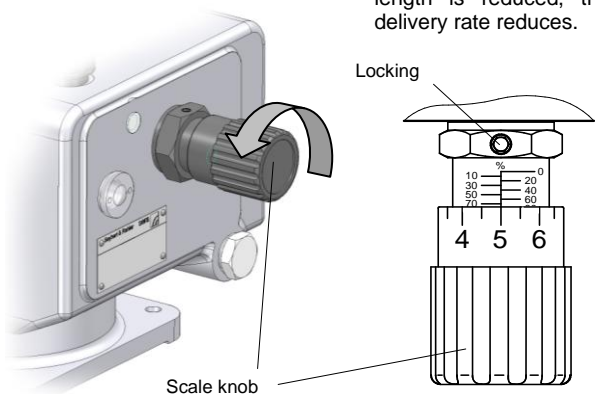

Fig. 11 Stroke length adjustment / Scale knob

8.2.3.2 Manual stroke length adjustment by means of percent scale (option)

The stroke length is adjusted by turning the hand wheel. The stroke length can be adjusted both during operation and at standstill of the pump (not under pressure).

Turning counterclockwise → the effective stroke length is increased, the delivery rate increases.
(see Fig. 12)

Turning clockwise → the effective stroke length is reduced, the delivery rate reduces.

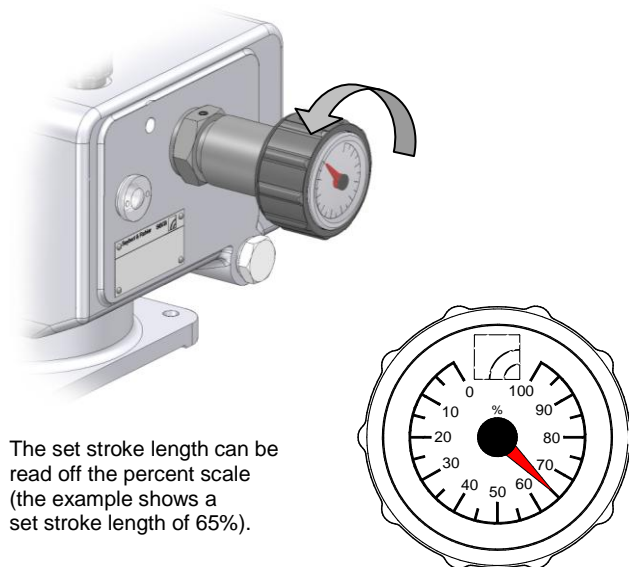

The set stroke length can be read off the percent scale (the example shows a set stroke length of 65%).

Fig. 12 Stroke length adjustment with position indicator

In delivery state, the stroke length adjustment is factory set to 50%.

CAUTION !



The percent scale may get misadjusted during transport. If the pointer does not match the 50%-setting the percent scale is to be readjusted with the pump running!

CAUTION !



The locking (see Fig. 11 and 13) is to be released (using a spanner SW3) before the stroke length is changed. Then the locking must be tightened again. This ensures that the set stroke length does not change during operation.

Operating instructions

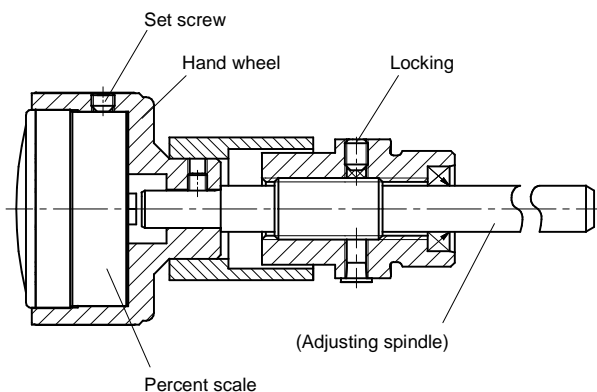

Fig. 13 Stroke length adjustment with position indicator

Adjusting the percent scale:

- Switch the multi-layer diaphragm pump on
- Loosen set screw
- Remove percent scale from the hand wheel
- Manually turn the percent scale to 0% setting
- Use hand wheel to set the stroke length to 0%. Turn hand wheel clockwise until there is no further stroke movement (connecting rod does no longer hit the adjusting spindle)
- Insert percent scale again
- Use set screw to secure the percent scale to the hand wheel
- Adjust desired stroke length

8.2.3.3 Automatic stroke length adjustment by means of an electric actuator

The electric actuator is directly mounted to the stroke mechanism of the dosing pump. A clutch transmits the rotary motion of the actuator drive shaft to the adjusting spindle. The axial displacement is compensated in the clutch.

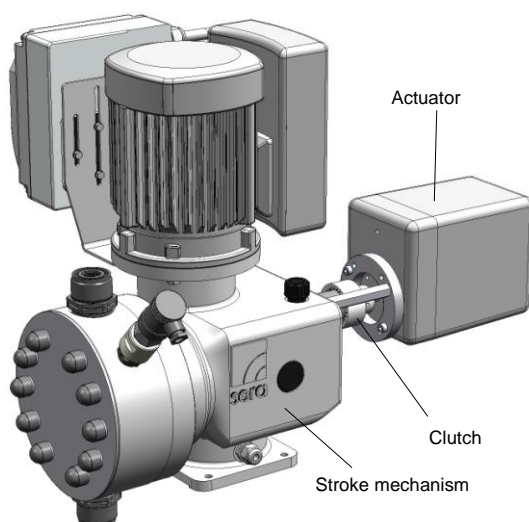

Fig. 14 Stroke length adjustment by means of electric actuator

In case of dosing pumps with electric actuator, the stroke length can no longer be adjusted manually on the pump. (Exception: actuator with hand wheel)

The actuator is equipped with two integrated limit switches as standard as well as with a position potentiometer for position feedback.

Both limit switches are factory set so that the drive switches off at a stroke length of 0% and 100%, even if a control voltage is applied.

This guarantees that adjustments can only be made within the permissible range. The position potentiometer is driven by a safety clutch which prevents damage caused by incorrectly adjusted limit switches.

Activation is performed by appropriate control units (see **sera** – accessories).

The set stroke length can be read off on the pump (percent scale).

Information on the electrical connection is given inside the cover of the actuator.

CAUTION !



The adjustment is only possible when the pump is running!

8.2.3.4 Automatic stroke length adjustment by means of an electric actuator with integrated positioner (PMR3)

same as Chapter 8.2.3.3, in addition:

- PMR3 positioner

This PMR3 positioner which is integrated in the actuator enables an actuator setting from 0...100% that is proportional to the connected input signal.

As an option, the actuator can also be provided with a collective fault signal.

Information on the electrical connection is given inside the cover of the actuator.

Operating instructions

8.2.4 Built-in pump

General

Function

The diaphragm consists of three layers and is linked with the connecting rod. Only the front layer, the so-called working diaphragm, comes in direct contact with the pumped medium.

The middle layer functions as a signal diaphragm. In case of rupture of the working diaphragm, the medium is fed to the diaphragm rupture signalling device in a controlled manner.

The third membrane functions as protective diaphragm and ensures that no pumped medium will leak out, even in case of a diaphragm rupture.

A diaphragm rupture is indicated by a pressure switch (electrical).

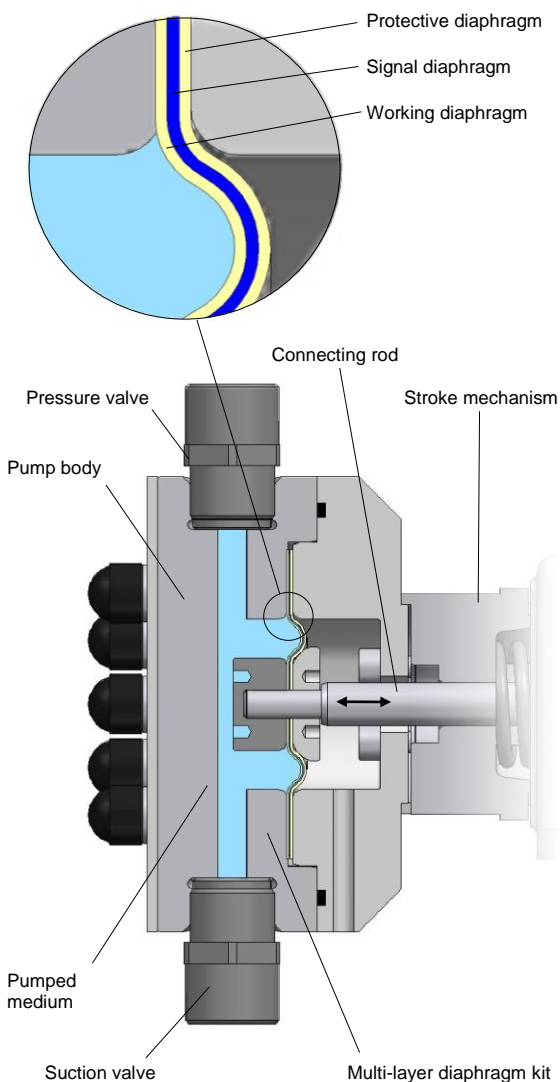

Fig. 15 Functional principle of the multi-layer diaphragm pump

8.2.4.1 Multi-layer Diaphragm

The multi-layer diaphragm consists of a package of a total of three individual diaphragms.

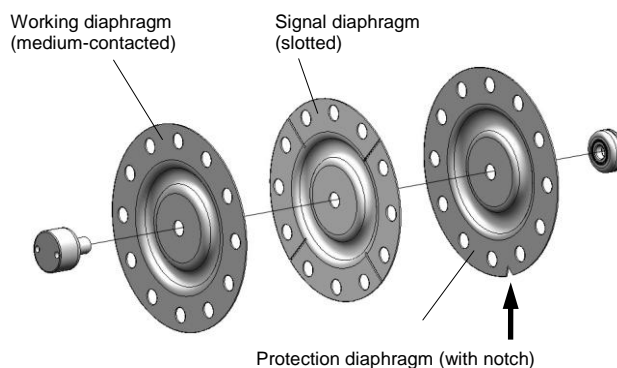

Fig. 16 Assembly of multi-layer diaphragm

The notch of the protection diaphragm indicates the correct mounting position changing the diaphragm set (see Chapter 12.4)

8.2.5 Pump body

Depending on the applied backpressure, movements of the plastic pump body in elastic materials are possible. This does not affect the pumps's service life or operational reliability.

Operating instructions

8.2.6 Suction/pressure valve

The pump valves are always ball valves which can only function properly when they are installed in a vertical position. The condition of the valves is decisive for the operational behaviour of the pump. The valves should only be exchanged completely. Pay attention to the flow direction when installing the valves (see Fig. 17).

CAUTION !

Pressure valve above, suction valve below!



Flow direction

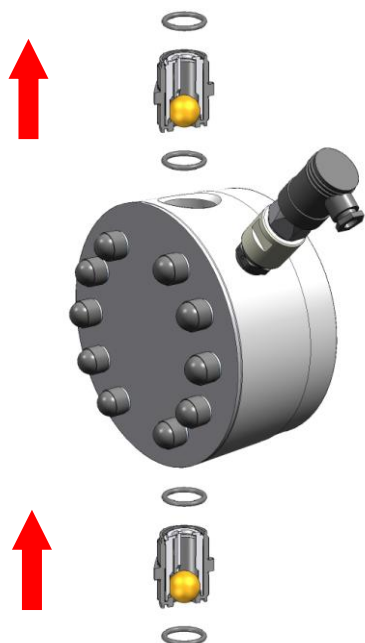



Fig. 17 Double valves, GFK design

8.2.7 Diaphragm rupture monitoring (with pressure switch)

sera - multi-layer diaphragm pumps of the 410.2 ML series are equipped with a diaphragm rupture monitoring device.

CAUTION!

For more detailed information about the indicators of the diaphragm rupture monitoring, please see Chap. 18!



Bei einem Bruch der Arbeitsmembrane baut sich am Druckschalter ein Druck auf. Das anstehende Signal muss ausgewertet und so weiter verarbeitet werden, dass die Pumpe sofort abgeschaltet wird.

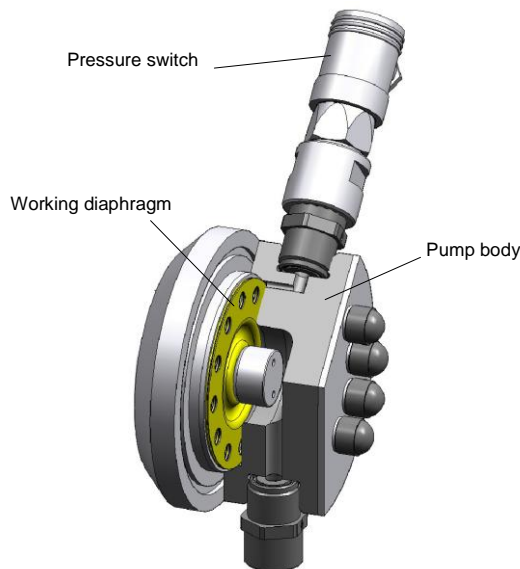

Fig. 18 Diaphragm rupture signalling with pressure switch

8.3 Drive motor

A sera – diaphragm pump of series C 410.2 ML is driven by a threephase-motor controlled by the electronics.

8.3.1 Start-up

Preconditions:

Make sure that voltage and frequency correspond with the specifications on the type plate of the electronics.

The nominal motor power refers to an ambient temperature of maximum 40°C and an installation site below 1000m above sea level. Motor output will be reduced if these values are exceeded (see VDE 0530).

Suitable for "moderate" group of climates according to IEC 721-2-1.

CAUTION !

The drive motor will heat by operation of the pump. Do not touch the motor during operation!



8.3.2 Motor protection

A protective motor switch is not necessary due to the fact that a thermic overload protection is integrated in the pump for the protection of the motor.

Operating instructions

8.3.3 Maintenance of the drive motor

The electric motor must always be kept clean so that neither dust, dirt, oil nor other contaminants may affect the correct operation.

In addition, we recommend to ensure that:

- the motor does not produce strong vibrations
- suction and blowing openings for the supply of cooling air are not closed or restricted (may lead to unnecessary high temperatures in the windings).

The ball bearings inserted in the motor are lubricated for life.

8.3.4 Restart

Restart the system as described in Chapter 8.3.1 after maintenance work of after longer periods of standstill.

9 Assembly / Installation

9.1 Installation instructions

- The standard model of the pump is only approved for installation in dry rooms in a non-aggressive atmosphere, at temperatures between +2°C and +40°C, permitted humidity until approx. 90%, altitude 1000 m above sea level
- For dimensions of the pump connections and fixing holes, see Fig. 07, Table 02
- Install the pump in such a way that there is no vibration and no tension and that it is aligned precisely.

CAUTION !



When the C 410.2 is installed next to a pump of series 204.1 and C/CS 409.2 a minimum distance of 100 mm between the pumps (motor housings) has to be kept!

- Install the pump at the optimum possible operating height. Mount the pump in such a way that the valves are vertical.
- Ensure that there is sufficient space around the pump body and the suction- and pressure valve so that these parts may be easily dismantled, if required.
- The stroke length adjustment, indicator scale and visual diaphragm rupture signalling device must be easily accessible and readable.
- Design the nominal diameters of the downstream pipes and of the connections built into the system to be the same size or larger than the nominal inlet and outlet diameters of the pump.
- To check the pressure ratios in the pipe system, we recommend to provide for connections for pressure gauges (e.g. manometers) near the suction and pressure nozzles.
- Drain cocks are to be provided.
- Prior to connecting the pipes, remove the plastic caps on the suction and pressure nozzles of the pump.
- Check that the fixing screws for the pump body are tightly fitted and, if necessary, retighten.

CAUTION !



The pump is designed for operation in non-hazardous areas!

Tightening torques of the fixing screws

Pump type	Pump body without front plate	Pump body with front plate
C 410.2 – 70 ML	15 Nm	15 Nm
C 410.2 – 135 ML		
C 410.2 – 500 ML	20 Nm	20 Nm
C 410.2 – 1200 ML		

Table 06 Tightening torques

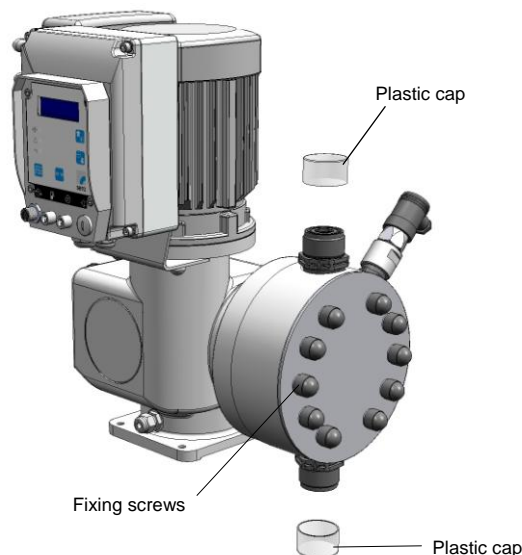

Fig. 19 Multi-layer diaphragm pump with plastic caps

- If the pump is equipped with an actuator provide for sufficient space to remove the cover (please see Chapter 7.1 "Dimensions").
- Connect pipes to the pump in such a way that there are no forces acting on the pump, such as e.g. misalignment, weight or stress of the pipe.
- Keep the suction lines as short as possible.
- Use pressure- and medium-resistant hoses / pipes.
- All pipes and containers connected to the pump must comply with the regulations and must be cleaned, tension-free and intact.

CAUTION !



If toxic, crystallizing or corrosive liquids are conveyed the pipe system is to be equipped with facilities for emptying, cleaning and rinsing with an appropriate medium, if necessary.

Operating instructions

CAUTION !



Mount the multi-layer diaphragm pump in such a way that leaking medium cannot cause any damage.

In order to avoid cavitation, overloading and excessive delivery, the following points should be noted:

- avoid high suction heights
- keep pipes as short as possible
- choose sufficiently large nominal diameters
- avoid unnecessary choke points
- install a pulsation damper
- install a pressure relief
- install a pressure keeping valve, if necessary
- in the case of degassing media, provide for a supply

CAUTION !



The operator must provide for appropriate protective measures (collecting basin, diaphragm rupture signalling device) in the supply pipe so that the container does not drain off in case of a diaphragm rupture.

9.1.1 Provide overpressure protection

if the permissible pressure in the pump head may be exceeded, e.g. when a shut-off valve is closed or if the line is blocked:

- install an overflow valve

When using an external overflow valve, please note for the return line:

- lead the overflow line with descending gradient in the storage tank which is under atmospheric pressure or in an open drain gutter (see Fig. 20)
- or connect the overflow line directly to the pump suction line, but only if there is no check valve inside the suction line (e.g. foot valve of a suction lance) (see Fig. 21).

CAUTION !



Shut-off valves must not be closed when the pump is running!

CAUTION !



Provide an overpressure protection (e.g. overflow valve) if the permissible operating pressure may be exceeded.

CAUTION !



If the permissible operating pressure is exceeded and the pump is not equipped with an overpressure protection the pump may be damaged.

CAUTION !



The pumped medium may spout out if the pump is damaged.

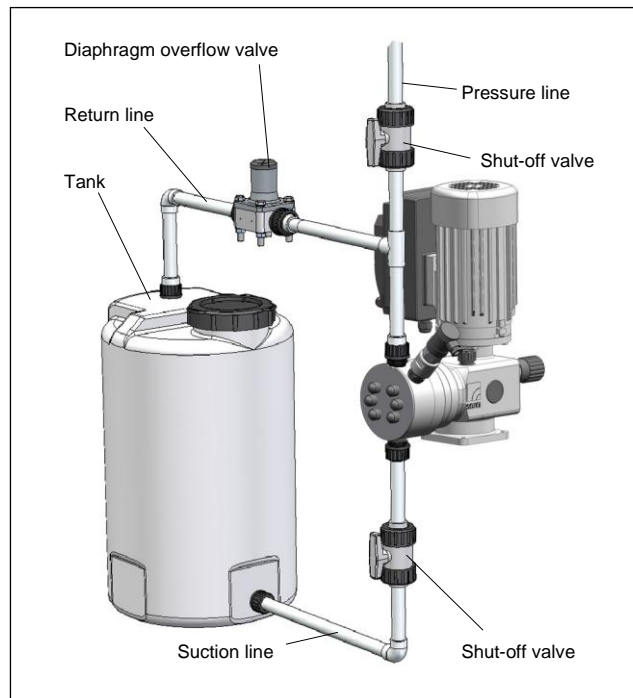

Fig. 20 System with (external) overflow valve

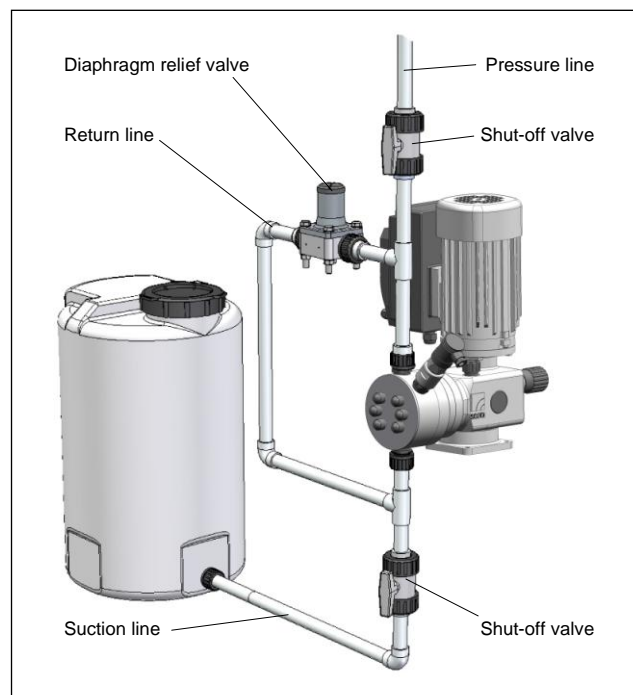

Fig. 21 System with (external) overflow valve

Operating instructions

9.1.2 Prevent a backflow of the pumped medium

if the dosing line is linked with a main pipe:

- install an injection fitting (dosing valve).

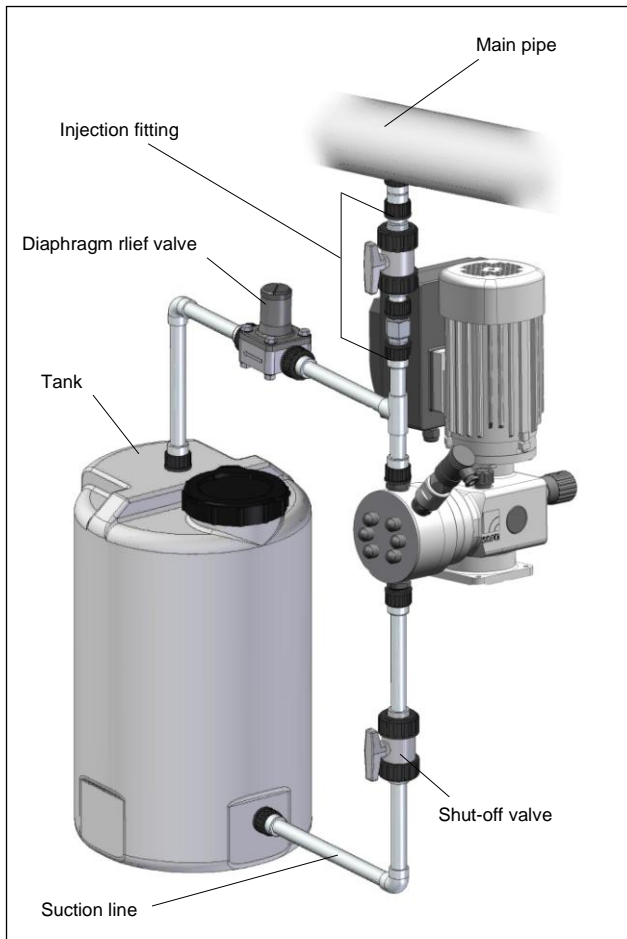



Fig. 22 Installing an injection fitting

CAUTION ! 
The contents in the dosing line is mixed unintentionally if a backflow from the main pipe is not prevented.

CAUTION ! 
Note / avoid chemical reactions during a backflow.

9.1.3 Eliminate undesired siphoning

when dosing in a main pipe with negative pressure:

- install a pressure keeping valve in the dosing line.

CAUTION ! 
When installing the pump it is to be ensured that an excess supply (due to a positive pressure difference (≥ 1 bar) between pressure and suction side) is avoided.

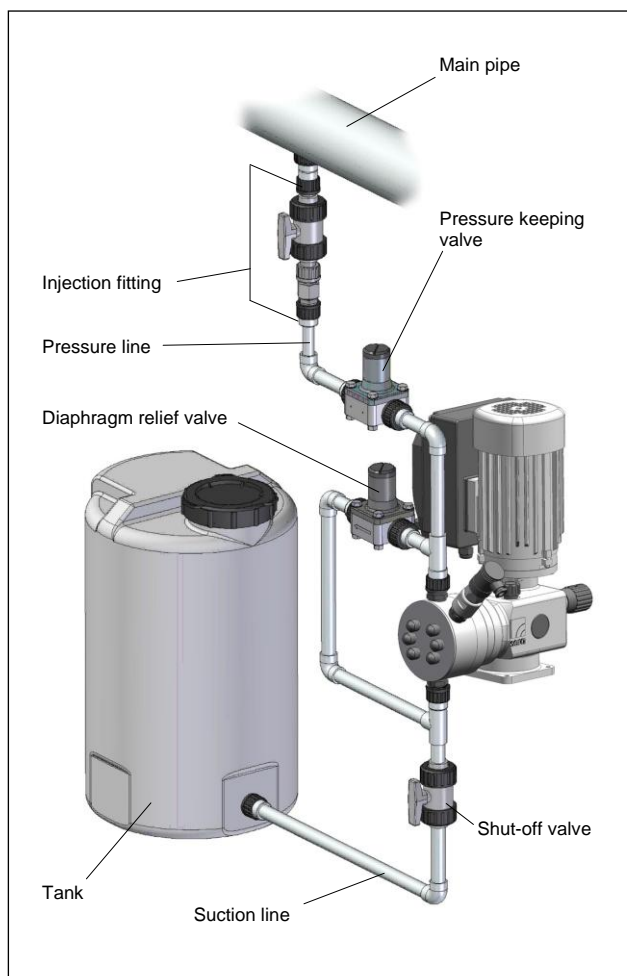



Fig. 23 Installing a pressure keeping valve

Operating instructions

9.1.4 How to ensure an air-free suction

if, due to a falling fluid level in the tank, air may be drawn in and delivered to a pressurised line or against a pressure keeping valve:

- install a vent valve in the pressure line.

CAUTION ! 

The delivery flow may be interrupted if air remains in the suction line!

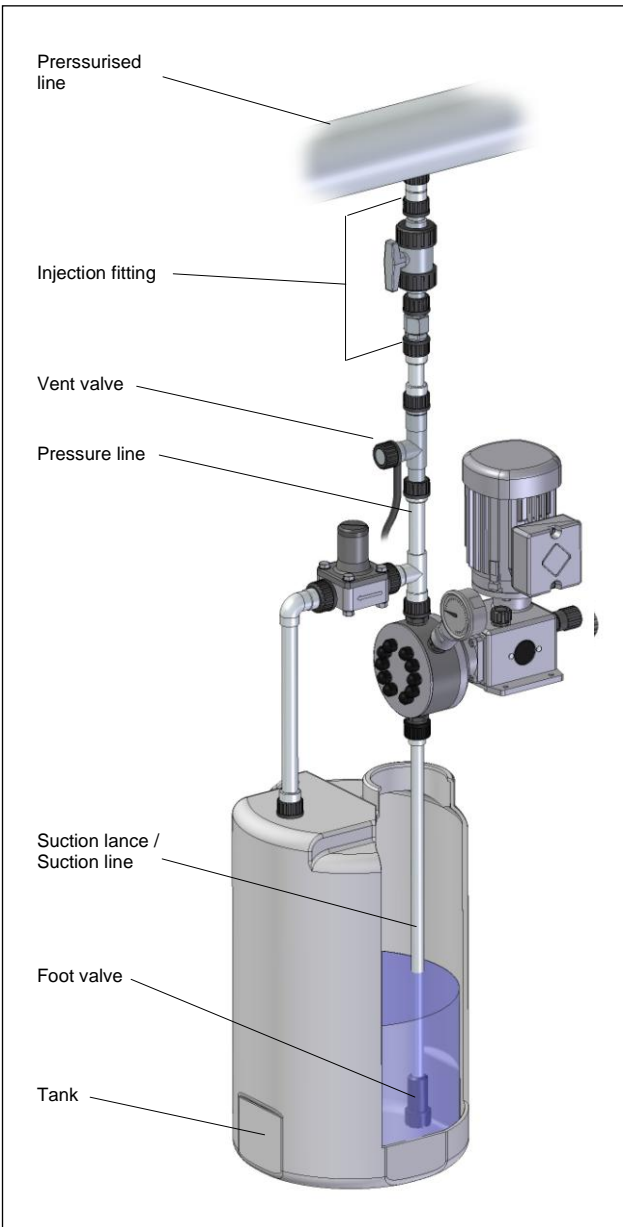

Fig. 24 Installing a vent valve

9.1.5 Install the empty-tank alarm

so that the tank is refilled before air is drawn in.

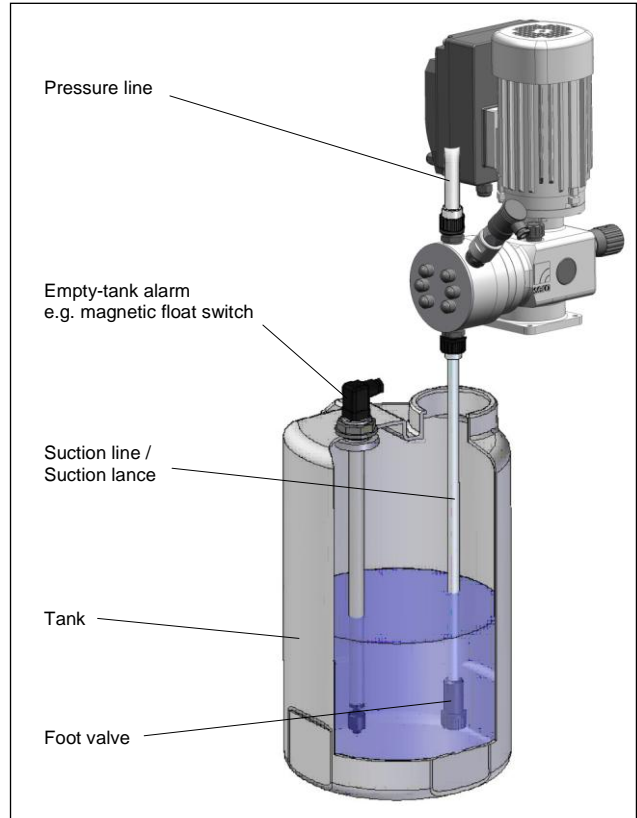



Fig. 25 Installing an empty-tank alarm

CAUTION ! 

The delivery flow may be interrupted if air remains in the suction line!

Operating instructions

9.1.6 How to avoid draining of the suction line

- Install a foot valve at the end of the suction line

Based on calculations, the dimension 'H' may not exceed the number that is equal to the specified maximum suction height of the pump divided by the density of the pumped medium and in consideration of mass acceleration and viscosity of the medium.

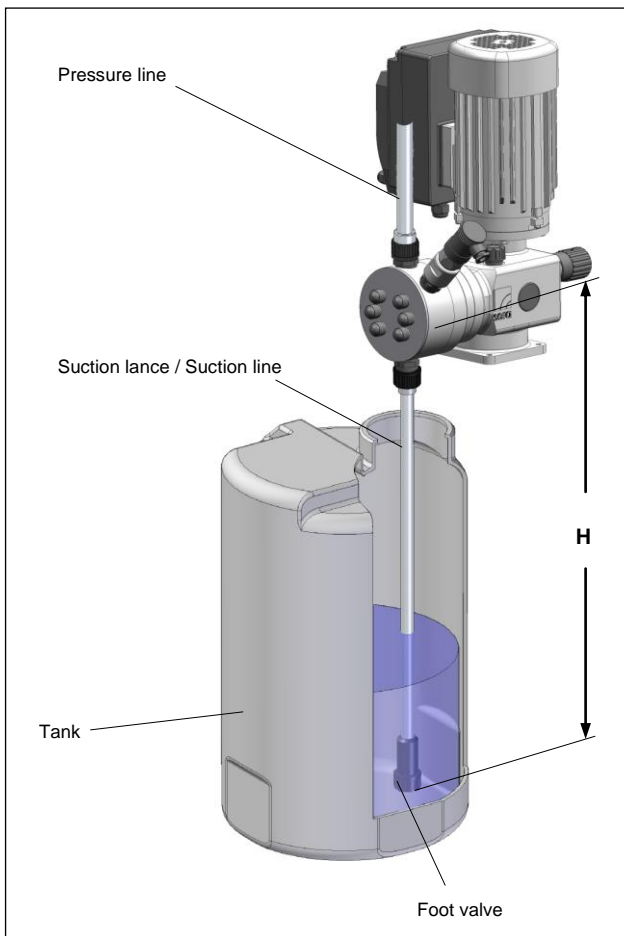

Fig. 26 Avoid draining of the suction line

9.1.7 Line strainer

- Connect suction line slightly above the bottom of the tank and install a line strainer (0.1 – 0.5mm aperture size – depending on nominal width of the valve).

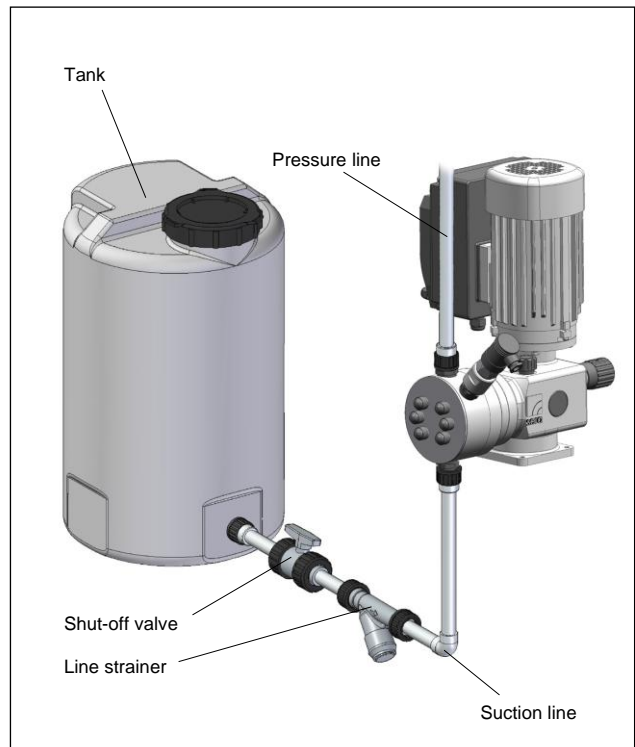

Fig. 27 Installing a line strainer

CAUTION !

If contaminations are not removed this may result in malfunctions of the pump and the system.



Operating instructions

9.1.8 Suction via a siphon pipe

for use with high tanks without connection at the tank bottom:

- install a siphon tank.
- Pay attention to acceleration pressures which may be generated in a long suction line.

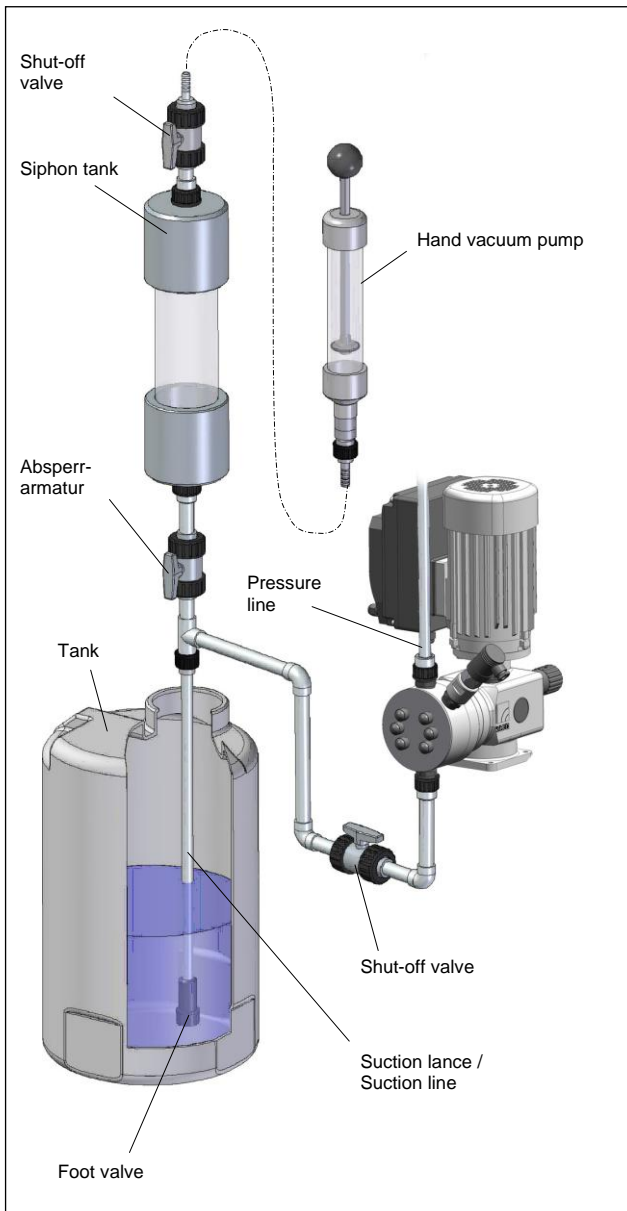

Fig. 28 Installing a siphon tank (sera - fitting)

9.1.9 In case of easily degassing pumped media

- Install the pump so that it can be operated with afflux..

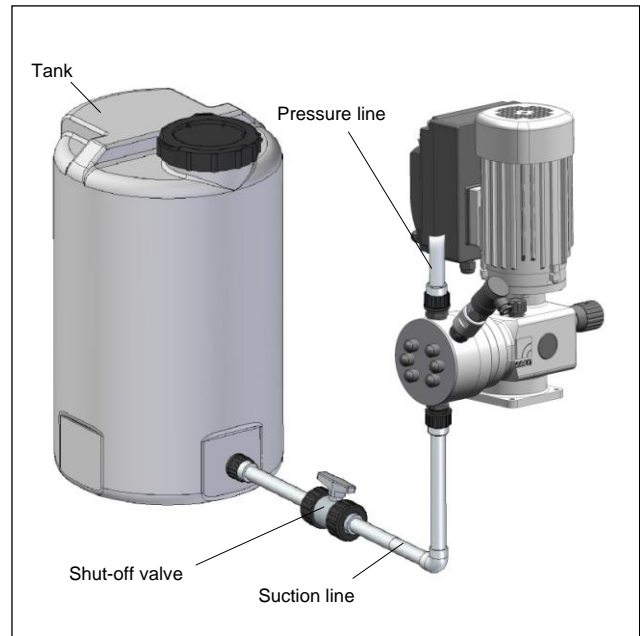

Fig. 29 Installation with supply line

9.1.10 Damping of the pulsation

by installing pulsation dampers if:

for procedural reasons, a pulsation-poor delivery rate is desired.

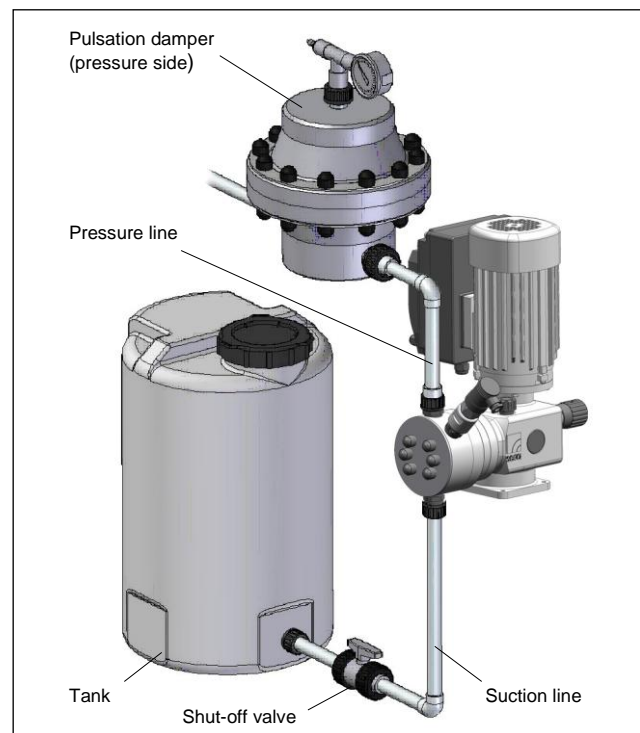

Fig. 30 Installing a pulsation damper (I)

Operating instructions

Acceleration forces which arise due to the pipe geometry must be reduced.

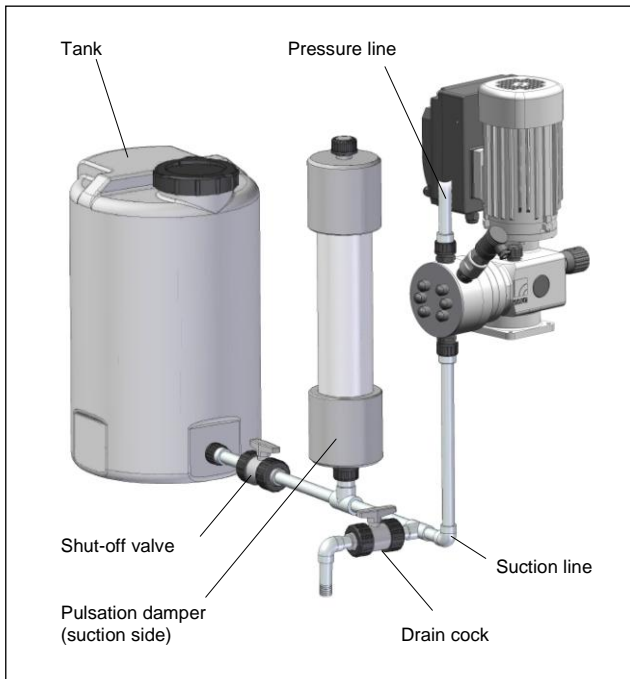

Fig. 31 Installing a pulsation damper (II)

CAUTION !



Undamped acceleration forces may lead to the following faults / damage:

- delivery rate fluctuations
- dosing errors
- pressure surges
- valve wobbles
- increased wear on the suction- and pressure side of the pump;

mechanical damage of the pump
leakage and valve wobbles if the permissible maximum pressure on the pump pressure side is exceeded.

Installation of suction- and/or pressure pulsation damper near the pump head.

If both pulsation damper and pressure keeping valve should be integrated install the pressure keeping valve between pump and pulsation damper.

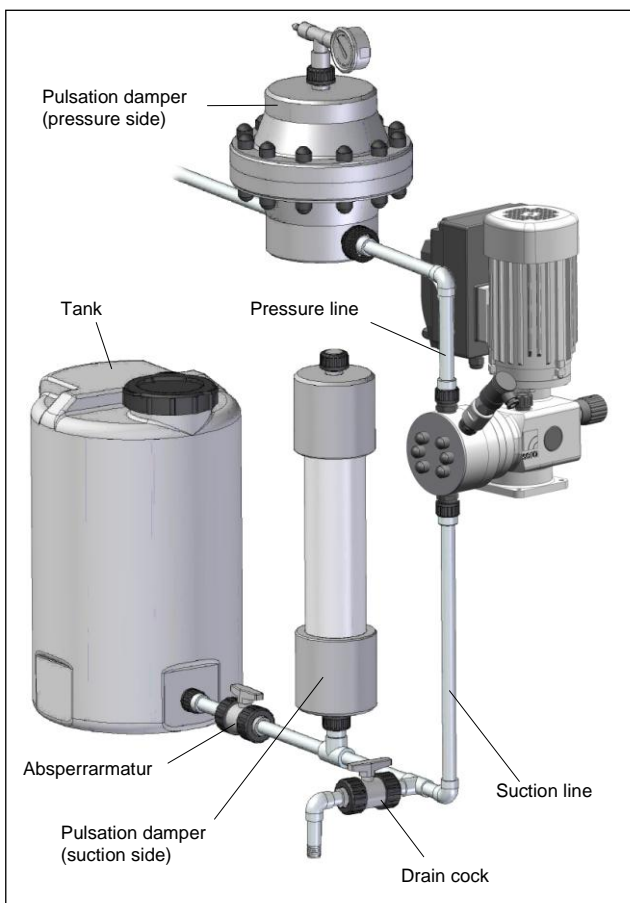

Fig. 32 Installing a pulsation damper (III)



Fig. 33 Installing a pulsation damper and a pressure keeping valve

Operating instructions

10 Electric connections

10.1 Mains connections

CAUTION !



Avoid short switch off and restart of the dosing pump!

The **sera** – diaphragm pump is delivered ready for connection with a 2m mains cable and a CEE-socket/ 16A 5-poles 6h. The diaphragm pump is designed for an operating voltage range of 380 – 420 V, 50/60 Hz.

CAUTION !



The pump restarts in the selected operating mode after the power supply was switched on or a power supply recovery following a mains failure!

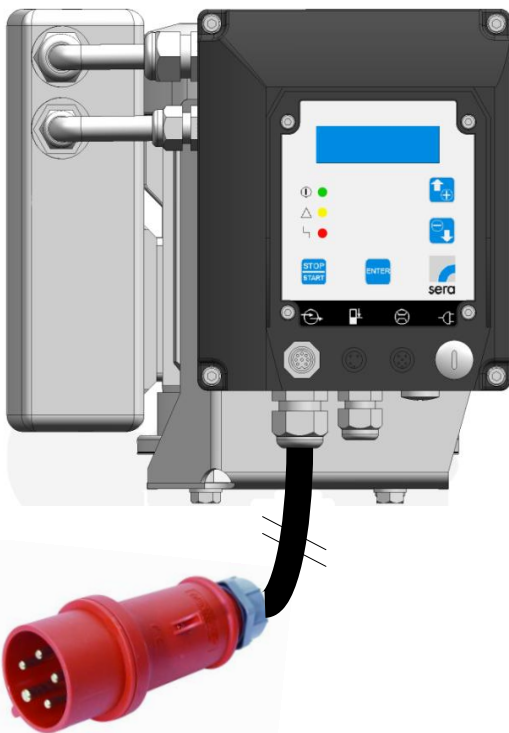

Fig. 34

The mains connection requires 3~ 400V + neutral conductor + protective conductor.

The leakage current against earth amounts to approx. 7 mA.

Recommended protection: 3-poles automatic fuse C10A

CAUTION !

Only operate the pump when it is connected to an earthed power supply!

10.2 Connection mains pipe

CAUTION !



Activities of any kind should only be carried out by qualified employees.

CAUTION !



After the partition of the mains you have to wait at least 4 minutes before carry out work at the pump again.

Open the electronic housing

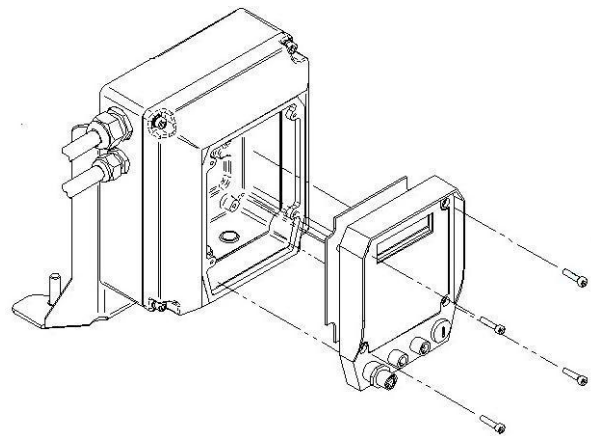

Fig. 35 Opening of electronic housing

Disengage the four hexagon socket screw keys for 3mm and pull the electronic forward carefully to get access to the mains connections on the reverse side.

Tip the electronic softly forward but pay attention that meanwhile no other connections will be damaged or pulled out.

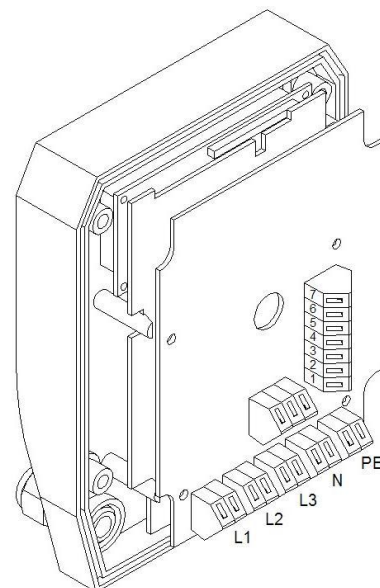

Fig. 36 Rear view of the electronic

Operating instructions

Insert the mains pipe through the cable fitting M20 from below into the housing.

Core strip length: of 5 -6 mm
Cross section: of 1 -2,5 mm²

For the connection to the cage clamp a screw driver with 3,5 x 0,5mm is required.

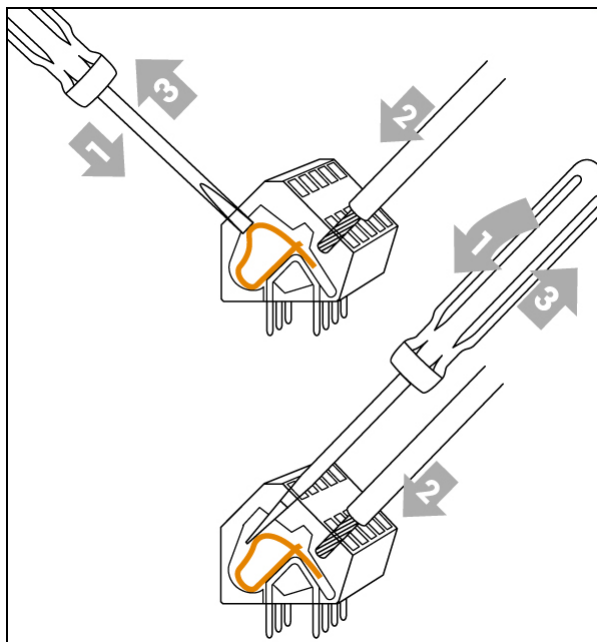

Fig. 37 Connection engineering: WAGO CAGE CLAMP®
Handling step 1-3

Connect the three mains phases with the clamps L1, L2, L3.
Connect the neutral conductor in N and the protective earth to PE.
Afterwards fix the electronic back on the housing.

The direction of rotation of the drive can not be changed by changing the phases.
The direction of rotation of the drive is preset to anticlockwise rotation ex works.

10.3 Electrical interfaces

The connectors for the electrical interfaces are located on the back of the pump below the control panel.

10.3.1 Control inputs and outputs

The pump is equipped with three control inputs and two control outputs. They can be programmed with different functions. All three inputs can be used as digital inputs, whereas two of them can optionally be configured as analog inputs (inputs 02 and 03, see Chapter 11.8.2). When leaving the factory, the inputs and outputs are preset as described in Tab. 07.

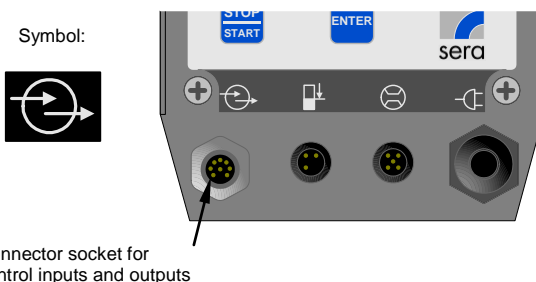

Fig. 38 Connection of control inputs and outputs

Operating instructions

Standard delivery of the dosing pump includes a 5m control cable, which is to be connected to the 8-pin socket of the control inputs and outputs. Tab. 07 shows the identification of the individual leads of the control cable.

Lead colour	Pin	Function (ex works setting)
WH (white)	1	Eingang 01 (Impuls)
BN (brown)	2	Eingang 02 (Analog 01)
GN (green)	3	Eingang 03 (Extern EIN)
YE (yellow)	4	Ausgang + / Signal + / 15 V DC
GY (grey)	5	Ausgang 01 (Sammelstörung)
PK (pink)	6	Ausgang 02 (Hubsignal)
RD (red)	7	Masse
BU (blue)	8	Masse

Table. 07 (Identification of the leads of the control cable)

The digital inputs can not only be switched by a potential-free contact signal but also **directly via a control voltage signal** (e.g. 24V DC). This enables, for example, the direct connection of a programmable logic controller to the dosing pump.

CAUTION !



When an external supply (for example, 24 V DC) is connected to the pin output + (colour of cable lead: yellow) the following has to be considered:
A protective diode is necessary in the feeding pipe of the external supply in order to exclude a feeding back of the pump. (see fig. 39).
Connect the anode with 24V DC.
Connect the cathode with the yellow lead of a cable.
Use the diode type 1N4007 or the like.

Fig. 39 shows exemplarily the control of the digital inputs 01 and 03 via a potential-free contact signal.

CAUTION !



The outputs 01 and 02 are not potential-free! In order to enable a potential-free switching via the outputs, the use of a relay is necessary.

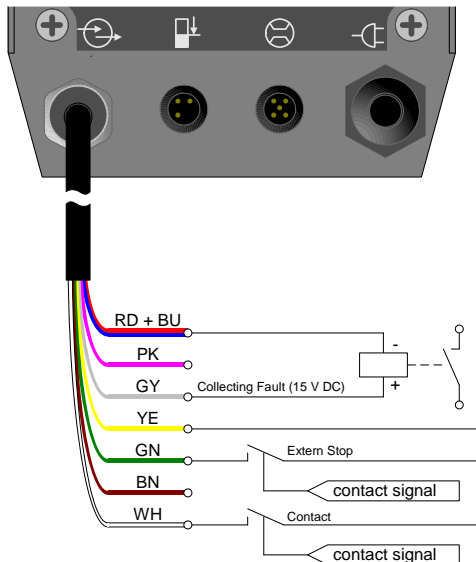

Fig. 39 Control of digital inputs via a potential-free contact signal

CAUTION !



The maximum voltage/maximum current withstand capability of the control inputs and outputs is as follows:

Inputs: 30V DC / 50mA
Outputs: 15V DC / 50mA (internal supply)
30V DC / 350mA (external supply)

CAUTION !



The output + / signal + connection pin (lead colour: yellow) is **not short-circuit proof!** In case of a short-circuit, the control electronics may get damaged! Therefore, please make absolutely sure that the signal + connection pin is not directly connected with the earth connections (lead colour: red and blue)!

Fig. 40 shows exemplarily the direct activation of the digital inputs 01 and 03 via a control voltage signal (in this example: 24V DC) of a programmable logic controller.

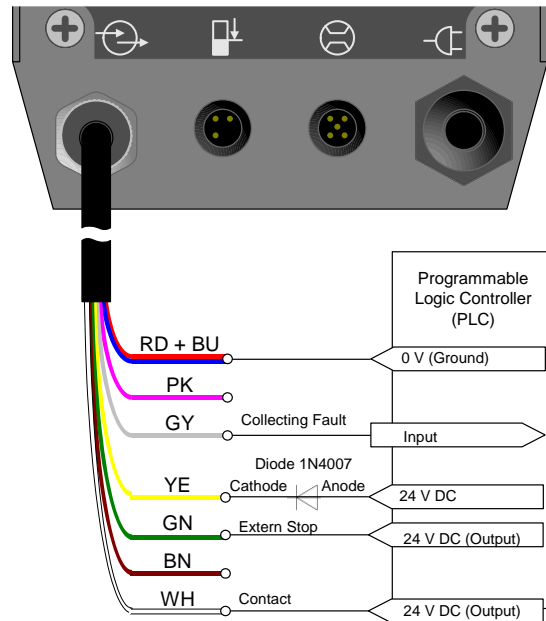



Fig. 40 Direct activation of digital inputs via a control voltage signal of a programmable logic controller

Operating instructions

10.3.2 Level input with pre-alarm and dry run

NOTE ! 

Pre-alarm and dry run are connected to the same jack. When leaving the factory, both inputs are preset to “closing when floating down”. However, if necessary, they can be freely configured

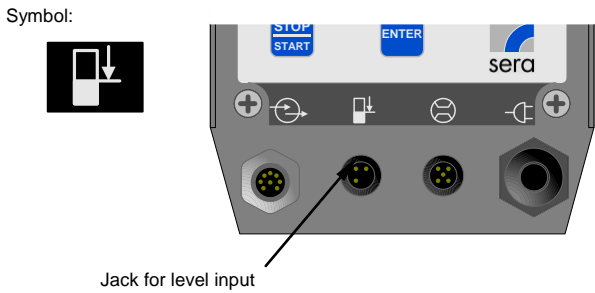



Fig. 41 Connection for leader contact / main contact

Pin	Description	Color of wire Standard cable
1	Pre-alarm	brown
3	Ground	blue
4	Dry run	black

Table 08 Pins

10.3.3 Input for flow control and flow meter

CAUTION ! 

Only flow controllers and flow meters made by sera may be connected to the dosing pump. If you use other than sera products, the electronics might get damaged.

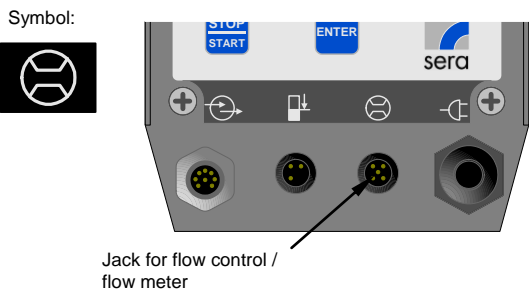

Fig. 42 Connection for flow control / flow meter

sera - flow controllers and flow meters are delivered completely with cable and plug. Electrical connection is made directly to the 5-pin socket.

11 Operation

11.1 Operating elements

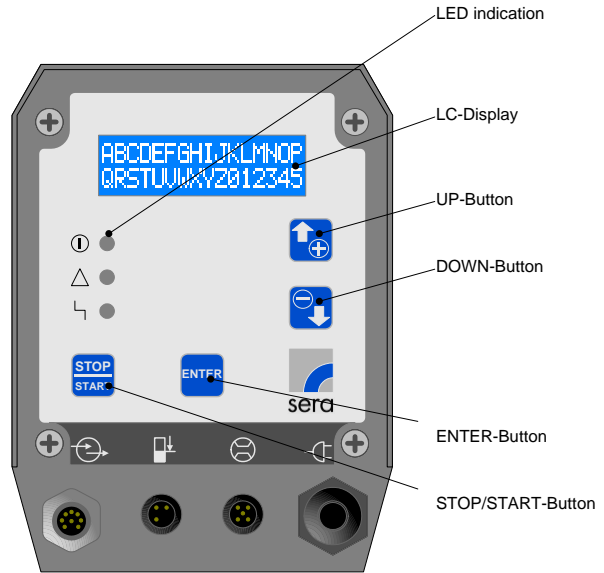

Fig. 43 Electronics control panel

11.2 LED operation indicators

Three light-emitting diodes (LED) indicate the status of the pump.

Green: Operation and stroke indicator



When switching on the pump, the green LED lights steadily. The operation indicator works in combination with a stroke indicator; during pump operation, the LED flashes in accordance with the current stroke frequency.

Yellow: Warning indicator



The yellow LED indicates all occurring warning messages (see Tab. 09). The warning is not only indicated by the LED but also as plain text in the LCD display.

Red: Fault indicator



The red LED indicates all occurring faults (see Tab. 09). The fault is not only indicated by the LED but also as plain text in the LCD display.

Operating instructions

	Green LED	Yellow LED	Red LED
Ready	On		
Stroke confirmation	Flashes		
Internal error			On
Supply voltage too low / too high		On	
No mains			
Level monitoring:			
Level pre-alarm		On	
Dry run			On
Dosing control (flow controller or flow meter):			
No flow - with warning message		On	
No flow - with shut-off			On
Flow too low - with warning message		On	
Flow too low - with shut-off			On
Optional diaphragm rupture monitoring:			
Diaphragm rupture			On
Vent valve (CS 409.2):			
Venting	Flashes		On
Analog mode:			
mA signal < 3.5mA			On
mA signal > 20.5mA			On

Table 09 Overview of LED indicators

NOTE !



The “dry run” fault message suppresses the “pre-alarm” warning. This means that if the pump runs dry while the 2-stage level monitoring is activated, then only the red LED will flash.

11.3 Key operation

Operation of the pump is performed with 4 keys:



STOP/START key

After connection to the power supply, the pump is switched ON/OFF using the STOP/START key.



ENTER key

You can use the ENTER key to open and confirm value input fields and to select menu items.



UP / DOWN key

Using the UP/DOWN key, you can scroll the different menu items / menu levels and select the display of various operating messages.

During parameter adjustment, the UP key is used to increase the parameter value and the DOWN key is used to decrease the parameter value.

Operating instructions

11.4 Parameter table

Tab. 10 shows the factory settings of the controllable diaphragm pump. With these defaults, the user can start standard applications such as manual operation, analog operation with 4-20mA, 1/1 pulse operation and external operation with External ON, without having to make further adjustments. It is only necessary to select the operation mode from the respective menu (see Chapter 11.6) and, in case of external control, to connect the respective input (see Chapter 10.3.1).

The references to the respective chapters facilitate the adjustment of the settings to special applications and dosing tasks.

In addition, the parameter table offers the possibility to document the changes that have been made in the settings. Thus, the current settings of the pump can be viewed quickly at any time.

	Factory settings	Chapter	Modification 1	Modification 2	Modification 3
Pulse operation:					
Pulse mode	1/1	11.7.2			
Pulse factor	1	11.7.2			
Pulse memory	ON	11.7.2			
Analog mode:					
Analog mode	Auto	11.7.1			
Analog signal	4-20mA	11.7.1			
Adjustment: Analog I1	4 mA	11.7.1			
Adjustment: Frequency f1	0 %	11.7.1			
Adjustment: Analog I2	20 mA	11.7.1			
Adjustment: Frequency f2	100 %	11.7.1			
Batch mode:					
Batch control	Manual	11.7.3			
Batch quantity	0 strokes	11.7.3			
Batch start	00:00 h	11.7.3			
External mode:					
Stroke freq.	100 %	11.7.4			
Input 01:					
Function E1	Pulse	11.8.1			
Contact E1	Normally open	11.8.1			
Input 02:					
Function E2	Analog 01	11.8.2			
Contact E2	Normally open	11.8.2			
Input 03:					
Function E3	External ON	11.8.2			
Contact E3	Normally open	11.8.2			
Output 01:					
Function A1	Collective fault	11.8.3			
Contact A1	Normally closed	11.8.3			
Output 02:					
Function A2	Stroke signal	11.8.3			
Contact A2	Normally open	11.8.3			
Dosing monitor.:					
Sensor	OFF	11.12			
Function	Message	11.12			
Fault stroke	10	11.12			
Alarm limit	80%	11.12			
Level:					
Pre-alarm	Normally open	11.15.4			
Dry run	Normally open	11.15.4			
System:					
Language	German	11.11			
Calibration	OFF	11.11			
SLOW-Mode:					
Slow-Mode	OFF	11.15.1			
Speed	80 %	11.15.1			
Password:					
PW01 mode	OFF	11.13			
Password 01	9990	11.13			
Password 02	9021	11.13			
Diaphragm rupture indication					
Input signal	Normally open	11.15.3			
Sensitivity	50%	11.15.3			

Tab. 10 Parameter

Operating instructions

11.5 Menu

You can switch between the following three screens:

- Operating messages
- Main menu
- Fault and warning messages

A change to the screen "Fault and warning messages" is only possible when a fault or warning is present.

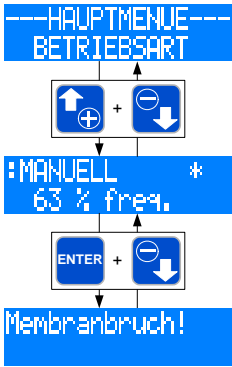

A change between the screens "Operating messages" and "Main menu" is done by simultaneously pressing the UP and DOWN keys.

A change between the screens "Operating messages" and "Fault and warning messages" is done by simultaneously pressing the ENTER and DOWN keys.

NOTE ! 

After, in the main menu, no key has been pressed for 3 min. the screen "Operating messages" is automatically displayed.

11.5.1 Screen "Operating messages"

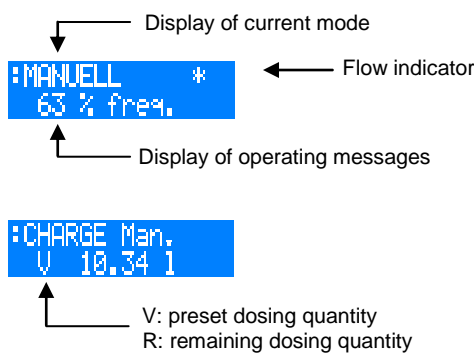

Display of the current operation mode

The first line in the screen "Operating messages" shows the currently set operation mode.

Flow indicator

A star-symbol (*) in the first line on the right-hand side is used as flow indicator. The star symbol indicates the response of a connected dose monitoring instrument (flow control or flow meter).

NOTE ! 

The flow indicator (*) is only active when a flow control / flow meter is connected and the dosing monitoring is activated (see Chapter 11.15.1).

Display of operating messages

The second line of the display shows, dependent on the set operation mode, a variety of operating messages (e.g. the current stroke frequency, total strokes – see Tab. 11). The operating messages can be scrolled using the UP and DOWN keys.

You can use the ENTER key to open the value input fields of the editable operating messages (see Tab. 11). The value input is described in Chapter 11.5.4.

Operating messages	Operation mode				
	Manual	Analog	Pulse	Batch	External
Current stroke frequency	○ ⁽¹⁾	●	●	●	●
Current dosing performance ⁽²⁾	○	●			
Total strokes	○	○	○	○	○
Total dosing quantity ⁽²⁾	○	○	○	○	○
Current control current		●			
Pulse factor			●		
Memory			●	●	
Dosing quantity / strokes				●	
Remaining dosing quantity / remaining strokes				●	
Manual start				●	

● = Indication
○ = Indication and setting option
⁽¹⁾ = not with a calibrated pump
⁽²⁾ = only with a calibrated pump

Tab. 11 Operating messages in dependence on the selected operation mode

11.5.2 Fault and warning messages

When a fault or warning has occurred, the dosing pump shows a message in plain text format on the LCD display.

NOTE ! 

The message disappears automatically when the cause of the fault or warning has been eliminated.

Operating instructions

11.5.3 Screen “Main menu”

The upper line shows the superordinate menu items or editable parameters. The lower line shows the subordinate menu items or selectable values and settings.

Superordinate menu items are marked with “---” (see example). Superordinate means that no values or settings can be assigned to this item.

It is, for example, possible to select a variety of subordinate menu items (e. g. ANALOG MODE) in the ---PARAMETER--- menu but these items cannot be assigned to the superordinate menu as a fixed value.



(Example for the display of superordinate menu items)

Parameters which can be assigned different values or settings are marked with “>” and “<”. Such parameters are, for example, the operation mode, the analog signal or the pulse mode. Each parameter should be assigned a definitive value or setting. The >OPERATION MODE< can, for example, be assigned the ANALOG setting (see example).



(Example for the display of parameters)

11.5.4 Value entry

The assignment of values and settings to a parameter is described in the following, using two exemplary illustrations.

Assignment of settings

(Example: Selection of operation mode)



Display of the current setting (in this example: MANUAL operation mode).



Value entry is enabled after pressing the ENTER key.



Then, the operation mode indicator flashes and a setting can be selected (in this example: operation modes) using the UP and DOWN keys.



After a setting has been selected (in this example: ANALOG mode), pressing the ENTER key will confirm and save the choice.



Display of the current setting (in this example: ANALOG mode)

Assignment of values

(Example: Selection of the pulse factor in case of division)



Display of the current value (in this example: pulse factor 1/1)



Value entry is enabled after pressing the ENTER key.



Then, the first digit of the pulse factor flashes.



The desired figure can be set using the UP and DOWN keys (in this example: 1).



After having selected the desired figure, pressing the ENTER key will confirm the choice.



Then, the second digit of the pulse factor starts to flash.



The desired figure can be set using the UP and DOWN keys (in this example: 0).



After having selected the desired figure, pressing the ENTER key will confirm the choice.



Then, the third digit of the pulse factor starts to flash.



The desired figure can be set using the UP and DOWN keys (in this example: 0).



After having selected the desired figure, pressing the ENTER key will confirm the choice.



Afterwards, the entered value will be saved.



Display of current value (in this example: pulse factor 100/1)

The value entry (flashing indication) can be exited by simultaneously pressing the UP and DOWN keys. In this case, the previous value / previous setting will be maintained.

NOTE !



If, during the value entry (flashing indication), no key has been pressed for 30 sec. the entry mode is exited automatically and the previous value / previous setting is maintained.

Operating instructions

11.5.5 Menu guide

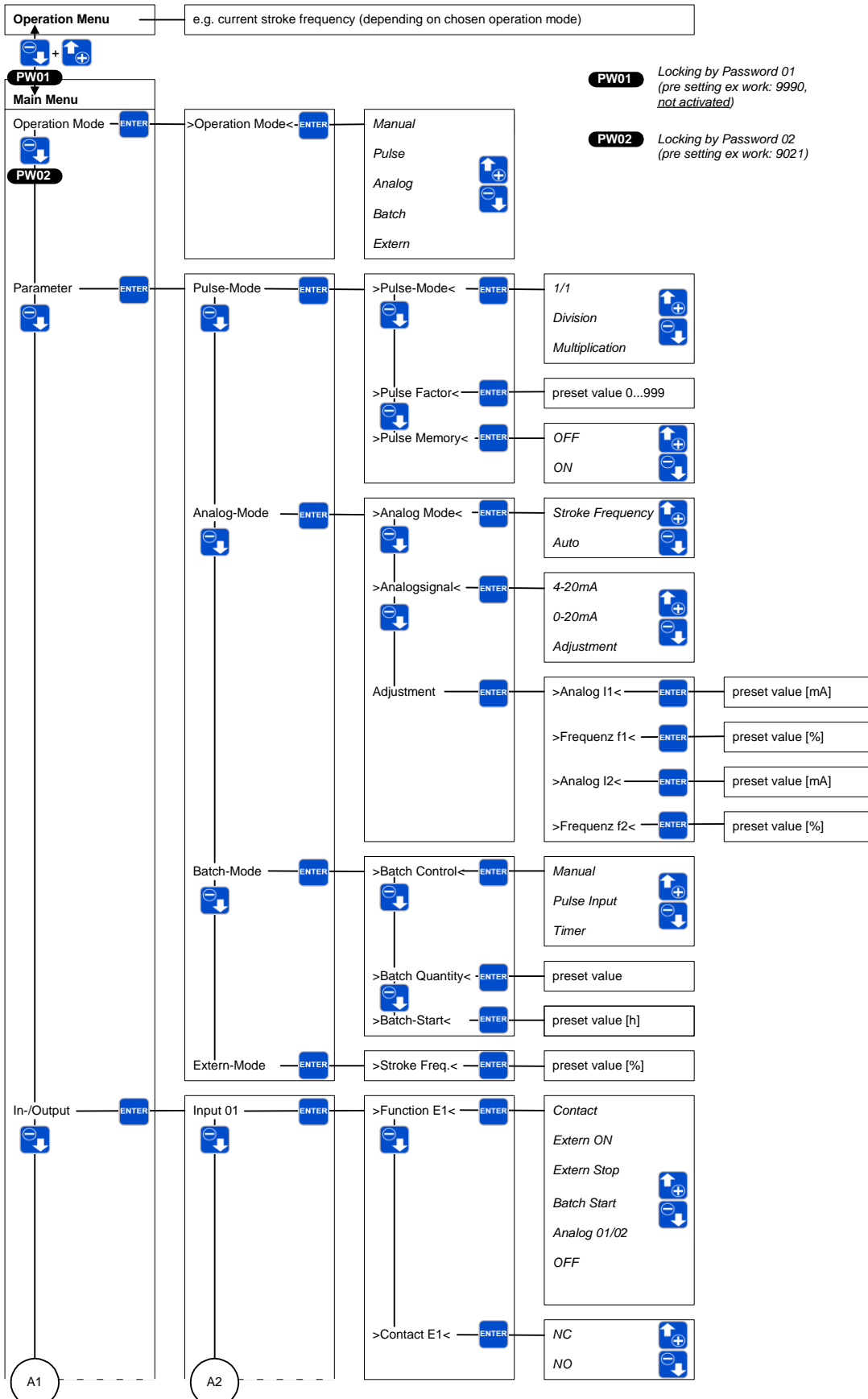

Operating instructions

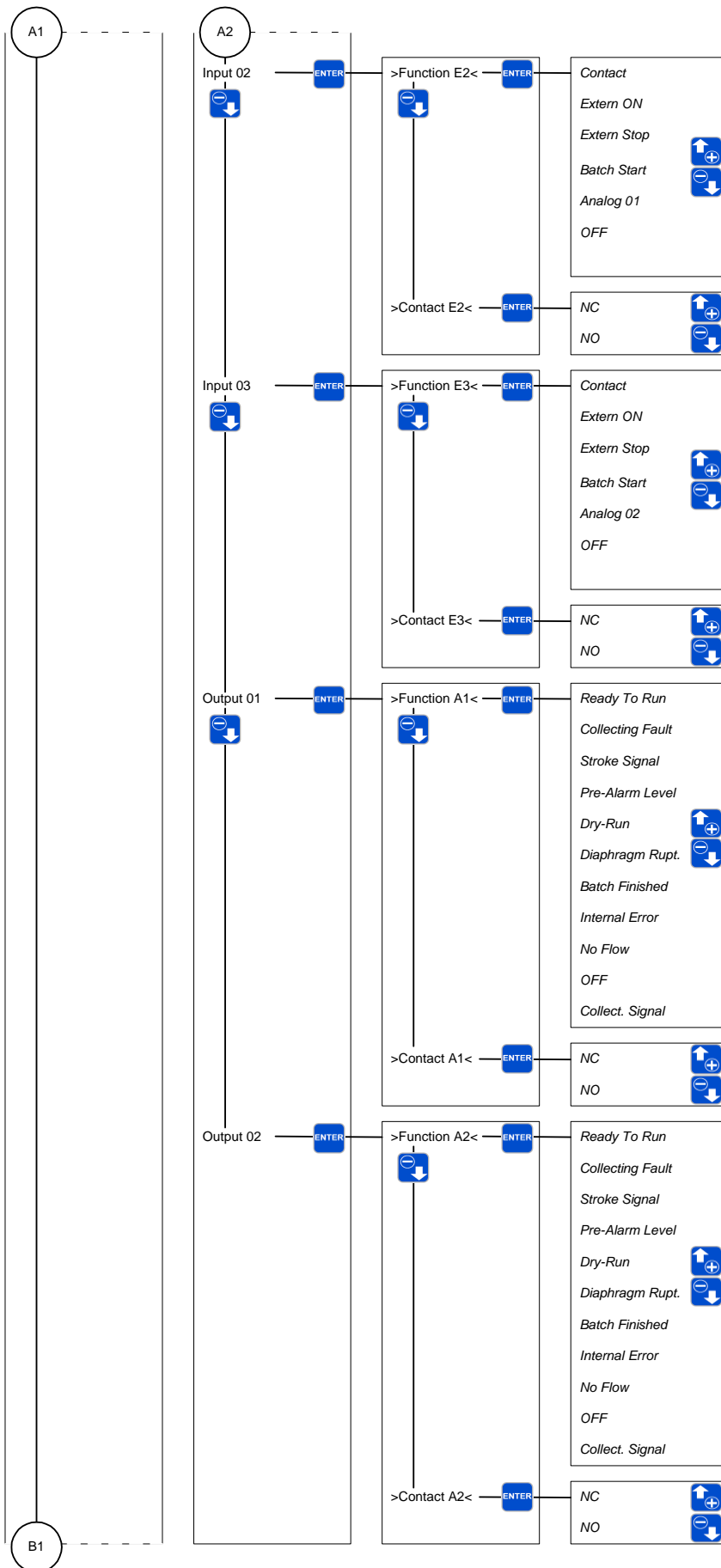

Operating instructions

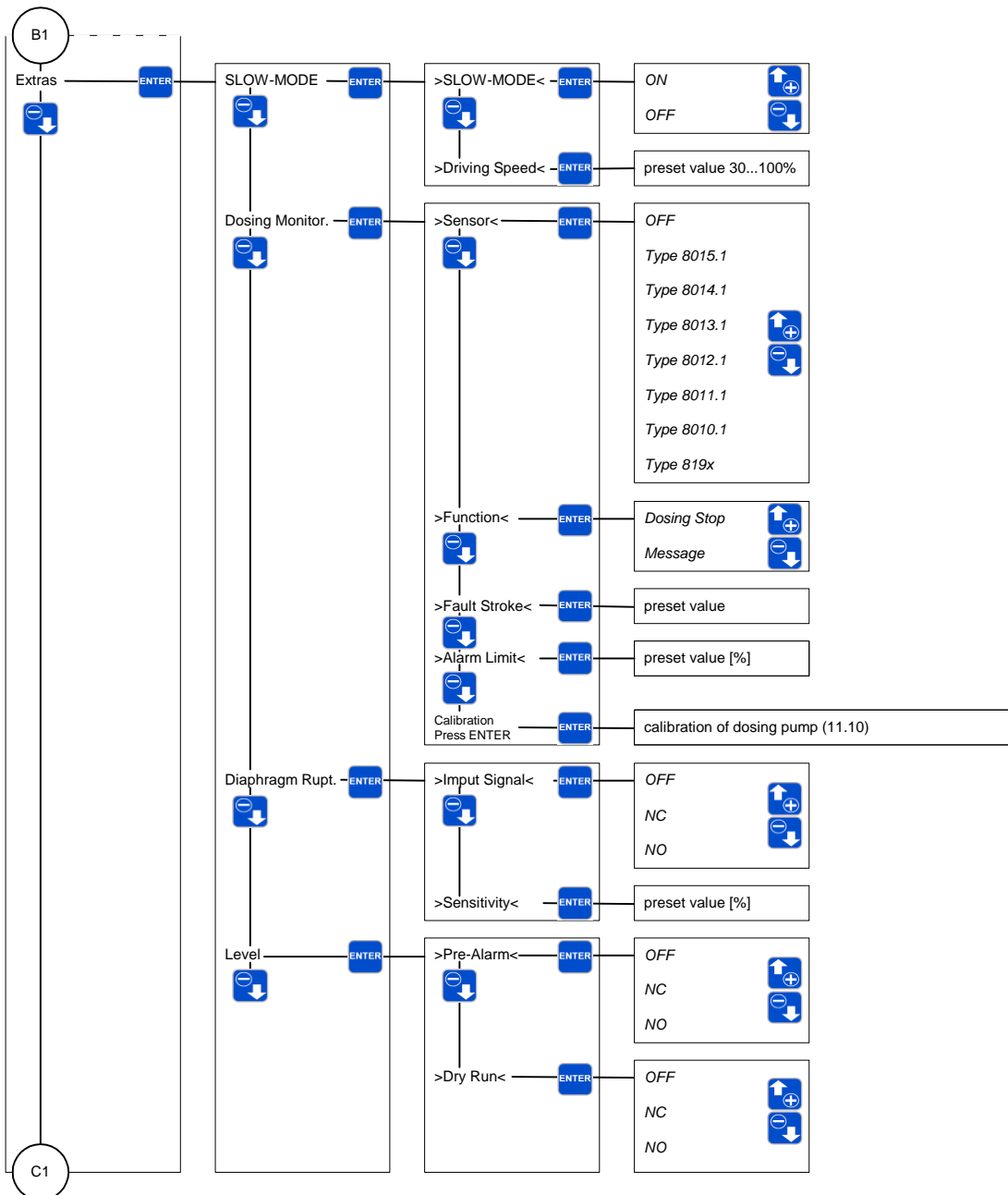

Operating instructions

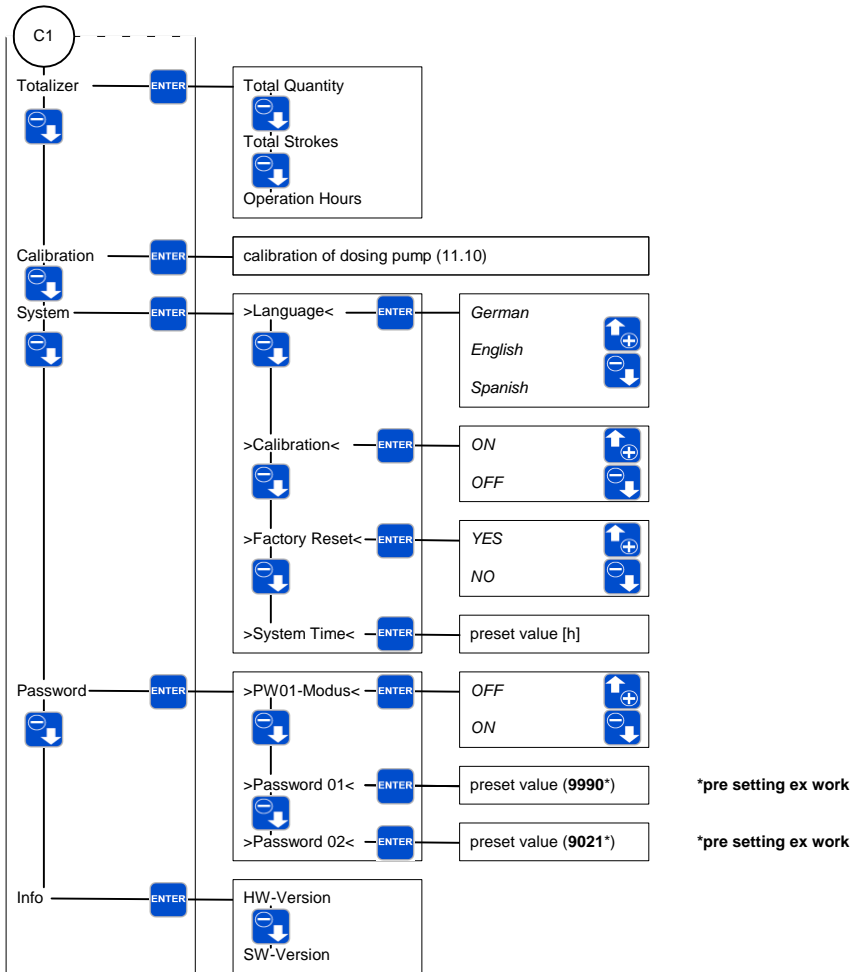

Operating instructions

11.6 Selecting the operation mode

You can select among five different operation modes:

- MANUAL
- PULSE
- ANALOG
- BATCH
- EXTERNAL

```
>OPERATION MODE<
MANUAL
```

On-site operation and on-site control of the pump without external control. The flow rate can be set via the manual stroke length adjustment and/or by presetting a stroke frequency. With a calibrated pump, the delivery rate is set in l/h instead of via the stroke frequency.

```
>OPERATION MODE<
EXTERN
```

The pump is released or blocked via an external switch. If the pump is released, it will run at the preselected stroke frequency (see Chapter 11.7.4).

```
>OPERATION MODE<
BATCH
```

Batch dosing that can either be started manually, via an external pulse signal or by time control. The batch quantity can be entered in strokes or in liters (only with a calibrated pump) (see Chapter. 11.7.3).

```
>OPERATION MODE<
ANALOG
```

The stroke frequency of the pump is controlled via the received analog signal. The pump can optionally be controlled with a control current of either 0...20mA or 4...20mA. In addition, there is the possibility to adjust the receiving analog signal according to needs (see Chapter 11.7.1).

```
>OPERATION MODE<
PULSE
```

Three pulse modes are offered. The pump can either be operated in the 1/1 mode or with multiplication or division of the input pulses (see Chapter 11.7.2).

Setting diagram:

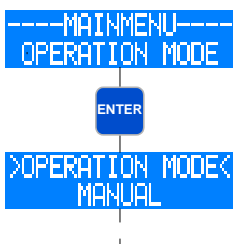

Go to the ---MAIN MENU--- and select the menu item OPERATION MODE (if necessary, use the UP / DOWN keys). Pressing the ENTER key will open the >OPERATION MODE< submenu.

Here, the currently set operation mode is indicated (in this example: MANUAL).

The adjustment of an operation mode is done in accordance with the description in Chapter 11.5.4.

11.7 Additional settings for the operation mode

Depending on the selected operation mode, specific settings can be made.

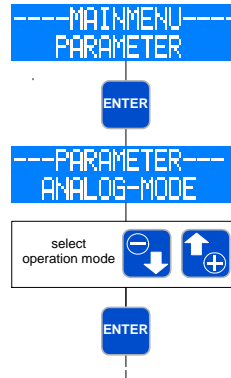

Go to the ---MAIN MENU--- and select the menu item PARAMETER (if necessary, use the UP / DOWN keys). Pressing the ENTER key will open the --- PARAMETER --- submenu.

Here, the currently set operation mode is indicated (in this example: ANALOG MODE).

The DOWN key is used to move to the respectively next operation mode. The UP key is used to move to the previous operation mode. When in the PULSE MODE, the UP key is used to move back to the ---MAIN MENU---.

After having selected the operation mode, the ENTER key can be used to move to the specific settings for the selected operation mode.

NOTE !



In the ---PARAMETER--- menu, there is no adjustment possibility for the MANUAL operation mode.

11.7.1 Additional settings for the ANALOG operation mode

NOTE !



In order to be able to use the ANALOG operation mode, at least one input must be assigned the ANALOG 01 or ANALOG 02 function (see Chapter 11.8.2). Input 02 (see Chapter 10.3.1) is factory preset to analog input (ANALOG 01).

Choose the ANALOG MODE

Two different analog modes can be chosen:

- Auto
- Stroke frequency

```
>ANALOG-MODE<
AUTO
```

The motor speed is adjusted corresponding to the stroke frequency. If the stroke frequency falls below 30% operation changes to Stop&Go.

```
>ANALOG-MODE<
STROKE FREQUENCY
```

Stop&Go operation covering the whole stroke frequency range, that means every stroke is performed with full motor speed.

Operating instructions

Selecting the ANALOG SIGNAL

You can select among three different analog signals:

- 4-20mA
- 0-20mA
- ADJUSTMENT

```
>ANALOGSIGNAL<
4-20mA
```

A signal with a control current of 4mA corresponds to 0% stroke frequency; a signal with 20mA corresponds to 100% stroke frequency. In this range, the stroke frequency behaves proportionally to the control current (Fig. 45).

If the input signal is < 3.5mA, then the pump emits the error message "Analogsignal < 4mA". Thus, a wire breakage (control current = 0mA) can be detected.

If the input signal is > 20.5mA, then the pump stops and the error message "Analogsignal > 20 mA" is emitted.

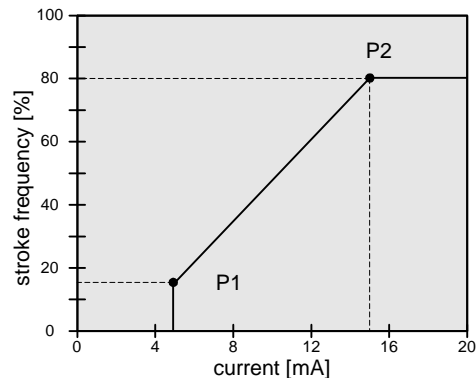

Fig. 45 (Exemplary adjustment of the analog signal)

```
>ANALOGSIGNAL<
0-20mA
```

A signal with a control current of 0mA corresponds to 0% stroke frequency; a signal with 20mA corresponds to 100% stroke frequency. In this range, the stroke frequency behaves proportionally to the control current (Fig. 44).

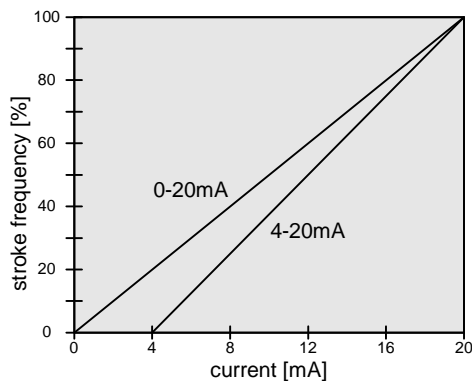

Fig. 44 Stroke frequency in dependency on the control current at 4-20mA / 0-20mA)

```
>ANALOGSIGNAL<
ADJUSTMENT
```

The analog control signal can be adjusted according to needs. This is, for example, necessary if a connected regulator provides a limited output signal.

Two points are given that reflect a proportional relation between control current and stroke frequency of the pump. In addition, these two points restrict the stroke frequency range of the pump as shown in Fig 45.

Example: Point 1: 15% stroke frequency at 5mA
 Point 2: 80% stroke frequency at 15mA

If the control current is < 5mA, then the stroke frequency of the pump is 0%.

If the control current is > 15mA, then the stroke frequency of the pump is 80%.

CAUTION !

If the input signal is greater than 25 mA, the pump stops and a fault indicator „analog signal > 25 mA“ is emitted. Additionally in this case, the appropriate input will be switched off as protective measure. The input is reactivated after the dosing pumps is switched off and started again via the button STOP/START.

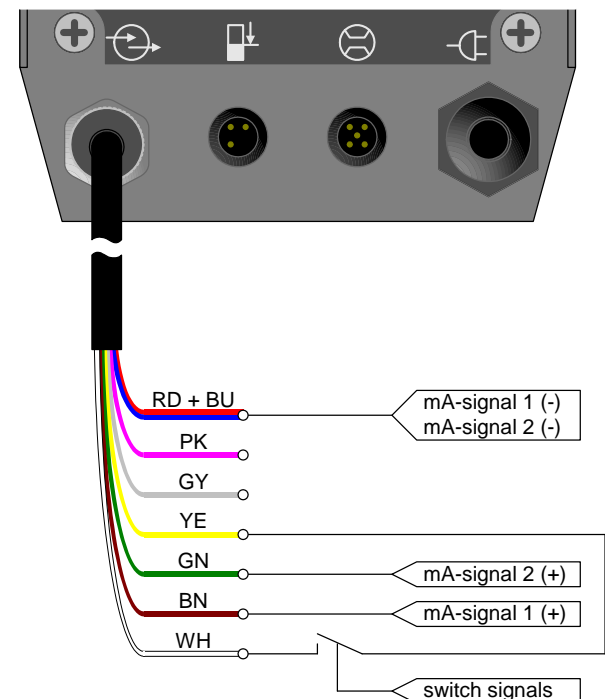

Fig. 46 (Connection of two analog signals with switch-over)

Operating instructions

ADJUSTMENT of the analog signal

The adjustment of the analog signal is done under consideration of two default points. These two points are two value pairs which assign control currents to stroke frequencies:

Point 1 (I1, f1)
Point 2 (I2, f2)

The following diagram shows the procedure to determine the points.

Setting diagram:

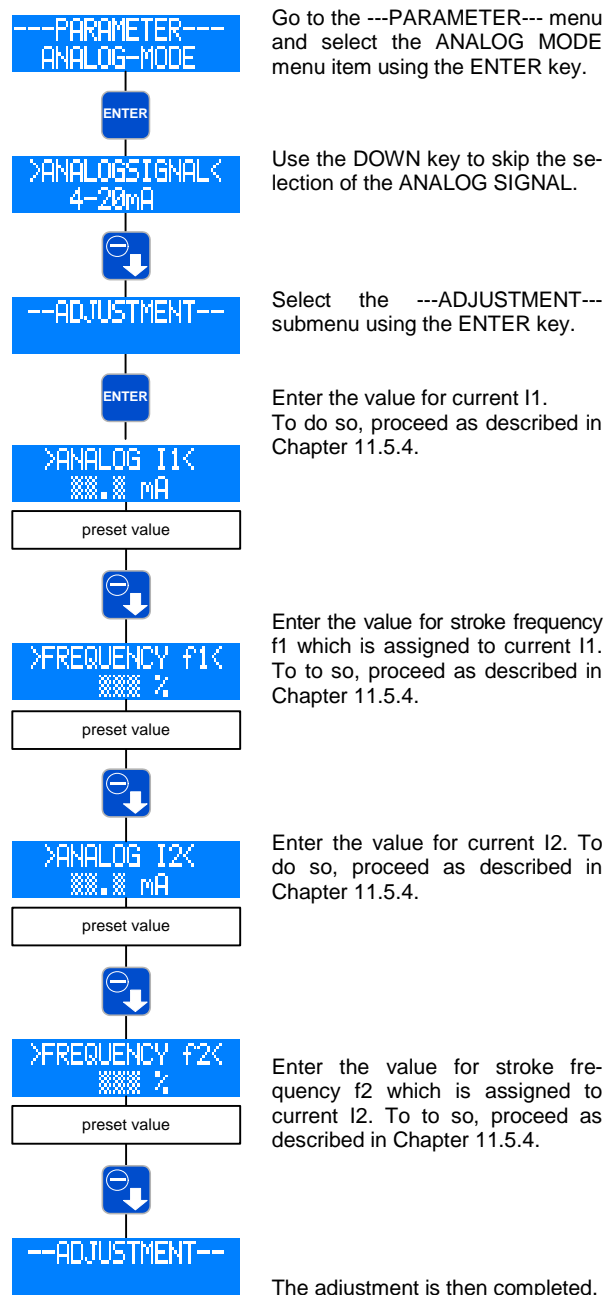

11.7.2 Additional settings for the PULSE mode

NOTE !



In order to be able to use the PULSE operation mode, at least one input must be assigned the PULSE function (see Chapter 11.8).
Input 01 (see Chapter 10.3.1) is factory preset to pulse input (ANALOG 01).

Selecting the PULSE MODE

You can select among three different pulse modes:

- 1/1
- DIVISION
- MULTIPLICATION

>PULSE MODE<
1/1

In this mode, the pump performs exactly one stroke for each received pulse.

>PULSE MODE<
DIVISION

In this mode, a division of the received pulses is performed. This means that a stroke will only be performed after an adjustable number of pulses (division factor) has been received.

>PULSE MODE<
MULTIPLICATION

In this mode, a multiplication of the received pulses is performed. This means that the pump will perform an adjustable number of strokes (multiplication factor) after every received pulse.

Selecting the PULSE FACTOR

Depending on the selected pulse mode, the pulse factor corresponds either to the division factor or the multiplication factor.

>PULSE FACTOR<
50/1

The **division** factor can be selected between 1 and 999. If, for example, the division factor is 50, then the pump will perform a stroke only with every 50th received pulse.

>PULSE FACTOR<
1/50

The **multiplication** factor can be selected between 1 and 999. If, for example, the multiplication factor is 50, then the pump will perform 50 strokes with every received pulse.

For setting the pulse factor, please see the description in Chapter 11.5.4 (Assignment of values).

Operating instructions

Switching ON/OFF the PULSE MEMORY

The pump is equipped with a pulse memory, which can optionally be switched ON and OFF. 999 strokes max can be saved. If the number of received pulses exceeds the number that can be handled by the pump, then the pulses will be buffered and the strokes will be performed later.

Example: With the setting 1:50, 5 pulses are in the memory → perform. of 5 x 50 strokes = 250 strokes.

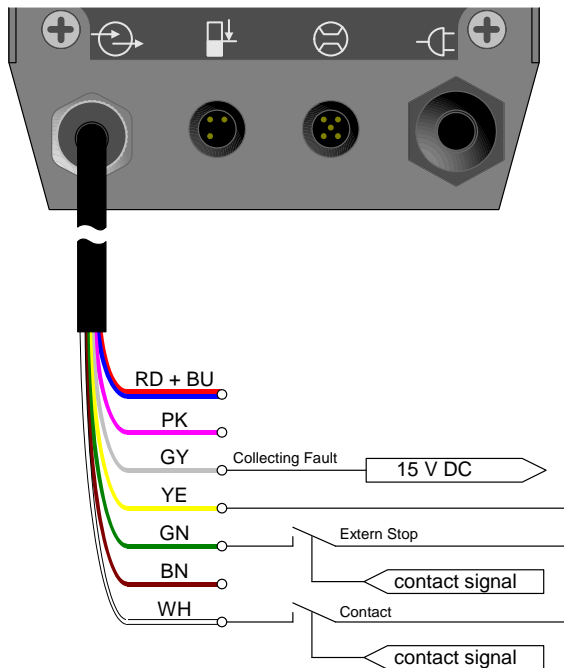

Fig. 47 Connection of a pulse signal with External stop and response of the stroke signal)

11.7.3 Additional settings for the BATCH mode

Selecting the type of CONTROL

You can select among three different types of control:

- MANUAL
- TIMER
- PULSE INPUT

>CHARGE CONTROL<
MANUAL

With this type of control, the batch is started manually in the “operating messages” screen by pressing the ENTER key.

>CHARGE CONTROL<
TIMER

With this type of control, the batch is started **daily** at a fixed adjustable time (system time of the pump).

CAUTION ! 

The pump starts the batch when the preset time matches the system time of the pump. When the supply voltage is switched off, then the system time will be reset to 0:00.

CAUTION ! 

If the **TIMER** control is set, then the batch dosing will be repeated **daily** at the set time.

>CHARGE CONTROL<
PULSE INPUT

With this type of control, the batch is started via an external pulse at the pulse input.

NOTE ! 

In order to be able to use the **PULSE INPUT** control, at least one input must be assigned to the **START BATCH** function (see Chapter 11.8).

Determining the BATCH QUANTITY

The type of entry for the batch quantity depends on the calibration (see Chapter 11.10):

- Entry in strokes if the pump is not calibrated
- Entry in liters if the pump is calibrated

Operating instructions

Adjusting the STROKE FREQUENCY

The stroke frequency at which the pump works during batch dosing can be adjusted.
The value input is described in Chapter 11.5.4.

Determining the BATCH START



The pumps starts the batch dosing when the system time of the pump matches the value entered under BATCH START.

The value input is described in Chapter 11.5.5.

NOTE ! 

In order to enable time-controlled batch dosing, TIMER control must be set under BATCH MODE.

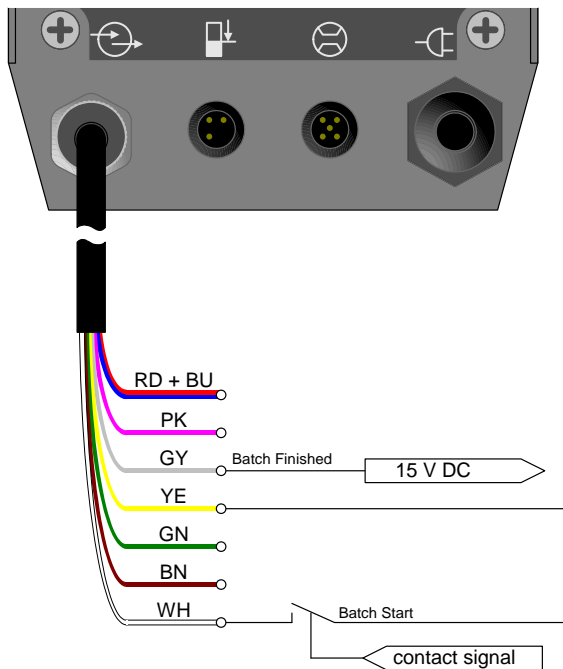



Fig. 48 Possible connector pin assignment in batch mode

11.7.4 Settings for the EXTERNAL operation mode

NOTE ! 

In order to be able to use the EXTERNAL operation mode, at least one input must be assigned the EXTERNAL ON function (see Chapter 11.8). Input 03 (see Chapter 10.3.1) is factory preset to External ON.



In the EXTERNAL operation mode, only one stroke frequency (e.g. 63%) can be set. As soon as an external ON signal is received, the pump will start running at this stroke frequency.

The value input is described in Chapter. 11.5.5

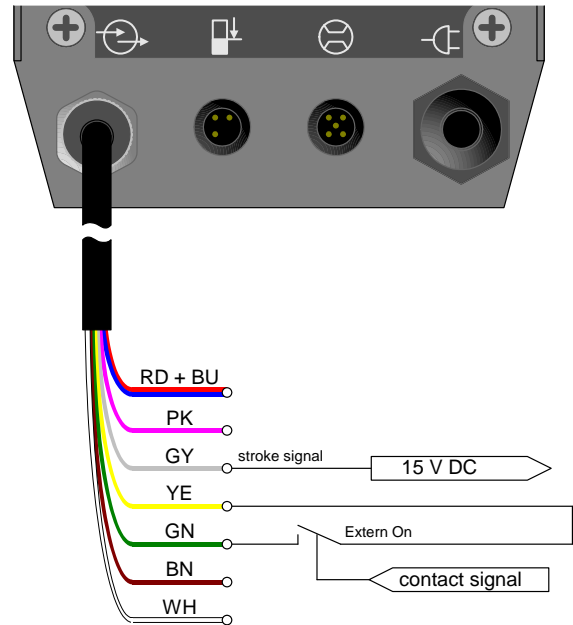



Fig. 49 Possible connector pin assignment in External operation mode

11.8 Configuring the inputs and outputs

The pump is equipped with three inputs and two outputs, which can be configured via a menu and thus be adapted to the given operating conditions.
It is possible to assign the same functions to all three inputs.

NOTE ! 

If several inputs are configured identically, then the input signals will be evaluated via OR-operation. This means that the function will be performed as soon as one of the inputs fulfils the condition.

Exception: Pulse input with pulse memory. If the pulse memory is switched on, then the received pulses will be summed up.

Operating instructions

Setting diagram:

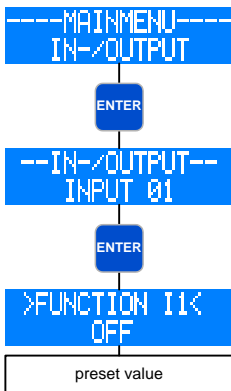

Go to the ---MAIN MENU--- and select the menu item IN-/OUTPUT (if necessary, use the UP / DOWN keys). Pressing the ENTER key opens the ---IN-/OUTPUT--- submenu.

Here, you can select among the individual inputs and outputs.

Pressing the ENTER key opens the menu level for setting the individual inputs and outputs.

11.8.1 Digital input 01

Input 01 can be assigned one of six different functions. Optionally, it can also be switched off.

- Pulse
- External On
- External Stop
- Batch Start
- Analog 01/02
- OFF

In addition, it is possible to configure the contact signal of the input as NC or NO.



Configuration of the respective input as pulse input.



Function for externally switching on the pump via the respective input (only with the EXTERNAL operation mode).



Function for externally switching off the pump via the respective input (independent of the operation mode).

NOTE !

If the dosing pump is switched off via External Stop, then an "S" will be indicated in the 1. line of the display on the right-hand side.





Function for externally starting the batch via the respective input.



This function is used to switch over between the two analog inputs Analog 01 and Analog 02 (input 02 and 03) via input 01. Selection of the analog input is done in accordance with the following Tab. 10.

Configuration Contact E1	Applied signal	Selected analog input
NC	High	Analog 01 (input 02)
NC	Low	Analog 02 (input 03)
NO	High	Analog 02 (input 03)
NO	Low	Analog 01 (input 02)

Table. 12 Analog input switchover



The respective input is not assigned a function.

11.8.2 Digital/analog inputs 02 and 03

Basically, input 02 and input 03 have the same functions as input 01 (see Chapter 11.8.1). In addition, they can also be used as analog inputs. However, the function "Analog 01/02", which is used to switch over between the analog inputs is not available.

In addition, it is possible to configure the contact signals of the inputs as NC or NO.



Respective input is configured as analog input.

11.8.3 Outputs 01 and 02

Each of the outputs 01 and 02 can be assigned one of ten different functions. Optionally, they can also be switched off.

- Ready to run
- Collective fault
- Collect. signal
- Stroke signal
- Pre-alarm level
- Dry run
- Diaphragm rupture
- Batch finished
- Internal error
- No flow
- OFF

Operating instructions

In addition, it is possible to configure the contact signals of the outputs as NC or NO.

```
>FUNCTION 01<
READY TO RUN
```

Message from the respective output indicating the readiness of the dosing pump.

```
>FUNCTION 01<
COLLECTING FAULT
```

Message if one of the following faults occurs:

- Diaphragm rupture
- Dry run
- Internal error
- No flow (with DOSING STOP function)

```
>FUNCTION 01<
COLLECT. SIGNAL
```

Message indicating that one of the following faults has occurred:

- All faults of the collective faults
- Pre-alarm level
- No flow (with MESSAGE function)

```
>FUNCTION 01<
STROKE SIGNAL
```

Message from the respective output indicating that a stroke has been performed.

```
>FUNCTION 01<
PRE-ALARM LEVEL
```

With activated 2-stage level monitoring, message from the respective output indicating a pre-alarm.

```
>FUNCTION 01<
DRY RUN
```

With activated level monitoring, message from the respective output indicating the dry run.

```
>FUNCTION 01<
DIAPHRAGM RUPT.
```

With activated diaphragm rupture monitoring, message from the respective output indicating a diaphragm rupture.

```
>FUNCTION 01<
BATCH FINISHED
```

With activated BATCH operation mode, message from the respective output indicating that the batch is finished.

```
>FUNCTION 01<
INTERNAL ERROR
```

Signal when one of the following listed faults occurs (fault analysis/- causes see chapter 14.1):

- Fault drive
- Fault stroke sensor
- No stroke recognition
- Set value not attained

```
>FUNCTION 01<
NO FLOW
```

With activated flow control, message from the respective output indicating that the permitted number of fault strokes has been exceeded.

11.9 Flow rate indicator

NOTE !



If the dosing pump has not been calibrated, then the flow rate indicator will not be activated.

The flow rate indicator is activated via the calibration of the pump (see Chapter 11.10). The display depends on the operation mode.

MANUAL operation mode

```
:MANUAL 7.2 l/h    :MANUAL 10.34 l
```

After calibration of the dosing pump, the flow rate is entered directly as target value in l/h instead of via the stroke frequency adjustment. In the screen "operating messages" (see Chapter Fehler! Verweisquelle konnte nicht gefunden werden.), the stroke frequency indicator is replaced by the flow rate indicator. In addition, the total dosing quantity is indicated in litres.

ANALOG operation mode

```
:ANALOG 7.2 l/h    :ANALOG 10.34 l
```

The calibration of the pump activates the flow rate indicator and the stroke frequency remains also visible. In addition, the total dosing quantity is indicated in litres.

BATCH operation mode

```
:BATCH Man. U 10.34 l    :BATCH Man. R 10.34 l
```

After calibration of the dosing pump, dosing quantity and remaining dosing quantity are indicated in litres.

PULSE operation mode

```
:PULSE 10.34 l
```

After calibration of the dosing pump, the total dosing quantity is also indicated in litres.

Operating instructions

Standard flow rate indicator

With the standard flow rate indicator, the entered target value is converted into the corresponding stroke frequency. The maximum adjustable target value is limited by the internally determined stroke length.

Example: The calibration at 50% stroke length results in a flow rate of 10l/h (at 100% stroke frequency). If a target value of 8l/h is entered, then the stroke frequency is accordingly reduced to 80%. The maximum target value in this case is 10l/h. It can be changed via the stroke length adjustment (+/- 10%).

Internal calculation:
100% stroke frequency → Measure in litres: 10l/h
Target value: 8l/h → 80% stroke frequency

Flow rate indicator with flow meter

The flow meter records the actual value, and if the flow rate deviates from the entered target value, the dosing pump will readjust it.

CAUTION ! 

If the pump already works with 100% stroke frequency, there is no possibility of an additional capacity adjustment upwards. If the set value is fallen below, the warning signal "flow too low" appears.

The maximum adjustable target value is limited by the internally determined stroke length.

Example: The calibration at 50% stroke length results in a delivery rate of 10l/h (at 100% stroke frequency). If a target value of 8l/h is entered, then the stroke frequency is at first accordingly reduced to 80%. The flow meter measures a delivery rate of 7.9l/h. The internal control increases the stroke frequency to 81% in order to achieve 8l/h. The maximum target value in this case is 10l/h. It can be changed via the stroke length adjustment (+/- 10%).

Internal control:
100% stroke frequency → Measure in litres: 10l/h
Target value: 8l/h → 80% stroke frequency
80% stroke frequency → Actual value: 7.9l/h
8l/h → 81% stroke frequency

CAUTION ! 

In order to enable an effective capacity adjustment, pay attention that the given set value is attained when having a stroke frequency of < 100 %. A max. nominal stroke frequency of approx. 80 % is recommended in order to enable an adjustment of the capacity when the set value is fallen below.

NOTE ! 

The set value in l/h can be preset manually (operating mode MANUAL) or by analog signal (ANALOG) as soon as the dosing pump is calibrated.

11.10 Calibration

The calibration is used to activate the flow rate indicator. Calibration is always done in the same way, no matter whether a flow meter is connected or not.

CAUTION ! 

Calibration is performed with a fixed stroke length. The calibration remains valid even if the stroke length is changed by up to +/- 10%. If this calibration range is exceeded, then the warning message "Out of range" will be displayed.

Sequence of calibration:

CAUTION ! 

Prior to the calibration of the flow rate indicator with connected flow meter, the sensor type (>SENSOR<) must be set. If no sensor type is set (OFF), then the calibration will only activate the standard flow rate indicator.

CAUTION ! 

Pay attention to the safety data sheet relating to the dosing medium!

Operating instructions

1. Lead the suction line into a calibration pot filled with the dosing medium – the pressure line must be installed in final position, i.e. the operating conditions (backpressure, etc.) must be fulfilled.
2. When the suction line is empty the dosing medium must be drawn in (MANUAL operation mode, keep the pump running).
3. Set the stroke length with which the pump should be calibrated (can also be done via the manual stroke length adjustment)
4. Note the filling level in the calibration pot (= base quantity)
5. Go to the main menu and select the --CALIBRATION--menu:



6. Press the ENTER key to access the field for entering the number of calibration strokes.
7. At first, enter the desired stroke number (at least 200!) → the higher the stroke number the more accurate the calibration!
8. To start the calibration, press the ENTER key.
9. The dosing pump performs the pre-set number of strokes.
10. Determination of the pumped quantity (= difference between base quantity and remaining quantity in the calibration pot).
11. Entry of the determined quantity.

Calibration of the dosing pump is then completed!

NOTE !



After the dosing pump has been calibrated, calibration (see Chapter 11.11) will automatically be set to ON.

CAUTION !



If the operating conditions are changed (supply line, backpressure, etc.), then the dosing pump must be newly calibrated. Otherwise, the flow rate indicator might be inaccurate!

11.11 System

The system settings do not depend on the operation mode. These include:

- Language
- Calibration
- Factory reset
- System time

>LANGUAGE<

You can select between GERMAN; ENGLISH and SPANISH menu texts.

>CALIBRATION<

The calibration of the pump (see Chapter 11.10) can be switched ON and OFF. If the calibration is set to ON and the dosing pump has been calibrated, then the flow rate indicator is activated.

If the calibration is set to OFF and/or the pump has not been calibrated, then the flow rate indicator is not activated.

>FACTORY RESET<

The factory settings (see Tab. 10, Chapter 11.4) can be restored. To do so, adjust YES.

CAUTION !



After restoring the factory default settings, all previous user-defined settings are irrevocably overwritten.

>SYSTEM TIME<

The system time must be adjusted manually.

CAUTION !



If the supply voltage is switched off, then the system time will be reset to 0:00. This means it must be set again.

Operating instructions

11.12 Totalizer

The totalizer indicates the total quantity conveyed, the total strokes and the pump's operating hours. These values are for information purposes and cannot be reset.

11.13 Password

Two password levels are provided to increase the operating safety of the pump. The passwords for these levels consist of a four-digit number code and are individually selectable. Password 01 (PW01) is used to protect the setting of the operation mode (Level 01). This password can be activated and deactivated (when leaving the factory, it is deactivated). Password 02 (PW02) protects all further setting options of the main menu (Level 02, see "Menu guide"). This password protection cannot be deactivated.

NOTE ! 

If, during the 1. password request (Level 01), password 02 has been entered, then Level 02 is also automatically activated.

CAUTION ! 

The passwords are factory set as follows:

- Password 01: 9990 (deactivated)
- Password 02: 9021 (cannot be deactivated!)

Setting diagram:

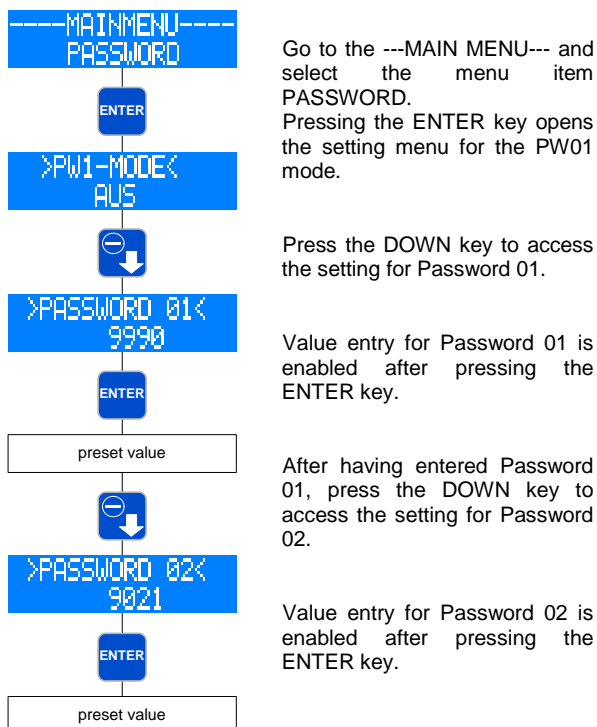

CAUTION ! 

There is an automatic "Logout" after 5 min of inactivity in the "operation modes" screen. Afterwards, the password must be entered again.

CAUTION ! 

Please write down the passwords and keep them in a safe place. When the passwords are lost the pump cannot be configured on site again. In this case, the pump must be sent to the manufacturer's works for configuration release.

11.14 Info

The Info menu item contains information about the hardware and software version of the pump.

11.15 Extras

11.15.1 Slow-Mode



In Slow Mode the pump is operated with reduced speed. This is, for example, reasonable for the feeding of very viscous media.

Adjustments can be made to the following points:

- SLOW-MODE
- Speed

>SLOW-MODE<

Switching-on/Switching-off of the Slow Mode.

> SPEED <

Input of the speed when Slow Mode is activated. The speed can be set between 100 and 30 %.

NOTE ! 

The entered speed in Slow Mode corresponds to the maximum stroke frequency the pump is operated. The maximal possible capacity is reduced correspondingly.

The following is valid for the pulse and analog operation: Every stroke is performed with this speed.

Operating instructions

11.15.2 Dosing monitoring

--EXTRAS-- DOSING MONITOR.

The connection of a **sera** flow controller to the dosing pump will enable the monitoring of the flow rate.
The connection of a **sera** flow meter to the dosing pump will provide a more detailed flow rate indication with regulation of the flow rate (see Chapter 11.9).

CAUTION !



**Prior to the calibration of the flow rate indicator with connected flow meter, the sensor type (>SENSOR<) must be set.
If no sensor type is set (OFF), then the sensor signal will not be considered during calibration.**

It is possible to make adjustments to following items:

- Sensor
- Function
- Fault stroke
- Alarm limit
- Calibration

SENSOR<

Selection of the connected **sera** flow controller or **sera** flow meter.

>FUNCTION<

Selection of the dosing monitoring function. It can be selected whether the dosing monitoring should trigger a warning message (MESSAGE) or a switch-off of the pump (DOSING STOP).

>FAULT STROKE<

Number of fault strokes at which a connected **flow controller** triggers the dosing monitoring.
The factory setting is 10 fault strokes. This means that the dosing monitoring will react if the flow controller does not give a stroke confirmation to the pump for the duration of ten consecutive strokes.

>ALARM LIMIT<

Alarm limit at which a connected **flow meter** triggers the dosing monitoring. The entered value corresponds to the percental part of the target flow rate.
The factory setting is 80%. This means that the dosing monitoring will react if a connected flow meter measures a flow rate which is lower than 80% of the set target flow rate.

---CALIBRATION---

see Chapter 11.10.

11.15.3 Diaphragm rupture detection

--EXTRAS-- DIAPHRAGM RUPT.

The diaphragm rupture detection (see also Chapter 8.2.8) is an optional feature for the dosing pump. It is used to monitor the diaphragm.
It is possible to make adjustments to following items:

- Input signal
- Sensitivity

>INPUT SIGNAL<

Selection between switch-off (OFF) of the diaphragm rupture electrode and a configuration as NO or NC.

CAUTION !



When leaving the factory, the contact type is preset to "switch normally closed".

This setting must not be changed!

>SENSITIVITY<

NOTE !



When leaving the factory, the sensitivity is preset to 70%.

This value must not be changed!

Operating instructions

11.15.4 Level monitoring

--EXTRAS-- LEVEL

The connection of a **sera** suction lance enables the monitoring of the filling level in the dosing tank.

It is possible to make adjustments to following items:

- Pre-alarm
- Dry run

>PRE-ALARM< or >DRY RUN< respectively

Configuration of the two level inputs. It can be selected between either the switch-off (OFF) of the input and a configuration as NC (opening when floating down) or NO (closing when floating down).

When leaving the factory, both level inputs are configured as NO.

Config.	Pre-alarm	Dry run
1	NO	NO
2	NO	NC
3	NC	NC

Tab. 13 Configuration of the level input

Config. 1

When leaving the factory, this configuration is preset. A 1- or 2-stage level monitoring with “closing when floating down” contacts (pre-alarm and dry run or dry run only) can be connected.

Config. 2

This configuration must be selected when a 1-stage level monitoring (dry run only) with “opening when floating down” contact is connected.

Config. 3

This configuration must be selected when a 2-stage level monitoring with “opening when floating down” contacts (pre-alarm and dry run) is connected.

Operating instructions

12 Maintenance

CAUTION !



Before starting maintenance work make sure that the spare- and wearing parts as well as the utilities required are available.
Place / deposit components in such a way that any damage is prevented.

CAUTION !



Check the wearing parts for proper functioning at regular intervals and replace, if necessary.

Check the following conditions at regular intervals:

- tight fit of the the pipework
- tight fit of pressure- and suction valve
- proper condition of the electrical connections
- tight fit of the screws for fastening the pump body (check this at least every three months)
For the tightening torques of the fixing screws, please see Chapter 9.1,table 06)

Repair on the stroke mechanism may only be performed by **sera**.

12.1 Wearing parts

Depending on their use and period of use, wearing parts must be replaced at regular intervals in order to ensure a safe function of the multi-layer diaphragm pump.

We recommend to replace multi-layer diaphragms after 3000 operating hours or at least once a year.

In case of a premature diaphragm rupture caused by hard operating conditions, switch off the multi-layer diaphragm pump and replace the multi-layer diaphragm.

As an option, the multi-layer diaphragm pump can be equipped with a diaphragm rupture signalling device by manometer or pressure switch (see Chapter 12.4).

The following parts are considered as wearing parts of the multi-layer diaphragm pump:

- Multi-layer diaphragm
- Suction valve
- Pressure valve

12.2 Spare parts

The following parts are considered as spare parts of the multi-layer diaphragm pump:

- Pump body
- Pressure switch

Operating instructions

12.3 Spare- and wearing parts

- C 410.2 – 70 ML
- C 410.2 – 135 ML
- C 410.2 – 500 ML
- C 410.2 – 1200 ML

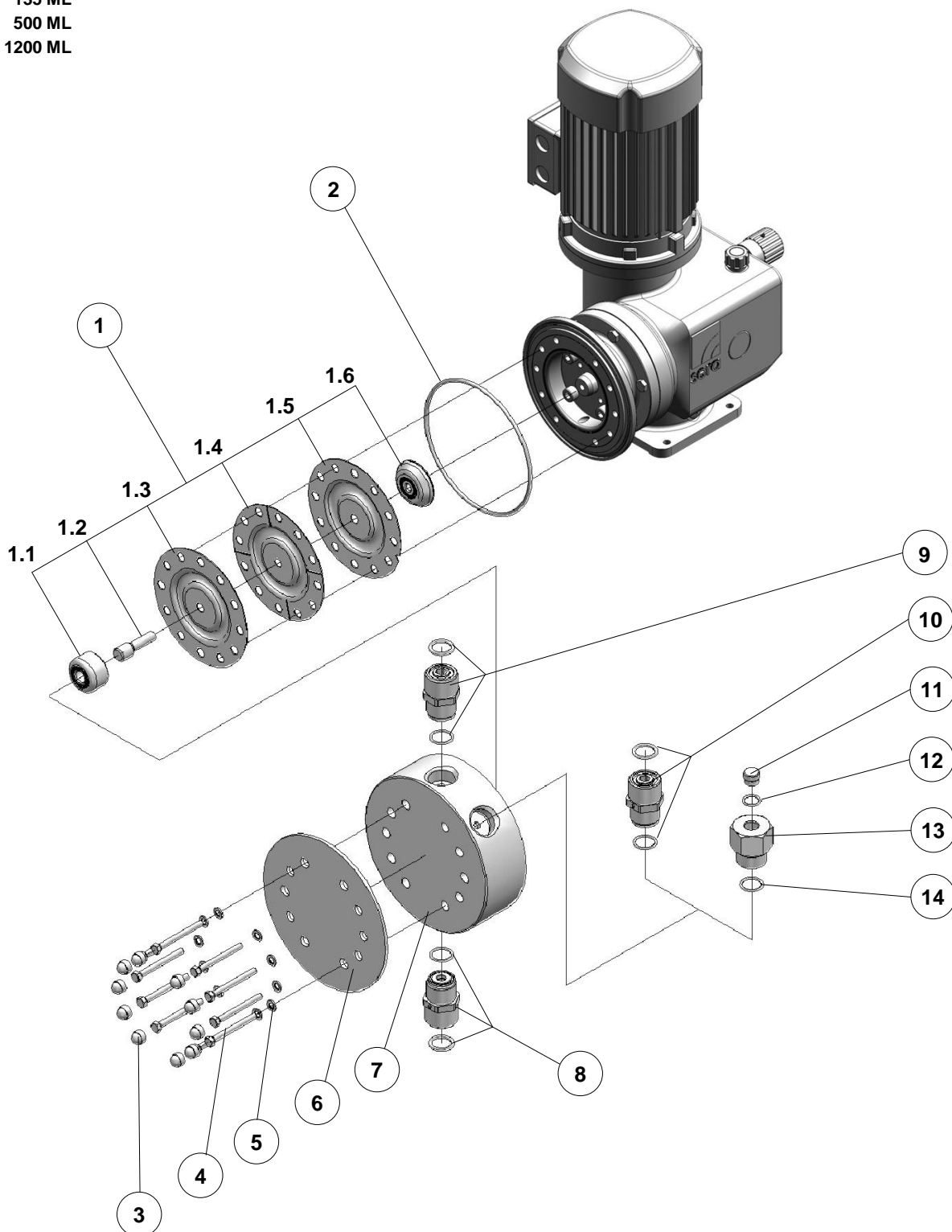

Fig. 50 Spare- and wearing parts

Operating instructions

Overview of the spare- and wearing part kits

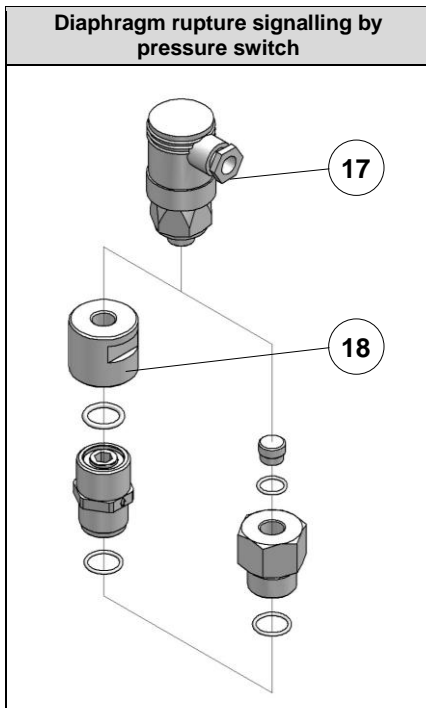

Fig. 51 Spare- and wearing parts

Pump body-Set (plastic)	
Pos.	Designation
3	Protection cap(s)
4	Hexagon head cap screw(s)
5	Disk(s)
6	Vorlegeplatte
7	Pump body
10	Pressure valve (check valve)
18	Transition piece

Pump body-Set (stainless steel)	
Pos.	Designation
3	Protection cap(s)
4	Hexagon head cap screw(s)
5	Disk(s)
7	Pump body
11	Pressure valve (check valve)
12	O-Ring
13	Joint
14	O-Ring

Suction valve (Set)	
Pos.	Designation
8	Suction valve (incl. O-rings)

Pressure valve (Set)	
Pos.	Designation
9	Pressure valve (incl. O-rings)

Diaphragm set	
Pos.	Designation
1	Multi-layer diaphragm package
(1.1)	Pressure plate (front, medium contacted)
(1.2)	Set screw
(1.3)	Working diaphragm
(1.4)	Signal diaphragm
(1.5)	Protection diaphragm
(1.6)	Pressure plate (behind)
2	O-Ring

Pressure switch	
Pos.	Designation
17	Pressure switch

Table 14 Spare- and wearing parts

Operating instructions

12.4 Changing the diaphragm

12.4.1 General

In order to ensure a correct function of the multi-layer diaphragm pump and to fulfil the required safety and protective provisions it is absolutely necessary to check and replace the multi-layer diaphragms at regular intervals.

CAUTION ! 

Prior to replacing the diaphragm, drain the pump and, if necessary, rinse it with appropriate fluid in order to avoid contact with aggressive and/or toxic media!

CAUTION ! 

For replacing the diaphragm, the system must be depressurised!

- During maintenance or repair work, switch off the drive motor of the multi-layer diaphragm pump and secure it against inadvertent or unauthorised reactivation.
- Take appropriate protective measures: wear protective clothing, breathing mask and safety goggles. Prepare a container with appropriate fluid right beside the pump for being able to remove splashes of the pumped medium.
- Use an appropriate detergent to rinse the multi-layer diaphragm pump until no residues of the dosing medium can be detected in the pump body. Otherwise, pumped medium may leak when disassembling the pump. Collect the rinsed liquid in a safe way (avoid contact with it) and dispose of it in an environmentally compatible way. This measure is also necessary if the multi-layer diaphragm pump should be returned for repair.

12.4.2 Changing the diaphragm

The multi-layer diaphragm pump is to be replaced as complete unit.

- Set the stroke length adjustment to a stroke length of 0% (front position).
- Loosen fixing screws on the pump body
- Remove pump body and front plate (if installed) to the front.

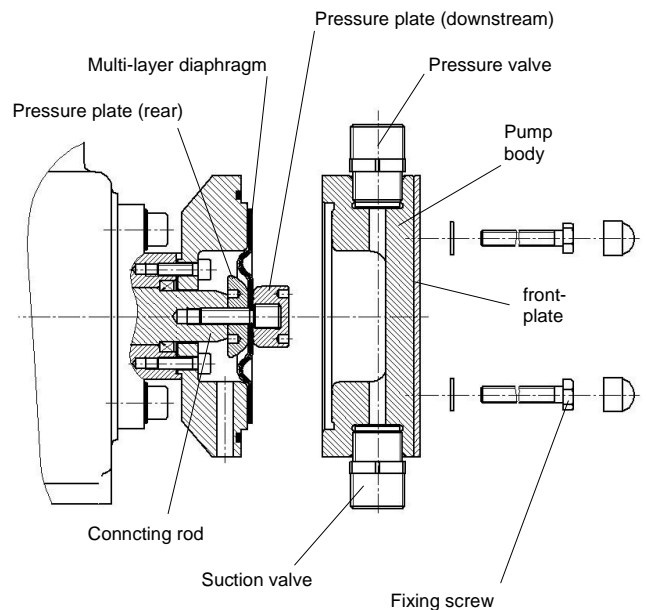

Fig. 52

- Screw the multi-layer diaphragm out of the connecting rod

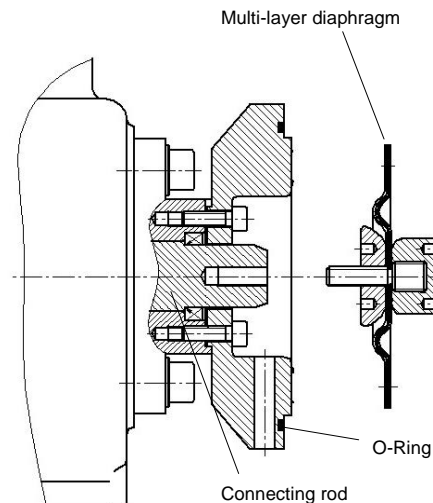

Fig. 53

- Remove O-ring
- Check signalling device visually for any sign of damage

Operating instructions

Assemble the pump in reversed order

- Insert new O-ring
- Screw new multi-layer diaphragm in the connecting rod until stop. If the holes in the diaphragm are not flush with the threaded holes in the base ring, then the diaphragm must again be screwed out until it is flush with the threaded holes.
- Set the stroke length to 50% (stroke length adjustment)
- Move diaphragm in the middle position. The middle position should be equal to a stroke length of 50%; this can for example be achieved by turning the fan blade of the motor.

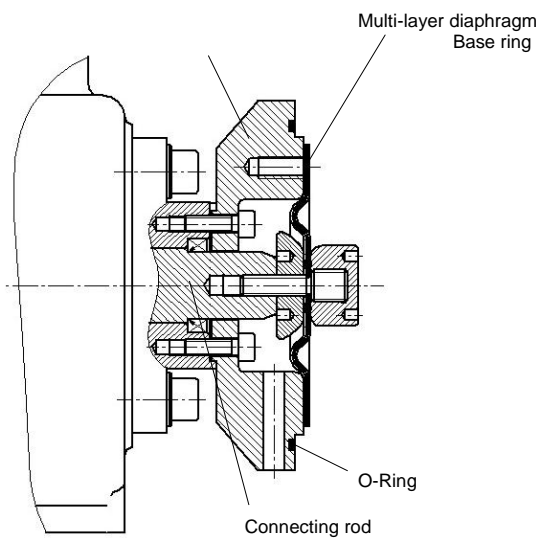

Fig. 54

- Fasten the pump body (tightening torques are mentioned in Chapter 9.1, table 06)
- When assembling the pump body, please note: suction valve below, pressure valve above!

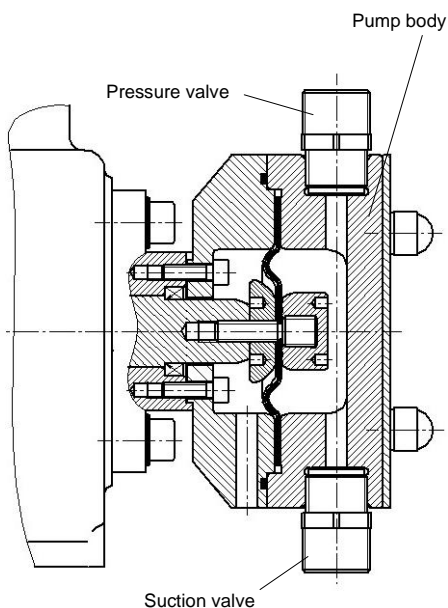

Fig. 55

- Connect the signalling devices

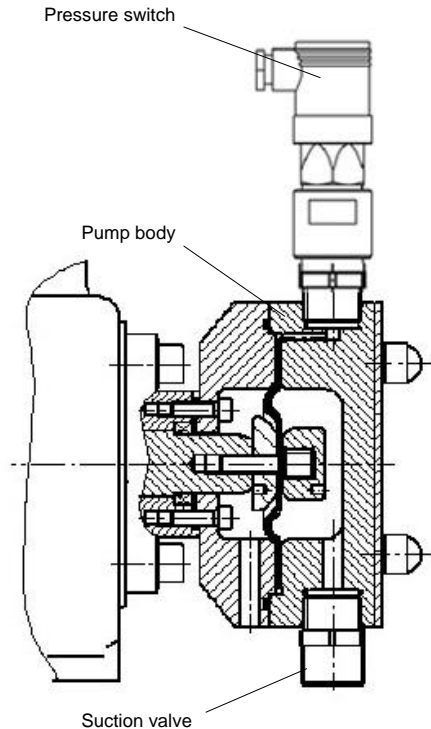

Fig. 56

Before reactivating the pump after a diaphragm replacement, remove the air between the diaphragm layers.

- Screw out the signalling device
- Let run pump for a short moment (30 seconds) with delivery pressure applied (vent)
- Switch off the pump
- Screw in signalling device

Operating instructions

12.5 Oil change

- Check oil level at regular intervals (oil sight glass).

Perform an oil change once a year.
To do so, proceed as follows:

- Unscrew the vent screw,
- Prepare an appropriate container.
Open screw plug and drain off oil.

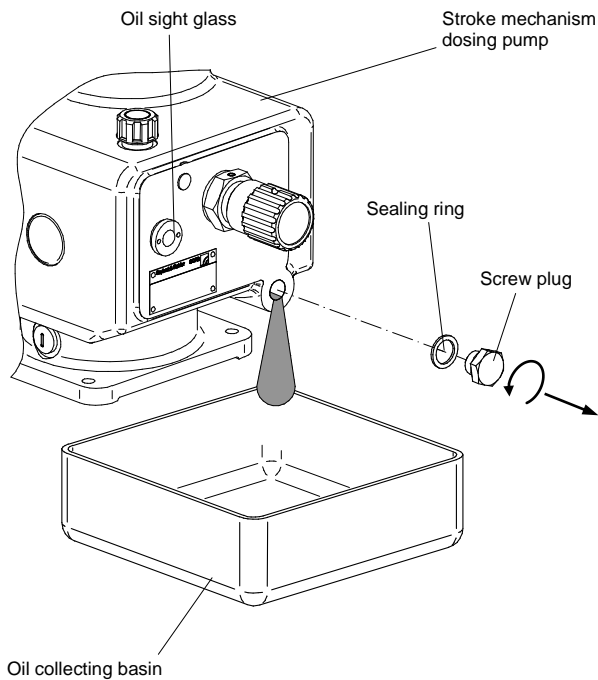

Fig. 57 Draining oil

- Anschließend Bohrung mit Verschlusschraube (auf Dichtring achten !) wieder verschließen.
- Öl in Gewindebohrung der Entlüftungsschraube einfüllen.
- Art und Menge des Getriebeöls siehe Kap. 12.1
- Entlüftungsschraube wieder eindrehen.

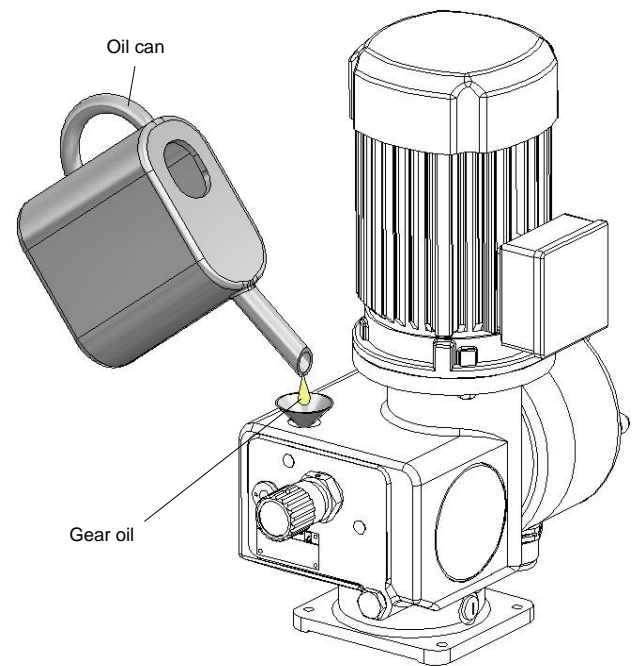

Fig. 58 Filling gear oil

13 Lubricants in stroke mechanism

Pump type	Lubricant	Quantity
410.2 – 70 ML	Gear oil SAE 90 DIN 51512	1,25 litres
410.2 – 135 ML		
410.2 – 500 ML		
410.2 – 1200 ML		

Tab. 15 Lubricant in stroke mechanism

14 Fault analysis and corrective action

sera - products are sophisticated technical products which are only shipped after having been thoroughly tested and checked at our factory. Should there be any faults, these can be detected and rectified easily and quickly if the steps in Table 16-18 are carried out.

Operating instructions

14.1 Analysis of the plain text error messages (electronics)

Error message								Possible cause	Corrective action
Analog signal < 4 mA!	Analog signal > 20 mA!	Analog signal > 25 mA!	Flow too low!	Cycle-delay memory full!	Leave the calibration range!	No stroke recognition! (internal fault)	No flow!		
●								Wire break of the analog signal line	Check analog signal line and repair, if necessary
●								The set analog signal (e.g. 4-20mA) does not match the actual analog signal (e.g. 0-20mA).	Check the set analog signal and adapt to the actual analog signal, if necessary.
●	●	●						Fault of the analog signal transmitter (sensor, controller)	Check the analog signal transmitter and eliminate fault of the transmitter if necessary
			●				●	Drive diaphragm defective	Replace drive diaphragm
			●				●	Suction height too high	Reduce suction height or suction resistance.
			●				●	Suction line leaky	Check gaskets, tighten pipe connections
			●				●	Shut-off valves in pipe closed	Open shut-off valves or check opening – check pump for damage
			●				●	Few or no conveying medium in store tank	Fill store tank
			●				●	Pump valves leaky	Remove valves and clean
			●				●	Foreign matter in pump valves or Pump valves (ball seats) damaged	Remove and clean valves, check function; replace valves if necessary.
			●				●	Pump valves incorrectly mounted or valve balls missing	Check installation position and completeness – replace missing parts or install correctly
			●				●	Filter in suction line clogged	Clean filter
			●				●	No stroke movement of the drive diaphragm	Increase stroke frequency / stroke length; check connecting rod motion.
			●				●	Counter-pressure too high	Measure pressure with manometer directly above pressure valve and compare with permissible counter-pressure
			●				●	Acceleration height too high due to pipe geometry	Check acceleration height on suction- and pressure side and compare with design data – install a pulsation damper if necessary
			●				●	Too high viscosity of the pumped medium	Check viscosity of the pumped medium and compare with the design data – reduce concentration or increase temperature if necessary
			●				●	Pumped medium outgasses in suction line and/or pump body	Check geodetic conditions and compare with the data of the pumped medium. Operate pump with suction side supply, reduce temperature of the pumped medium.
			●				●	Air in suction line while pressure applied to the pressure valve ball	Vent pressure side
			●				●	Pipe connections leaky	Tighten connection according to type of material. Be careful with plastic – risk of fracture
			●				●	Pumped medium frozen in pipe	Remove diaphragm pump and check for damage – increase temperature of the pumped medium
			●				●	Pump valves are dry	Moisten pump body and valves. Open vent valve.
				●				Frequency of the received pulses is (permanently) higher than the maximum stroke frequency of the dosing pump	Check process parameters.
				●				Pulse factor too high	Check process parameters.
					●			After calibration of the dosing pump the stroke length was adjusted by more than +/- 10%	Check the stroke length adjustment, set the set value again, calibrate again, if necessary
					●			Stroke length was set to below 15% approx., the stroke length is out of the linear dosing range.	Check the stroke length adjustment, increase the stroke length
						●		Sensory mechanism of dosing pump is defective	Contact the manufacturer

Tab. 16 Analyze and eliminate faults on the basis of the error messages – part I

Operating instructions

Error message								Possible cause	Corrective action	
System time lost!	Diaphragm rupture!	Mains voltage too g too low!	Mains voltage too high!	Pre-alarm level!	Set value not attainable! (Internal fault!)	Fault drive! (Internal fault)	Fault stroke sensor!! (Internal fault!)	Dry running of dosing pump!		
	●								Drive diaphragm defective	Replace drive diaphragm
		●	●						Electric data of the dosing pump do not match mains data	Check order data. Check electric installation.
				●				●	Few or no conveying medium in store tank	Fill store tank
					●				Only for calibrated pump: Set stroke length is too low to attain the preset set value	Check the stroke length and the set value, calibrate the pump again, if necessary.
						●			Integrated excess temperature protection (posistor) of drive motor released.	Let the temperature of the drive motor go down. Check the ambient temperature
							●		No stroke movement of the drive diaphragm	Increase stroke frequency / stroke length; check connecting rod motion.
							●		Shut-off valves in pipe closed	Open shut-off valves or check opening – check pump for damage
●									Mains voltage breakdown at operation mode „Batch-Timer“	Adjust system time

Tab. 17 Analyze and eliminate faults on the basis of the error messages – part II

Operating instructions

14.2 Analysis of other faults

Error message												Possible cause	Fault clearance	
Diaphragm pump does not draw in	Diaphragm pump does not deliver	Delivery rate is not reached	Delivery height is not reached	Delivery rate fluctuates	Maximum delivery rate exceeded	Drive motor does not start	Pipe oscillates heavily	High noise development	Low service life of the drive diaphragm	Drive is overloaded	Damage in stroke mechanism / drive	Leakage on pump head		
●	●	●											Suction height too high	Reduce suction height or suction resistance
●	●	●		●									Suction line leaky	Check gaskets, tighten pipe connections
●	●					●						●	Shut-off valves in pipe closed	Open shut-off valves or check opening – check pump for damage
●	●	●											No conveying medium in store tank	Fill store tank
●	●	●	●	●									Pump valves leaky	Remove valves and clean
●	●		●	●									Pump valves (ball seats) damaged	Remove and clean valves, check function; replace valves if necessary
●	●												Pump valves incorrectly mounted or valve balls missing	Check installation position and completeness – replace missing parts or install correctly
●	●												Filter in suction line clogged	Clean filter
						●					●		Electric data of the electronics do not match mains data	Check order data. Check electric installation.
		●	●	●		●	●	●	●	●		●	Counter-pressure too high	Measure pressure with manometer directly above pressure valve and compare with permissible counter-pressure
●	●	●	●	●									Foreign matter in pump valves	Remove and clean valves
				●	●								Pressure on suction side higher than at the end of the pressure line	Check geodetic conditions, install float valve or pressure keeping valve if necessary
		●	●	●	●	●	●	●	●	●	●	●	Acceleration height too high due to pipe geometry	Check acceleration height on suction- and pressure side with manometer and compare with design data – install a pulsation damper if necessary
									●			●	Material which is in contact with the medium not suitable for the pumped medium	Check whether the pumped medium corresponds with the design data and select other materials if necessary
●		●	●	●									Too high viscosity of the pumped medium	Check viscosity of the pumped medium and compare with the design data – reduce concentration or increase temperature if necessary
	●	●		●									Pumped medium outgasses in suction line	Check geodetic conditions and compare with the data of the pumped medium. Operate pump with suction side supply, reduce temperature of the pumped medium.
●													Air in suction line while pressure applied to the pressure valve ball	Vent pressure side
●	●	●	●	●								●	Pipe connections leaky	Tighten connection according to type of material. Be careful with plastic – risk of fracture
●	●	●										●	Temperature too low	Check flowability of the pumped medium. Temperature of pumped medium and ambient temperature must not fall below -10°C
●	●					●					●	●	Pumped medium frozen in pipe	Remove diaphragm pump and check for damage – increase temperature of the pumped medium
●	●	●	●	●					●			●	Diaphragm rupture	Replace diaphragm according to Chapter 12.4.
●	●	●		●									Air between diaphragms	remove the air between the diaphragm layers

Tab. 18 Fault analysis and corrective action

Operating instructions

15 Foreseeable misuse

The following misuse is assigned to the life cycles of the machine.

CAUTION !



Misuse can result in danger to the operating personnel!

15.1 Transport

- Tipping behavior during transport, loading and unloading ignored.
- Weight for lifting underestimated.

15.2 Assembly and installation

- Power supply not fuse protected (no fuse/fuse too large, power supply not conforming to standards).
- No or improper fastening material of the pump.
- Improper connection of the pressure pipes, wrong material i.e. PTFE tape and unsuitable connection pieces.
- Liquid pipes confused.
- Threads overturned/damaged.
- Pipes bent during connection in order to compensate for alignment errors.
- Supply voltage connected without earthed conductor.
- Socket for safe disconnection of the power supply difficult to reach.
- Mains plug cut off (direct connection), safe disconnection impossible. Safe disconnection e.g. by 2-pin main switch.
- Wrong connecting cables for supply voltage (cross-section too small, wrong insulation).
- Parts damaged (e.g. vent valve, flow meter broken off).
- Wrongly dimensioned pressure and suction pipe.
- Incorrect dimensioned and improperly fastened pump panel (panel broken off).
- Short circuit of the internal power supply (15V DC) at the control cable during installation.
- Admissible current load of the digital outputs exceeded. No **sera** sensors for flow or filling level → damage to the electronics.
- No diode for external control power supply connection → electronics overloaded/destroyed.
- Electronics opened in order to connect the mains cable directly to the power supply → electric shock or damage to the electronics.
- Connection of wrong supply voltage or mains frequency destroyed.

15.3 Start-up

- Cover on vent openings (e.g. motor).
- Suction or pressure pipes closed (i.e. foreign matters, particle size, stop valves).
- Sensor cable damaged (electronics <--> stroke mechanism), wrong or no recognition of the stroke length → wrong dosing volume and resulting process error.
- Start-up with damaged system.
- Wrong parameterization of the pump → inadvertent start. Distance between dosing pump and other dosing pumps or electrical consumers insufficient → fault by electromagnetic radiation.
- Control cables too long > 30m → malfunctions due to EMC. Control cable and power cable laid in parallel → malfunctions due to EMC.

15.4 Operation

- Fault message ignored → faulty dosing / process error.
- Pipes hit, pulsation damper not used → damage to the pipes, medium is leaking.
- Pumped medium contains particles or is contaminated.
- External fuse bridged → no cut off in case of an error.
- Ground wire removed → no cut off by fuse in case of an error, supply voltage directly at the housing.
- Insufficient lighting of the working place.
- Suction height too high, pump capacity too low → process error.

15.5 Maintenance/Repair

- Works carried out which are not described in the operating instructions (works on the stroke mechanism and the built-in pump, electronics opened).
- Prescribed maintenance schedules ignored.
- Use of wrong spare parts/oils (e.g. no **sera** original spare parts, wrong viscosity).
- Improper mounting of spare and wearing parts (e.g. wrong tightening torque for pump body).
- Oil level not checked.
- Use of cables with damaged insulation.
- No shut down / no protection against a restart before maintenance work.
- Pumped medium or utilities during an oil change insufficiently removed.
- Restart without sufficient fastening.
- Valves confused.
- Sensor pipes confused.
- Pipes not connected (e.g. suction- and pressure pipes, gas pipes).
- Gaskets damaged, medium is leaking.
- Gaskets not fitted, medium is leaking.
- Wearing of unsuitable protective clothing / no protective clothing at all.
- Operation of an uncleaned system.
- Pumped medium contaminated with oil.
- Poorly ventilated room.

Operating instructions

15.6 Cleaning

- Wrong rinsing medium (material changed, reaction with the medium).
- Wrong cleaning agent (material changed, reaction with the medium).
- Cleaning agent remains in the system (material changed, reaction with the medium).
- Protective clothing insufficient or missing.
- Use of unsuitable cleaning utensils (material changed, mechanical damage by high pressure cleaner).
- Untrained personnel.
- Vent openings clogged.
- Parts torn off.
- Sensors damaged.
- Non-observance of the safety data sheet.
- Control elements actuated.
- Poorly ventilated room.

15.7 Shut-down

- Pumped medium not completely removed.
- Disassembly of pipes with the pump running/with residual pressure.
- Disconnection of the electrical connections in a wrong sequence (ground wire first).
- Disconnection from the power supply not ensured → danger through electricity.
- Poorly ventilated room.

15.8 Disassembly

- Residues of the pumped medium and utilities in the system.
- Use of wrong disassembly tools.
- Wrong or no protective clothing at all.
- Poorly ventilated room.

15.9 Disposal

- Improper disposal of the pumped medium, utilities and materials.
- No marking of hazardous media.
- Wrong disposal of the electronics.

16 Shut-down

Switch the multi-layer diaphragm pump off.

Rinse pump head to remove the pumped medium and make sure that the detergent is suitable for the pumped medium and the material of the pump head.

17 Disposal

Shut-down system. Please see "Shut-down".

17.1 Dismantling and transport

- Remove all fluid residues, clean thoroughly, neutralize and decontaminate.
- Package unit and ship.

17.2 Complete disposal

- Remove all fluid residues from unit.
- Drain off lubricants and dispose of according to regulations!
- Dismount materials and send them to a suitable waste disposal company!

CAUTION !



The consignor is responsible for damage caused by leaking lubricants and fluids!

- Pressure switch (Type 0186)

Bedienungsanleitung	Operating instructions
Für künftige Verwendung aufbewahren	Please keep carefully for future use
<p>Membran-/ Kolbendruckschalter D Baureihe 0180 / 0181 Baureihe 0186 / 0187</p> <p>Einbau und Inbetriebnahme sind nach dieser Bedienungsanleitung und nur von autorisiertem Fachpersonal vorzunehmen</p> <p>  </p> <p></p> <p>Robert-Scheuffele GmbH & Co. KG Keplerstraße 12-14 D-74321 Bietigheim-Bissingen Telefon (07142) 597-0 Telefax (07142) 597-19 www.suco.de E-Mail: info@suco.de</p> 	<p>Diaphragm-/ Piston Pressure Switch GB Series 0180 / 0181 Series 0186 / 0187</p> <p>Installation and commissioning must be carried out in accordance with these operating Instructions and by authorized, qualified personnel only.</p> <p>  </p> <p></p> <p>Robert-Scheuffele GmbH & Co. KG Keplerstraße 12-14 D-74321 Bietigheim-Bissingen Telephone (07142) 597-0 Telecopy (07142) 597-19 www.suco.de e-mail: info@suco.de</p> 
Funktion und Anwendung	Operating and use
<p>Die Baureihe 0180 / 0181 und 0186 / 0187 öffnet oder schließt einen elektrischen Stromkreis beim Erreichen eines einstellbaren Druckwerts. Durch das Ansteigen des Drucks wird eine Membrane bzw. ein Kolben bewegt. Die Auslenkung Membrane bzw. der Hub des Kolbens hängt von der Druckkraft und der einstellbaren Federvorspannung ab. Bei einer definierten Auslenkung der Membrane bzw. einem definierten Hub des Kolbens wird ein Mikroschalter betätigt, der die elektrischen Kontakte öffnet bzw. schließt (Wechsler).</p> <p> Der Druckschalter überwacht einen eingestellten Druckwert.</p>	<p>The series 0180 / 0181 and 0186 / 0187 switch opens or closes an electrical circuit when a certain (adjustable) pressure is reached. A diaphragm or piston is moved by the increase in pressure. The amount of the diaphragm deflection or piston travel depends on the force of the pressure applied and the (adjustable) spring tension. At a predetermined deflection of the diaphragm or movement of the piston, a micro switch is actuated which opens or closes the electrical contacts (changeover).</p> <p> The pressure switch monitors a preset pressure.</p>
Vorraussetzungen für den Produkteinsatz	Conditions governing the use of the product
<p>Allgemeine, stets zu beachtende Hinweise für den ordnungsgemäßen und sicheren Einsatz des Druckschalters:</p> <p> • Halten Sie die angegebenen Grenzwerte wie z.B. Drücke, Kräfte, Momente und Temperaturen ein.</p> <p>• Berücksichtigen Sie die vorherrschenden Umgebungsbedingungen (Temperatur, Luftfeuchte, Luftdruck etc.).</p> <p>• Beachten Sie die Vorschriften der Berufsgenossenschaften, des Technischen Überwachungsvereins (TUV) oder die entsprechenden nationalen Bestimmungen.</p> <p>• Beachten Sie unbedingt die Warnungen und Hinweise in der Bedienungsanleitung.</p> <p>• Setzen Sie den Druckschalter niemals starken Stößen oder Vibrationen aus.</p> <p>• Verwenden Sie das Produkt nur im Originalzustand. Nehmen Sie keine eigenmächtige Veränderungen vor.</p> <p>• Entfernen Sie die alle Transportvorkehrungen wie Schutzfolien, Kappen oder Kartonagen.</p> <p> • Die Entsorgung der einzelnen Werkstoffe in Recycling-Sammelbehältern ist möglich.</p>	<p>The following general instructions are to be observed at all times to ensure the correct, safe use of the pressure switch:</p> <p> • Do not exceed the specified limits for e.g. pressures, forces, moments or temperatures under any circumstances.</p> <p>• Give due consideration to the prevailing ambient conditions (temperatures, atmospheric humidity, atmospheric pressure, etc.).</p> <p>• Observe the applicable safety regulations laid down by the regulatory bodies in the country of use.</p> <p>• Observe without fail the warning notices and other instructions laid down in the operating instructions.</p> <p>• Never subject pressure switch to intense blows or high vibrations.</p> <p>• Never expose the pressure switch to severe side impacts or vibrations.</p> <p>• Use the product only in its original condition. Do not carry out any unauthorized modifications.</p> <p>• Remove all items providing protection in transit such as foils, caps or cartons.</p> <p> • Disposal of the above-named materials in recycling containers is permitted.</p>

Betriebsbedingungen	Operating conditions
<p>Bei Medientemperaturen außerhalb der Raumtemperatur (20°C):</p> <p>Extreme Temperatureinflüsse (abweichend von der Raumtemperatur) können zu einer starken Schaltpunktabweichung oder zum Ausfall des Druckschalters führen</p> <p><u>Schutzart IP65:</u> Die Typenprüfung ist nicht uneingeschränkt auf alle Umweltbedingungen übertragbar.</p> <p>Die Überprüfung, ob die Steckverbindung anderen als den angegebenen Bestimmungen und Vorschriften entspricht bzw. ob diese in speziellen, von uns nicht vorgesehenen Anwendungen eingesetzt werden kann, obliegt dem Anwender.</p> <p><u>Sauerstoffeinsatz:</u> Membrandruckschalter: Beim Einsatz von Sauerstoff sind die einschlägigen Unfallverhütungsvorschriften zu beachten. Außerdem empfehlen wir, einen maximalen Betriebsdruck von 10 bar nicht zu überschreiten.</p> <p>Kolbendruckschalter: Kolbendruckschalter sind für gasförmige Medien, insbesondere für Sauerstoff nicht geeignet.</p> <p><u>Überdrucksicherheit:</u> In den Technischen Daten ist die statische Überdrucksicherheit angegeben. Sie bezieht sich auf den hydraulischen bzw. pneumatischen Teil des Druckschalters. Der dynamische Wert ist 30 bis 50 % niedriger.</p>	<p>Media temperatures other than room temperature (20°C):</p> <p>The effects of extreme temperatures (relative to the room temperature) can lead to pronounced variations in the switching point or failure of the pressure switch.</p> <p><u>Type of protection IP65:</u> Type testing does not apply to all ambient conditions without limitations. The user is responsible for verifying that the plug-and-socket connection complies with the specified rules and regulations of CE, or whether it may be used for specialized purposes other than those intended by us.</p> <p><u>Use with oxygen:</u> Diaphragm pressure switch: If oxygen is used, the applicable accident prevention regulations must be observed. In addition, we recommend a maximum operating pressure of 10 bars, which should not be exceeded.</p> <p>Piston pressure switch: Piston pressure switches are not suitable for gaseous media, particularly oxygen.</p> <p><u>Protection against overpressure:</u> The static overpressure safety is included in the technical data. The overpressure safety corresponds to the hydraulic, pneumatic part of the pressure switch. The dynamic rating of the overpressure safety is smaller than 30 to 50%.</p>

Technische Daten	Technical data																																																
<table border="1"> <thead> <tr> <th>Bemessungs- triebsspannung U_e</th> <th>Bemessungs- triebsstrom I_e</th> <th>Gebrauchs-kategorie</th> </tr> </thead> <tbody> <tr> <td>250 Volt AC 50/60 Hz</td> <td>4 Ampere</td> <td>AC12</td> </tr> <tr> <td>250 Volt AC 50/60 Hz</td> <td>1 Ampere</td> <td>AC14</td> </tr> <tr> <td>30 Volt DC</td> <td>4 / 4 Ampere</td> <td>DC12 / DC13</td> </tr> <tr> <td>50 Volt DC</td> <td>2 / 1 Ampere</td> <td>DC12 / DC13</td> </tr> <tr> <td>75 Volt DC</td> <td>1 / 0,5 Ampere</td> <td>DC12 / DC13</td> </tr> <tr> <td>125 Volt DC</td> <td>0,3 / 0,2 Ampere</td> <td>DC12 / DC13</td> </tr> <tr> <td>250 Volt DC</td> <td>0,25 / 0,2 Ampere</td> <td>DC12 / DC13</td> </tr> </tbody> </table> <p>Bemessungsisolationsspannung U_i: 300 Volt</p> <p>Bemessungsstoßspannungsfestigkeit U_{imp}: 2,5 kV</p> <p>konventioneller thermischer Strom I_{th}: 5 Ampere</p> <p>Schaltüberspannung: < 2,5 kV</p> <p>Bemessungsfrequenz: DC und 50 / 60 Hz</p> <p>Nennstrom der Kurzschlusseinrichtung: bis 5 Ampere</p> <p>Bedingter Kurzschlussstrom: < 350 Ampere</p> <p>IP-Schutzart nach EN 60 529:1991: IP65 mit Stecker</p> <p>Anzugsdrehmoment der Anschlussschrauben: < 0,35 Nm</p> <p>Anschlussquerschnitt: 0,5 bis 1,5 mm²</p> <p>Schaltdauer: < 200 min⁻¹</p> <p>Schalthysterese: 10-30%, im Werk einstellbar</p> <p>mechanische Lebensdauer: Membranausführung: 10⁶ Schaltspiele (bei Schaltdrücken bis 40 bar)</p> <p>Kolbenausführung: 10⁶ Schaltspiele</p> <p>Gehäusewerkstoff: verzinkter Stahl (Fe/Zn12cC)</p> <p>Temperaturbeständigkeit: NBR -30°C bis +100°C EPDM -30°C bis +120°C FKM -5°C bis +120°C</p> <p><u>Überdrucksicherheit:</u> Membrandruckschalter: 100 bar (0,3...1,5 bar, 1...10 bar) 300 bar (1...10 bar m. Endnummer 040, 041, 042, 340, 341, 342 und restliche Druckbereiche)</p> <p>Kolbendruckschalter: 600 bar</p>	Bemessungs- triebsspannung U _e	Bemessungs- triebsstrom I _e	Gebrauchs-kategorie	250 Volt AC 50/60 Hz	4 Ampere	AC12	250 Volt AC 50/60 Hz	1 Ampere	AC14	30 Volt DC	4 / 4 Ampere	DC12 / DC13	50 Volt DC	2 / 1 Ampere	DC12 / DC13	75 Volt DC	1 / 0,5 Ampere	DC12 / DC13	125 Volt DC	0,3 / 0,2 Ampere	DC12 / DC13	250 Volt DC	0,25 / 0,2 Ampere	DC12 / DC13	<table border="1"> <thead> <tr> <th>Rated operating voltage U_e</th> <th>Rated operating current I_e</th> <th>Utilization category</th> </tr> </thead> <tbody> <tr> <td>250 Volt AC 50/60 Hz</td> <td>4 Amps</td> <td>AC12</td> </tr> <tr> <td>250 Volt AC 50/60 Hz</td> <td>1 Amp</td> <td>AC14</td> </tr> <tr> <td>30 Volt DC</td> <td>4 / 4 Amps</td> <td>DC12 / DC13</td> </tr> <tr> <td>50 Volt DC</td> <td>2 / 1 Amp</td> <td>DC12 / DC13</td> </tr> <tr> <td>75 Volt DC</td> <td>1 / 0,5 Amp</td> <td>DC12 / DC13</td> </tr> <tr> <td>125 Volt DC</td> <td>0,3 / 0,2 Amp</td> <td>DC12 / DC13</td> </tr> <tr> <td>250 Volt DC</td> <td>0,25 / 0,2 Amp</td> <td>DC12 / DC13</td> </tr> </tbody> </table> <p>Rated insulation voltage U_i: 300 volts</p> <p>Rated surge capacity U_{imp}: 2,5 kV</p> <p>Rated thermal current I_{th}: 5 Amps</p> <p>Switching over voltage: < 2,5 kV</p> <p>Rated frequency: DC and 50 / 60 Hz</p> <p>Rated current of short-circuit protective device: Up to 5 Amps</p> <p>Rated short-circuit current: < 350 Amps</p> <p>IP protection to EN 60 529:1991: IP65 with plug</p> <p>Tightening torque for terminal screws: < 0,35 Nm</p> <p>Connection size: 0,5 to 1,5 mm²</p> <p>Operating frequency: < 200 per min⁻¹</p> <p>Switching hysteresis: 10-30% adjustable by the factory</p> <p>mechanical life: Diaphragm type: 10⁶ operation cycles (at trip pressure up to 40 bars)</p> <p>Piston type: 10⁶ operation cycles</p> <p>Body material: Zic plated steel (Fe/Zn12cC)</p> <p>Temperature range: NBR -30°C to +100°C EPDM -30°C to +120°C FKM -5°C to +120°C</p> <p><u>Over pressure safety:</u> Diaphragm pressure switch: 100 bars (0,3 to 1,5 bar, 1 to 10 bar) 300 bars (1 to 10 with end number 040, 041, 042, 340, 341, 342 and residual pressure range)</p> <p>Piston pressure switch: 600 bars</p>	Rated operating voltage U _e	Rated operating current I _e	Utilization category	250 Volt AC 50/60 Hz	4 Amps	AC12	250 Volt AC 50/60 Hz	1 Amp	AC14	30 Volt DC	4 / 4 Amps	DC12 / DC13	50 Volt DC	2 / 1 Amp	DC12 / DC13	75 Volt DC	1 / 0,5 Amp	DC12 / DC13	125 Volt DC	0,3 / 0,2 Amp	DC12 / DC13	250 Volt DC	0,25 / 0,2 Amp	DC12 / DC13
Bemessungs- triebsspannung U _e	Bemessungs- triebsstrom I _e	Gebrauchs-kategorie																																															
250 Volt AC 50/60 Hz	4 Ampere	AC12																																															
250 Volt AC 50/60 Hz	1 Ampere	AC14																																															
30 Volt DC	4 / 4 Ampere	DC12 / DC13																																															
50 Volt DC	2 / 1 Ampere	DC12 / DC13																																															
75 Volt DC	1 / 0,5 Ampere	DC12 / DC13																																															
125 Volt DC	0,3 / 0,2 Ampere	DC12 / DC13																																															
250 Volt DC	0,25 / 0,2 Ampere	DC12 / DC13																																															
Rated operating voltage U _e	Rated operating current I _e	Utilization category																																															
250 Volt AC 50/60 Hz	4 Amps	AC12																																															
250 Volt AC 50/60 Hz	1 Amp	AC14																																															
30 Volt DC	4 / 4 Amps	DC12 / DC13																																															
50 Volt DC	2 / 1 Amp	DC12 / DC13																																															
75 Volt DC	1 / 0,5 Amp	DC12 / DC13																																															
125 Volt DC	0,3 / 0,2 Amp	DC12 / DC13																																															
250 Volt DC	0,25 / 0,2 Amp	DC12 / DC13																																															

Bedienteile und Anschlüsse

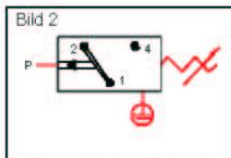
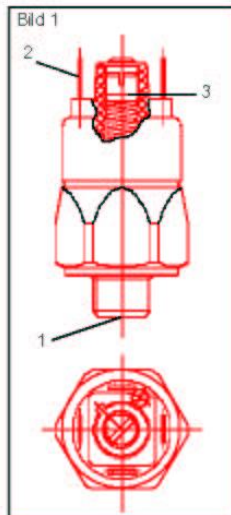

- (1) Hydraulischer / Pneumatischer Anschluss
- (2) Elektrischer Anschluss (AMP 6,3x0,8)
- (3) Einstellschraube für den Schaltpunkt

Operating controls and connections

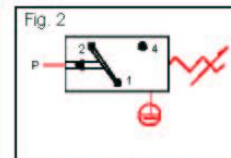
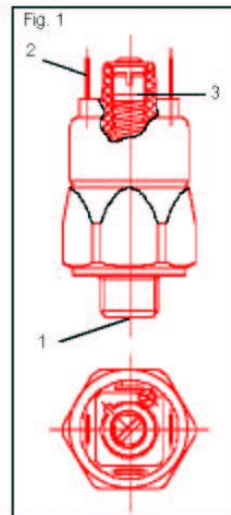

- (1) Hydraulic / Pneumatic connection
- (2) Electrical connection (AMP 6,3x0,8)
- (3) Switching point adjusting screw

Einbau

Mechanisch, pneumatisch, hydraulisch:

Drehen Sie den Druckschalter an dem sechskantförmigen Ansatz mit einem Maulschlüssel der Schlüsselweite 27 (nach DIN 894 o.ä.) in den vorgesehenen Druckanschluss (Anzugsdrehmomente siehe nachfolgende Tabelle).

➔ Zum Abdichten des Systems verwenden Sie einen Standard-Kupferdichtung mit den entsprechenden Abmessungen.

Anschlussgewinde	Drehmoment
M10x1keg. und NPT1/8*	Einschrauben bis System abgedichtet ist
M10x1zyl.	35 Nm
Restliche	50 Nm

Elektrisch:

Verkabeln Sie den Druckschalter gemäß dem Schaltbild (Bild 2).

➔ Verwenden Sie die Gerätesteckdose 1-1-80-652-002 (nicht im Lieferumfang enthalten!).

Installation

Mechanical / pneumatic / hydraulic:

With a size 27 open-ended wrench (to DIN 894 or similar), install the pressure switch, by means of the hexagon connector, in the corresponding pressure socket (tightening torque G1/4": 50 Nm).









➔ For sealing the system use a standard copper gasket of the appropriate dimensions.

Connecting thread	Torque
M10x1keg. and NPT1/8*	Tighten until system is hermetically sealed
M10x1 straight	35 Nm
Others	50 Nm

Electrical:

Connect up the pressure switch in accordance with the cruit diagram (Fig. 2).

➔ Use a connector type 1-1-80-652-002 (not include in the delivery specification).

<p>Inbetriebnahme</p> <ol style="list-style-type: none"> 1. Verkabeln Sie die elektrischen Anschlüsse 1 und 4 mit einem Durchgangsprüfer (Bild 2). 2. Drehen Sie die Einstellschraube (3) zunächst ganz ein. Verwenden Sie zum Einstellen des Druckschalters einen Schraubendreher mit 6,3 mm Klingenbreite. 3. Beachten Sie bitte, dass die Einstellschraube (3) nur beim Eindrehen einen Anschlag besitzt. 4. Drehen Sie die Einstellschraube (3) so weit heraus, bis der Druckschalter umschaltet (Durchgangsprüfer reagiert). 5. Korrigieren Sie gegebenenfalls den Schaltdruck durch Verdrehen der Einstellschraube (3). <p>Bei der Inbetriebnahme des Druckschalters beachten Sie bitte die entsprechenden Sicherheitsvorschriften der Berufsgenossenschaften oder die entsprechenden nationalen Bestimmungen.</p> <p>Die Einstellung der Hysterese ist nur werkseitig durchführbar. Bei unsachgemäßer Vorgehensweise kann der Druckschalter beschädigt werden.</p>	<p>Entry into service</p> <ol style="list-style-type: none"> 1. Using a continuity tester, wire up the electrical connections 1 and 4 (Fig. 2). 2. First, screw in the adjusting screw (3) as far as it will go. To adjust the pressure switch use a screwdriver with a 6,3 mm wide blade. 3. Adjust the pressure switch to the desired actuating pressure (a test pressure gauge is required). 4. Ease off the adjusting screw (3) to a sufficient extent to cause the pressure switch to trip (continuity tester reacts). 5. If necessary, adjust the trip pressure setting by turning the adjusting screw (3). <p>When putting the pressure switch into service, please observe the applicable safety regulations laid down by the governing bodies in the country of use.</p> <p>The adjustment of Hysteresis can only be carried out in the factory. If this is inexpertly undertaken, damage may be caused to the pressure switch.</p>
<p>Ausbau</p> <p>Beachten Sie folgende wichtige Punkte beim Ausbau des Druckschalters:</p> <ul style="list-style-type: none"> • Das Drucksystem, aus dem der Druckschalter ausgebaut werden soll, muss sich in drucklosem Zustand befinden. • Es müssen alle relevanten Sicherheitsbestimmungen beachtet werden. • Drehen Sie den Druckschalter mit einem Maulschlüssel der Schlüsselweite 27 (nach DIN 894 o.ä.) aus dem Druckanschluss. 	<p>Removing the pressure switch</p> <p>When removing the pressure switch, observe the following important instructions:</p> <ul style="list-style-type: none"> • The pressurized system from which the pressure switch is intended to be removed must be entirely of pressure. • All the relevant safety regulations must be observed. • Use a size 27 open-ended wrench (to DIN 894 or similar), to remove the pressure switch.
<p>Zeichenerklärung</p> <p> Achtung  Hinweis, Bemerkung  Recycling  Gefahr</p>	<p>Key to drawings:</p> <p> Caution  Note  Recycling  Danger</p>
<p>Art.-Nr.: 1-1-80-628-014_2 06 / 02</p>	<p>Art.-No.: 1-1-80-628-014_2 06 / 02</p>

**Controllable
Multi layer diaphragm pump**
Series C 410.2 ML



Operating instructions

Notes:

**Controllable
Multi layer diaphragm pump**
Series C 410.2 ML



Operating instructions

Notes

