

ZX 411.3 - serie

robust, durable, versatile, economic...

sera - diaphragm pumps

of series ZXM 411.3 and ZXRI 411.3 are oscillating displacement pumps for delivery and dosing and feeding liquids in a variety of industries. Performance range between 2200 l/h and 3100 l/h, pressures up to max. 4 bar.

Application

Liquid chemicals with aggressive, odorous, abrasive, radioactive, flammable, viscous or toxic properties.

...further features of performance

- high dosing accuracy
- long service life of diaphragms*
- high-quality materials
- linear control characteristic (ZXRI series)
- low maintenance
- low operating expenses
- leakage-free
- unlimitedly to run dry
- easy to operate
- designs according to ATEX
- great suction heights

* compared to common conventional diaphragms

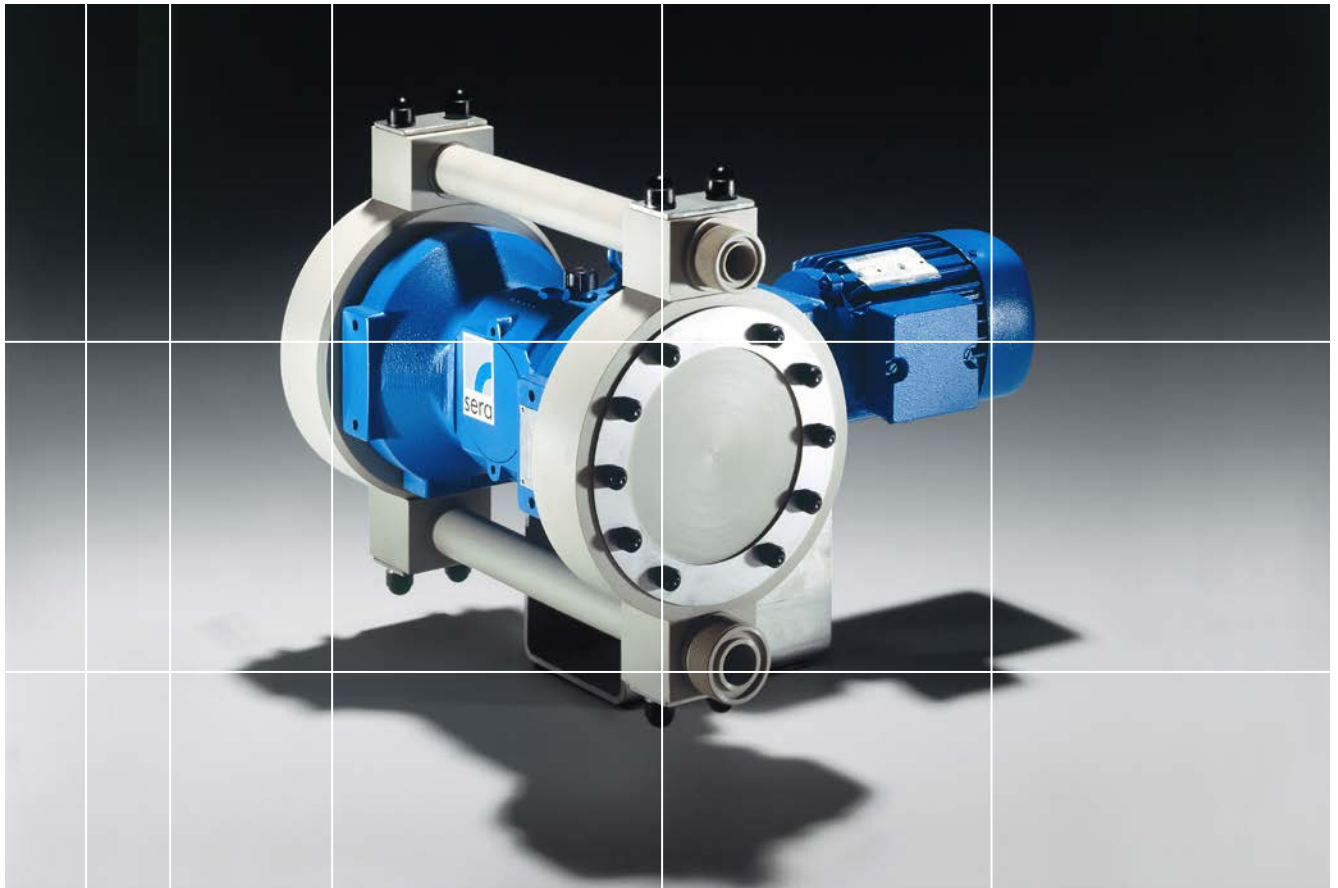

Design options

The pump has two heads – technical data according to the performance schedule.
The capacity of the ZXRI - type series can be set manually at the integrated frequency converter.
The ZXM-types run with constant stroke frequency. Therefore the capacity cannot be set. In ZXRF design they can be controlled via an external frequency converter so that their capacity can be adjusted to the process conditions again.

Single diaphragm pump *

The mechanically coupled working diaphragm acts directly upon the chemical.

* Double diaphragm design on request

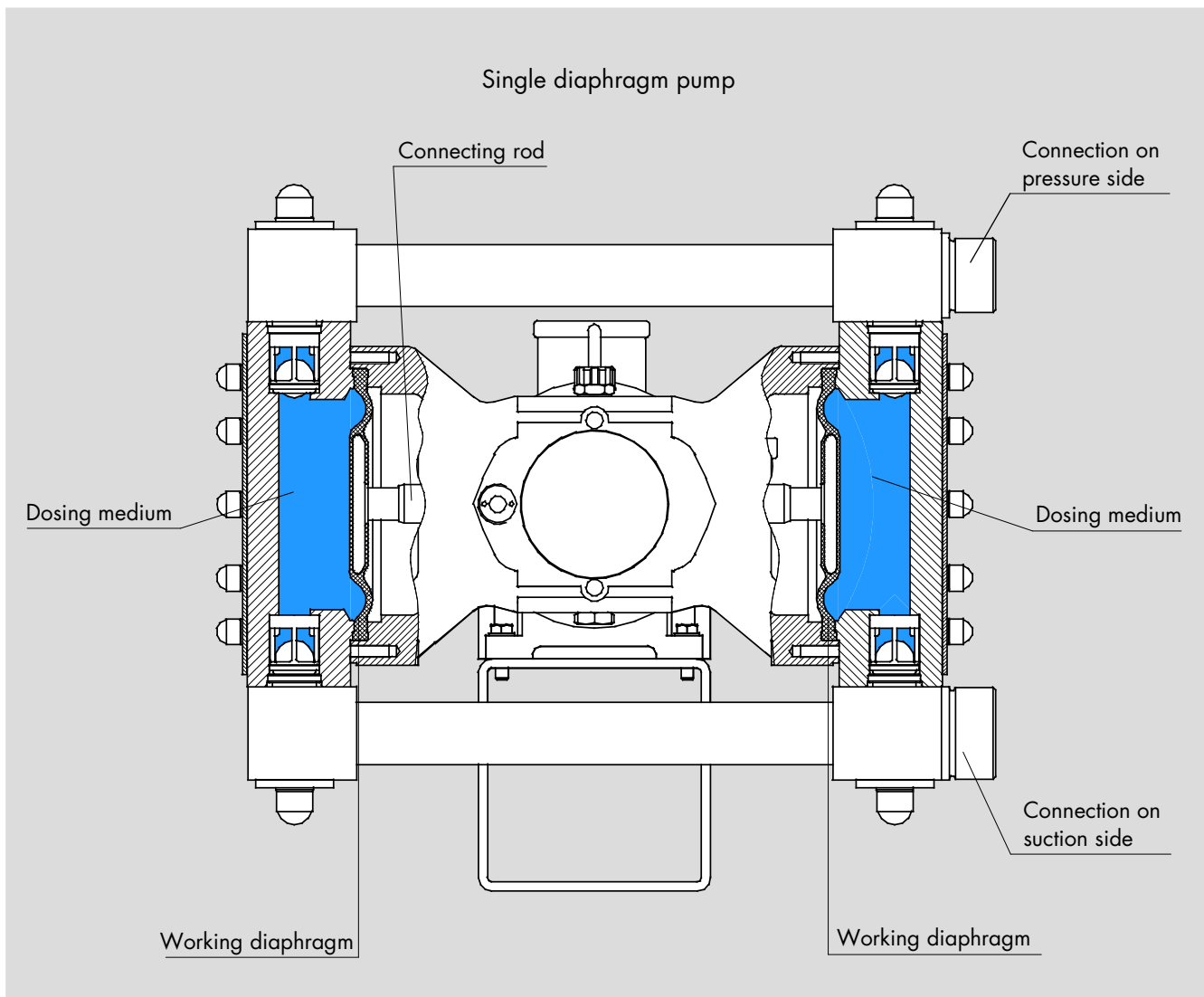

Technical Data

Serie ZXM 411.3

Pump type	Nominal capacity		Max. counter-pressure p_2 max. [bar]	Max. suction height [mWS]	Inlet size DN [mm]	Outlet size DN [mm]	Nominal stroke frequency		Driving power (motor) P_M [kW]
	Q_N 50 Hz [l/h]	Q_N 60 Hz [l/h]					n_N 50 Hz [min ⁻¹]	n_N 60 Hz [min ⁻¹]	
ZXM 411.3 – 2200 e	2200	2640	4	8	32	25	92	110	0,75
ZXM 411.3 – 2600 e	2600	3120	4	8	32	25	103	123	0,75
ZXM 411.3 – 3100 e	3100	¹⁾	4	8	32	25	128	–	0,75

¹⁾ with 60 Hz type ZXM 411.3 - 2600e is to be used

Serie ZXRI 411.3

Pump type	Nominal capacity Q_N 50 / 60 Hz [l/h]	Max. counter-pressure p_2 max. [bar]	Max. suction height [mWS]	Inlet size DN [mm]	Outlet size DN [mm]	Nominal stroke frequency n_N 50 / 60 Hz [min ⁻¹]	Driving power (motor) P_M [kW]
ZXRI 411.3 – 2600 e	230 – 2600	4	8	32	25	110	0,75
ZXRI 411.3 – 3100 e	230 – 3100	4	8	32	25	123	0,75

