

Operating Instructions

Product: Diaphragm pump

Type: ZXM... ZXRI... ZXRf...

... 411.3 – 2200 (e)

... 411.3 – 2600 (e)

... 411.3 – 3100 (e)

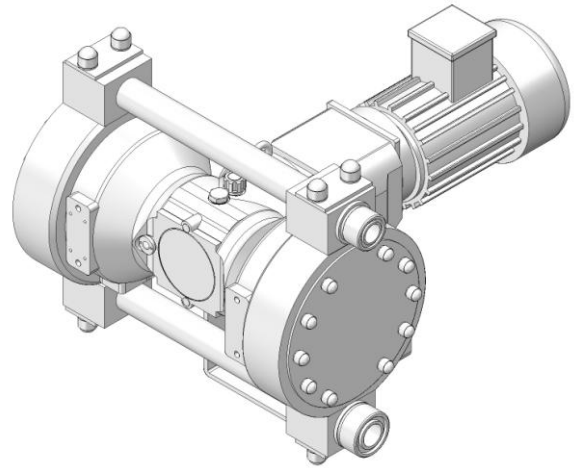

Please state here the exact type and serial number of your pump.
(can be read off the type plate on the pump)

Type:

Serial No.:

These data are important in case of queries or for ordering spare and wearing parts and must absolutely be stated.

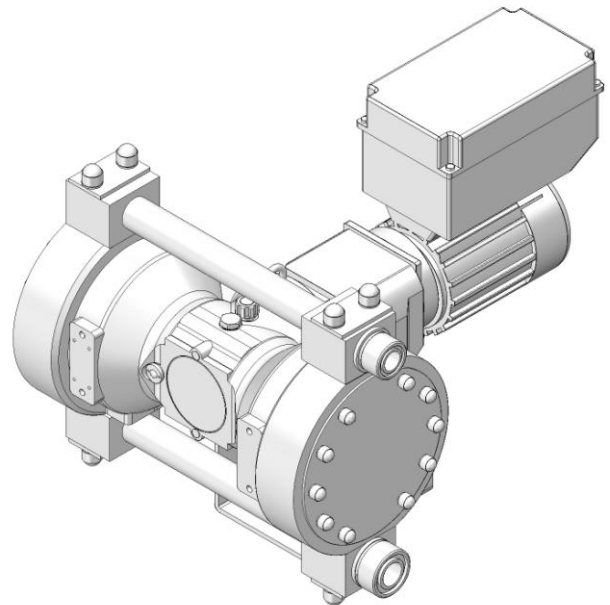

Manufacturer:

**Seybert & Rahier
GmbH + Co. Betriebs-KG**
sera-Straße 1
34376 Immenhausen
Germany
Tel. +49 5673 999-00
Fax. +49 5673 999-01
www.sera-web.com
info@sera-web.com

CAUTION !



Keep the operating instructions for future application!

Operating Instructions

Table of contents:

1	General.....	4	6	Technical specifications.....	10
2	Types.....	4	6.1	Dimensions, plastic design.....	10
2.1	Type code.....	4	6.2	Dimensions, special steel design.....	12
2.2	Type plate.....	4	6.3	Performance data.....	14
2.3	Materials.....	5	6.4	Motor data.....	14
2.4	Viscosity, pumped medium.....	5	7	Functional description.....	15
2.5	Dosing range.....	5	7.1	General.....	15
2.6	Noise measurement.....	5	7.2	Components of the diaphragm pump ZYM 409.1... 15	
3	Safety instructions.....	5	7.2.1	Stroke mechanism.....	15
3.1	Note on quality.....	5	7.2.2	Pump body.....	16
3.2	Marking of notes.....	5	7.2.3	Suction/pressure valve.....	16
3.2.1	Marking of notes in these operating instructions.....	5	7.2.4	Stroke frequency transmitter (option).....	17
3.2.2	Marking of notes on the product.....	5	7.2.5	Diaphragm rupture monitoring device (option).....	17
3.3	Personnel qualification and training.....	5	7.3	Drive motor.....	18
3.4	Dangers in case of inobservance of the safety instructions.....	5	7.3.1	Motor connection (standard).....	18
3.5	Safety conscious working.....	6	7.3.2	Direction of rotation.....	18
3.6	Safety instructions for the owner / operator.....	6	7.3.3	Terminal box.....	18
3.7	Safety instructions for maintenance-, inspection and installation work.....	6	7.3.4	Start-up.....	18
3.8	Arbitrary modification and spare parts production ...	6	7.3.5	Motor protection.....	18
3.9	Improper operations.....	6	7.3.6	Maintenance of the drive motor.....	18
3.10	Intended use.....	6	7.3.7	Restart.....	18
3.11	Personal protection for maintenance and service....	6	8	Assembly / Installation.....	19
3.12	Utilities.....	6	8.1	Installation instructions.....	19
4	Transport and intermediate storage.....	7	8.1.1	Provide overpressure protection.....	20
4.1	General.....	7	8.1.2	Prevent a backflow of the pumped medium.....	21
4.2	Transport.....	7	8.1.3	Eliminate undesired siphoning.....	21
4.3	Storage.....	7	8.1.4	Install the empty-tank alarm.....	22
5	Components of the diaphragm pump.....	8	8.1.5	How to avoid an emptying of the suction line.....	22
5.1	Single diaphragm pump.....	8	8.1.6	Line strainer.....	23
5.2	Double diaphragm pump.....	9	8.1.7	Suction via a siphon pipe.....	23
			8.1.8	In case of slightly degassing dosing media.....	24
			8.1.9	Dosing of suspensions.....	24
			8.1.10	Damping of the pulsation.....	24
			9	Peration in explosion-hazardous areas.....	26
			9.1	General.....	26
			9.2	Identification.....	26
			9.3	Installation.....	26
			9.3.1	General.....	26
			9.3.2	Working in explosion-hazardous areas.....	26
			9.4	Potential equalisation.....	26
			9.5	Start-up.....	26
			9.6	Operation.....	26
			9.6.1	General.....	26
			9.6.2	Degassing of the pumped medium.....	26
			9.6.3	Temperature indications.....	26
			9.7	Maintenance.....	26

Operating Instructions

10	Maintenance	27
10.1	Wearing parts	27
10.2	Spare parts	27
10.3	Spare and wearing parts	28
10.3.1	(PP-FRP/PP, PVDF-FRP/PVDF)	28
10.3.2	(PVC-U)	30
10.3.3	(stainless steel)	32
10.4	Changing the Diaphragm	34
10.4.1	General	34
10.4.2	Single diaphragm pump	34
10.4.3	Double diaphragm pump	36
10.5	Oil change	37
11	Lubricants	38
11.1	Lubricant in the stroke mechanism	38
11.2	Buffer fluid	38
12	Fault analysis and corrective action	38
13	Foreseeable misuse	40
13.1	Transport	40
13.2	Assembly and installation	40
13.3	Start-up	40
13.4	Operation	40
13.5	Maintenance/Repair	40
13.6	Cleaning	41
13.7	Shut-down	41
13.8	Disassembly	41
13.9	Disposal	41
14	Shut-down	41
15	Disposal	41
15.1	Dismantling and transport	41
15.2	Complete disposal	41

Operating Instructions

1 General

Before commissioning and during operation of the **sera** – diaphragm pump the respective regulations valid at the place of installation are to be observed.

The **sera** – diaphragm pump is delivered ready for installation. Carefully read these instructions and especially the safety instructions herein contained before installation and initial start-up of the pump.

2 Types

2.1 Type code

Example:

Diaphragm pump type **ZXM 411.3 – 2200 e**

Z	X	M	411.3	2200	e
----------	----------	----------	-------	------	---

Pump control

- Z** Twin design (stroke mechanism with 2 pump bodies)
- X** Stroke mechanism with 2 opposite pump heads, suction and pressure side brought together
- M** not controlled
- RF** Drive suitable for frequency converter operation
- RI** Drive with integrated frequency converter and potentiometer to adjust the stroke frequency manually

ZXM	411.3	2200	e
------------	-------	------	---

Indication of model range/stroke mechanism

ZXM	411.3	2200	e
------------	-------	------	---

Indication of nominal delivery rate

This number states the nominal delivery rate in litres/hour. (standard version referring to water)

ZXM	411.3	2200	e
------------	-------	------	---

Indication of the pump design

- e** single diaphragm pump
- without* double diaphragm pump

2.2 Type plate

Each **sera** diaphragm pump is factory provided with a type plate. The following information can be found on this type plate.

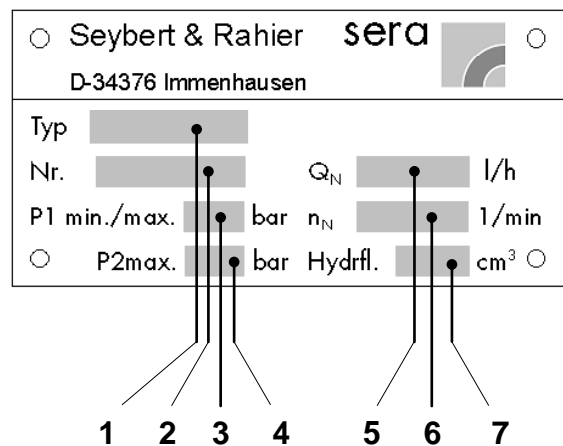

Fig. 01 Type plate

Explanation of the indications on the type plate		
1	Type	Pump type
2	No.	Serial number of the pump
3	P ₁ min/max [bar]	Minimum/maximum permissible pressure in the pump inlet Minimum/maximum permissible pressure in the inlet cross section which the pump can be used for. Please consider that pressure depends on rotation speed, delivery rate, temperature and static pressure at the inlet.
4	P ₂ max [bar]	Maximum permissible pressure in the pump outlet Maximum permissible pressure in the outlet cross section which the pump can be used for. Please consider that pressure depends on rotation speed, delivery rate, temperature and static pressure at the outlet.
5	Q _N l/h	Nominal delivery rate Delivery rate which the pump was ordered for, based on the nominal rotation speed n _N , the nominal delivery height p ₂ max. and the delivery medium stated in the supply contract.
6	n _N 1/min	Nominal stroke frequency Stroke frequency which the pump has been designed for
7	Hydraulic fluid [cm ³]	Buffer fluid Quantity of buffer fluid in the diaphragm ring (in the case of double diaphragm pumps)

Table 01 Explanation of type plate

Operating Instructions

2.3 Materials

The materials used are stated in the order confirmation and the product description.

2.4 Viscosity, pumped medium

The diaphragm pump is suitable for fluids with viscosities < 100 mPas.

2.5 Dosing range

The flow capacity of the diaphragm pump can be adjusted only with the ZXRI- and ZXRF-model via a built-on or external frequency converter. The flow capacity of the ZXM is constant.

2.6 Noise measurement

According to DIN 45635 the sound pressure level measured of the diaphragm pumps is between 60 and 70 dB (A).

3 Safety instructions

CAUTION !



The notes in Chapter 9 are to be observed if the pump is operated in explosion-hazardous areas.

3.1 Note on quality

Observance of these operating instructions and, in particular, the safety instructions, helps to

- avoid dangers to persons, machines, and environment
- increase the reliability and service life of the pump and the entire system
- reduce repair cost and downtime.

The **sera** quality management and quality assurance system for pumps, systems, fittings, and compressors is certified according to DIN EN ISO 9001:2000.

The **sera** – diaphragm pump complies with the valid safety requirements and accident prevention regulations.

CAUTION !



Always keep these operating instructions within reach at the place of installation of the pump.

CAUTION !



Pay attention to the safety data sheet of the pumped medium! The owner must take corresponding accident prevention measures to protect operating personnel from danger through the pumped media used!

3.2 Marking of notes

3.2.1 Marking of notes in these operating instructions

Special notes in these operating instructions are marked with the general danger symbol



(safety symbol in compliance with DIN 4844 – W9)

The safety sign appears in the following cases:

- If improper observance or non-observance of the operating manual, work instructions, specified operating procedures and similar can lead to personal injury or accidents.
- If improper observance or non-observance of the operating manual, work instructions, specified operating procedures and similar can lead to damage to property.
- Due to danger of causticization personnel must wear protective clothing (safety goggles, safety gloves and safety apron) for maintenance and repair work on parts which come into contact with hazardous products or for changing the containers.

3.2.2 Marking of notes on the product

Symbols which are directly attached to the pump, e.g. arrows for direction of rotation or symbols for fluid connections are to be observed and kept in legible condition.

3.3 Personnel qualification and training

The personnel who operate, maintain, inspect and install the diaphragm pump must be suitably qualified. Range of responsibility, and supervision of the personnel are to be clearly defined by the owner. If the personnel do not have the knowledge required it is to be trained and instructed accordingly. If required such a training can be carried out by the manufacturer /supplier upon order of the owner. The owner must also ensure that the personnel have understood the operating instructions.

3.4 Dangers in case of inobservance of the safety instructions

Inobservance of these safety instructions can result in danger to persons, hazards to the environment and damage to the pump.

Inobservance can result in:

- Failure of important functions of the pump/system
- Inobservance of prescribed methods for maintenance and servicing
- Danger to persons through electrical, mechanical and chemical influences
- Hazards to the environment through leaking dangerous media

Operating Instructions

3.5 Safety conscious working

The safety instructions specified in this operating manual, the national regulations for accident prevention, the safety regulations for the pumped medium valid at the place of installation as well as internal working-, operating-, and safety instructions of the owner are to be observed.

3.6 Safety instructions for the owner / operator

Leaking pumped media and utilities must be disposed off in such a way that any danger to persons and hazards to the environment are excluded. The legal regulations are to be observed.

Dangers through electrical energy are to be precluded.

3.7 Safety instructions for maintenance-, inspection and installation work

The owner must ensure that all maintenance-, inspection- and installation work are exclusively carried out by authorized and qualified personnel who have read the operating instructions carefully.

The spare parts and utilities used must comply with the requirements of the respective operating instructions.

All screwed connections and connections may only be removed when the system is not under pressure.

3.8 Arbitrary modification and spare parts production

Modification to and changement of the pump is only permitted after previous agreement of the manufacturer. Original spare parts and accessories approved by the manufacturer increase safety.

CAUTION !



If non-approved parts are used or if the pump (e.g. drive motors) is modified arbitrarily the manufacturer refuses any liability claims.

3.9 Improper operations

Operating safety of the supplied diaphragm pump is only guaranteed if the product is used as intended, according to the descriptions in Chapter 3.10 of these operating instructions.

3.10 Intended use

The **sera** – diaphragm pump is only to be deployed according to the intended purpose stated in the product description and the acceptance test certificate.

If the diaphragm pump is to be used for other applications, then the suitability of the pump for the new operating conditions must be discussed with **sera** beforehand!

Criteria for the proper use of the diaphragm pump are:

- Observe characteristics of the pumped medium (please see safety- and product data sheet of the pumped medium used – the safety data sheet is to be provided by the supplier / owner of the pumped medium)
- Resistance of the materials which come into contact with the pumped medium
- Operating conditions at the place of installation
- Pressure and temperature of the pumped medium
- Voltage supply

3.11 Personal protection for maintenance and service

In order to avoid risks to health, the provisions of the German Ordinance on Hazardous Substances (GefStoffV) (§14 Safety Data Sheet) and relevant national safety regulations for the pumped medium must strictly be adhered to.

In case of an incident pay attention to the following leaking media:

- fluids
- vapours
- noise emissions (sound level)

Emissions are to be monitored by corresponding monitoring systems.

CAUTION !



Wear protective clothing, gloves, and a face protecting and breathing mask.

CAUTION !



Personal protective equipment must be provided by the owner!

3.12 Utilities

If not agreed otherwise in the contract conditions, the **sera** diaphragm pump will always be supplied with the necessary utilities.

(For type and quantity of utilities/lubricants, see Chapter 11)

Operating Instructions

4 Transport and intermediate storage

4.1 General

Before shipment **sera** - products are checked for proper condition and functioning.

The customer has to check the product for transport damage immediately after receipt. Any damage detected is to be reported immediately to the carrier and the supplier.

CAUTION !

The packaging material must be disposed of appropriately!



4.2 Transport

Select a hoist which is adapted to the weight of the pump and attach it to the motor flange and lifting screw of the pump (see Fig. 02).

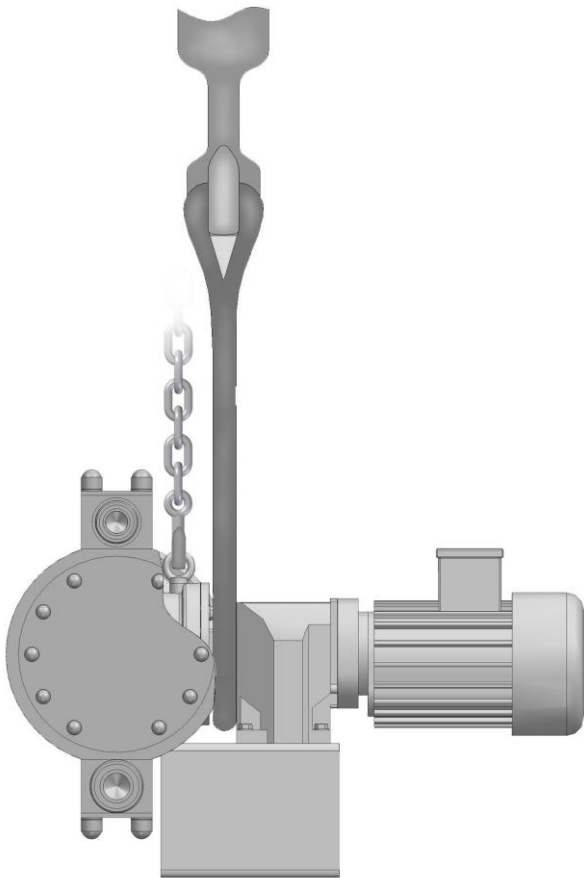

Fig. 02 Transport/handling

4.3 Storage

An undamaged packaging protects the unit during subsequent storage and should only be opened when the diaphragm pump is installed.

Proper storage increases the service life of the diaphragm pump and comprises prevention of negative influences such as heat, humidity, dust, chemicals etc.

The following storage instructions are to be observed:

- Storage place: cool, dry, dust-free and slightly ventilated
- Storage temperatures between +2°C and +40°C
- Relative air humidity not more than 50%.
- The maximum storage time for the standard system is 12 months.

If these values are exceeded, metal products should be sealed in foil and protected from condensation water with a suitable desiccant.

Do not store solvents, fuels, lubricants, chemicals, acids, disinfectants and similar in the storage room.

Operating Instructions

5 Components of the diaphragm pump

5.1 Single diaphragm pump

The diaphragm pump may be composed of the following (main) components:

- Stroke mechanism with drive
- Pump bodies
- Valves

Optional accessories:

- Diaphragm rupture electrodes MBE-02
- Stroke frequency transmitter

not depicted:

- Drive motor for frequency converter operation (ZXRf 411.3 ...)
- EExellT4 - motor

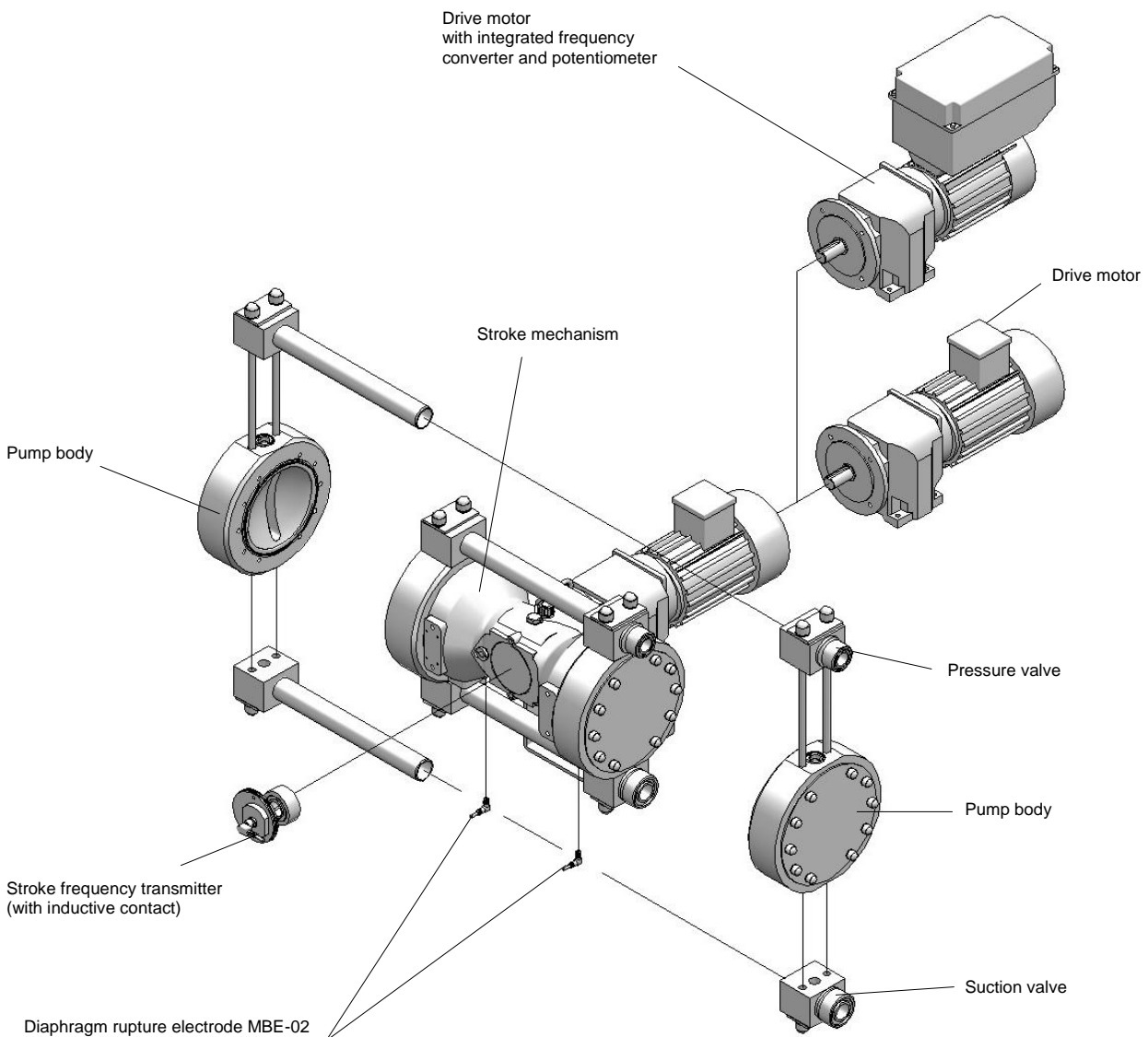

Fig. 03 Overview of the components

Operating Instructions

5.2 Double diaphragm pump

The double diaphragm pump may be composed of the following (main) components:

- Stroke mechanism with drive
- Pump bodies
- Valves

Optional accessories:

- Diaphragm rupture electrodes MBE-04
- Stroke frequency transmitter

not depicted:

- Drive motor for frequency converter operation (ZXRf 411.3 ...)
- EExellT4 - motor

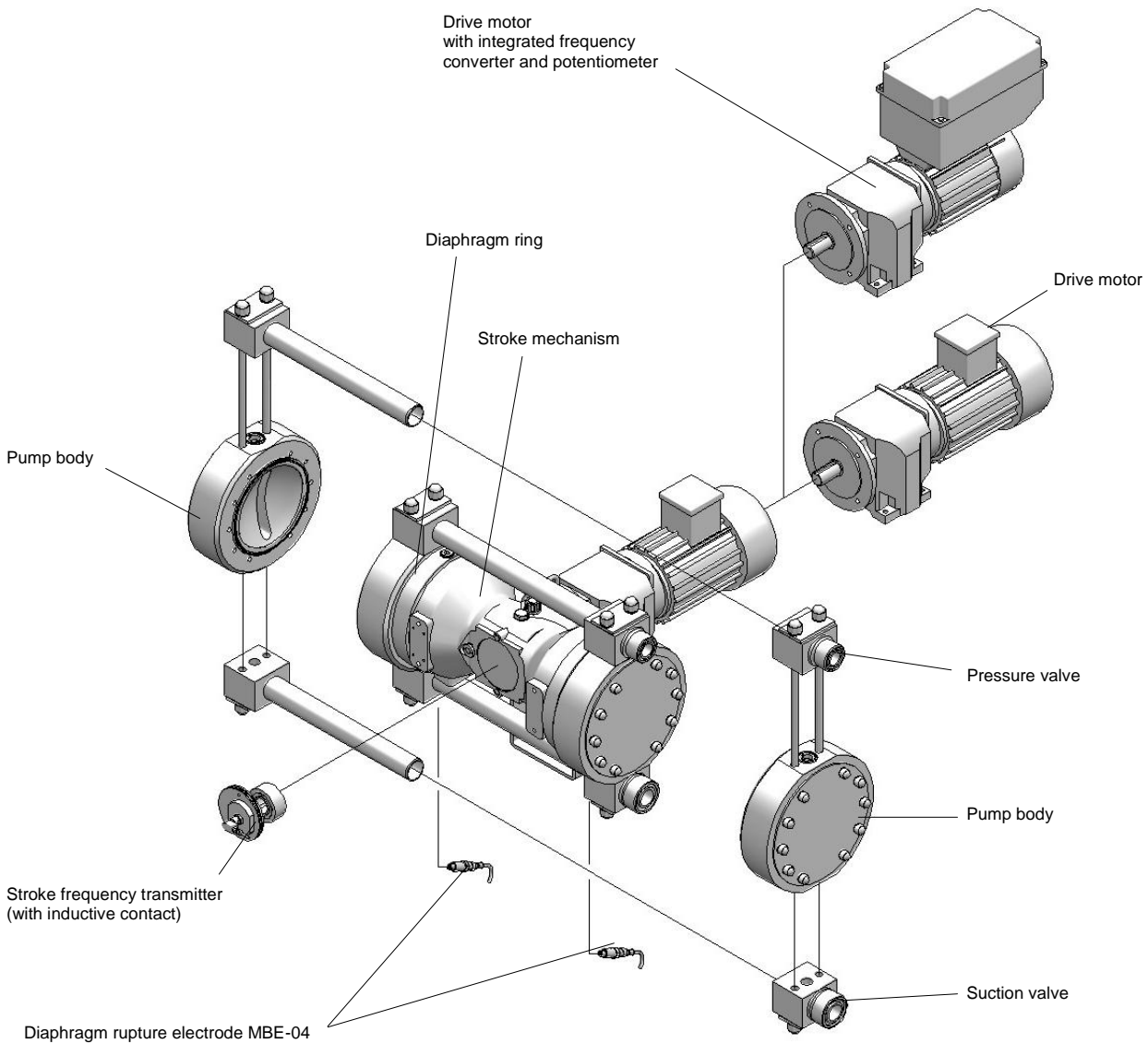

Fig. 04 Overview of the components

Operating Instructions

6 Technical specifications
6.1 Dimensions, plastic design

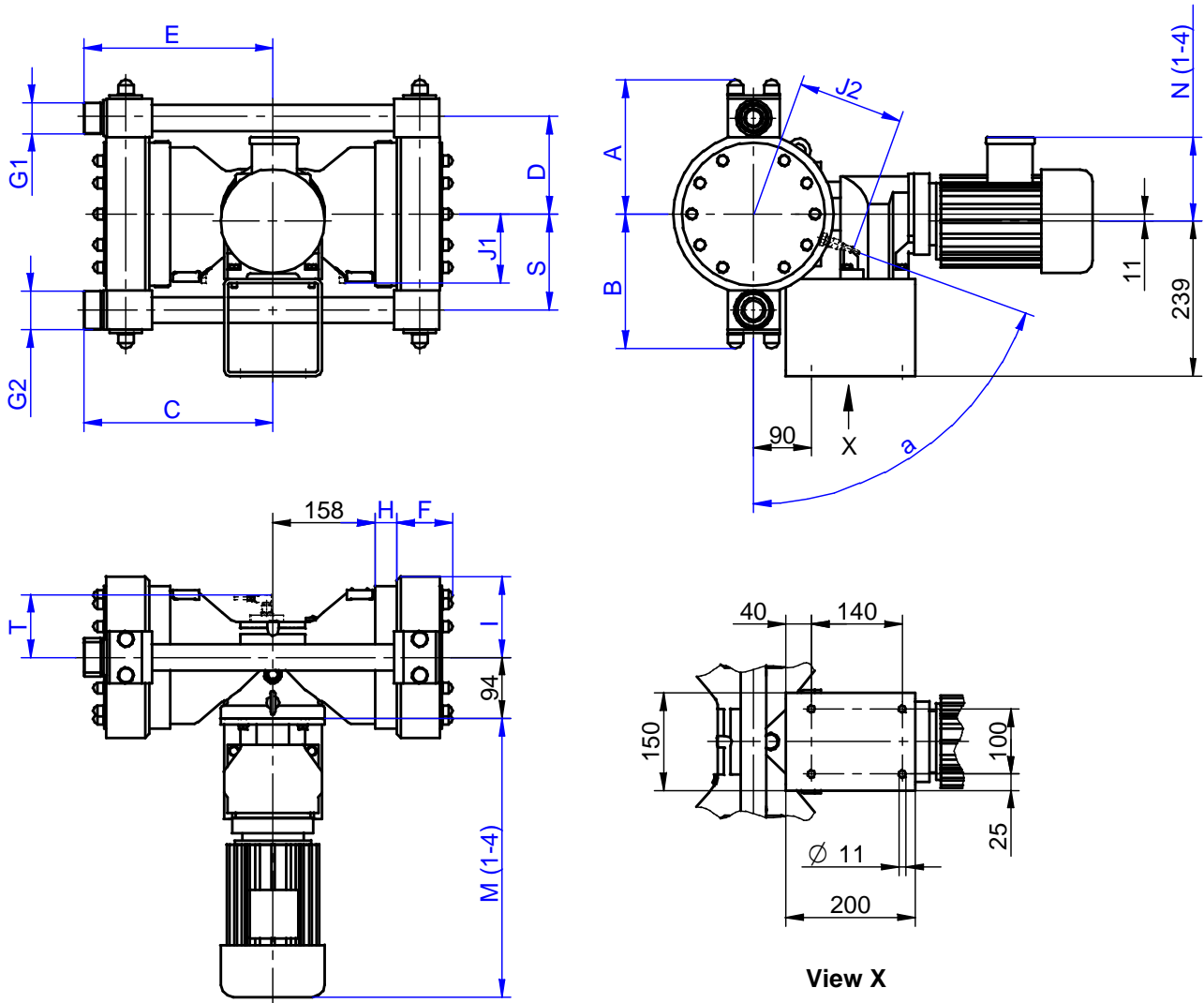

Fig. 05 Dimensions

Operating Instructions

Table. 02
Dimensions

All dimensions in mm!

			Single diaphragm pump			Double diaphragm pump		
			ZX... 411.3 - 2200 e	ZX... 411.3 - 2600 e	ZX... 411.3 - 3100 e	ZX... 411.3 - 2200	ZX... 411.3 - 2600	ZX... 411.3 - 3100
Connection on suction side	S	Single valves PVC, PP, PVDF	222	222	222	222	222	222
	B		252	252	252	252	252	252
	C		281	281	281	314	314	314
	S	Single valves PP-FRP, PVDF-FRP	148	148	148	148	148	148
	B		207	207	207	207	207	207
	C		260	260	260	292	292	292
	G2	Connection thread suction valve	G2	G2	G2	G2	G2	G2
Connection on pressure side	D	Single valves PVC, PP, PVDF	232	232	232	232	232	232
	A		256	256	256	256	256	256
	E		270	270	270	314	314	314
	D	Single valves PP-FRP, PVDF-FRP	148	148	148	148	148	148
	A		207	207	207	207	207	207
	E		260	260	260	293	293	293
	G1	Connection thread pressure valve	G1 ½	G1 ½	G1 ½	G1 ½	G1 ½	G1 ½
Diaphragm ring	H	Diaphragm ring Double diaphragm de- sign	---	---	---	33	33	33
PB	F	Pump body (PB)	86	86	86	86	86	86
	I	PB for valves of PVC, PP, PVDF	110	110	110	110	110	110
		PB for valves of PP-FRP, PVDF-FRP	124	124	124	124	124	124
Drive motor	M1	Standard motor	385	385	385	385	385	385
	N1		121	121	121	121	121	121
	M2	Drive motor with integrated fre- quency converter and potentiometer	430	430	430	430	430	430
	N2		220	220	220	220	220	220
	M3	Drive motor for frequency converte	429	429	429	429	429	429
	N3		130	130	130	130	130	130
	M4	Drive motor (acc. to. ATEX95)	410	410	410	410	410	410
N4	120		120	120	120	120	120	
Option	J1	Diaphragm rupture signalling MBE 02	110	110	110	---	---	---
	J2	Diaphragm rupture signalling MBE 04	---	---	---	163	163	163
	a		---	---	---	70°	70°	70°
	T	Stroke frequency transmitter	97	97	97	97	97	97
Stroke mechnism	a.o. Dimensions for fasten- ing of the pump		see Fig. 05					

Operating Instructions

6.2 Dimensions, special steel design

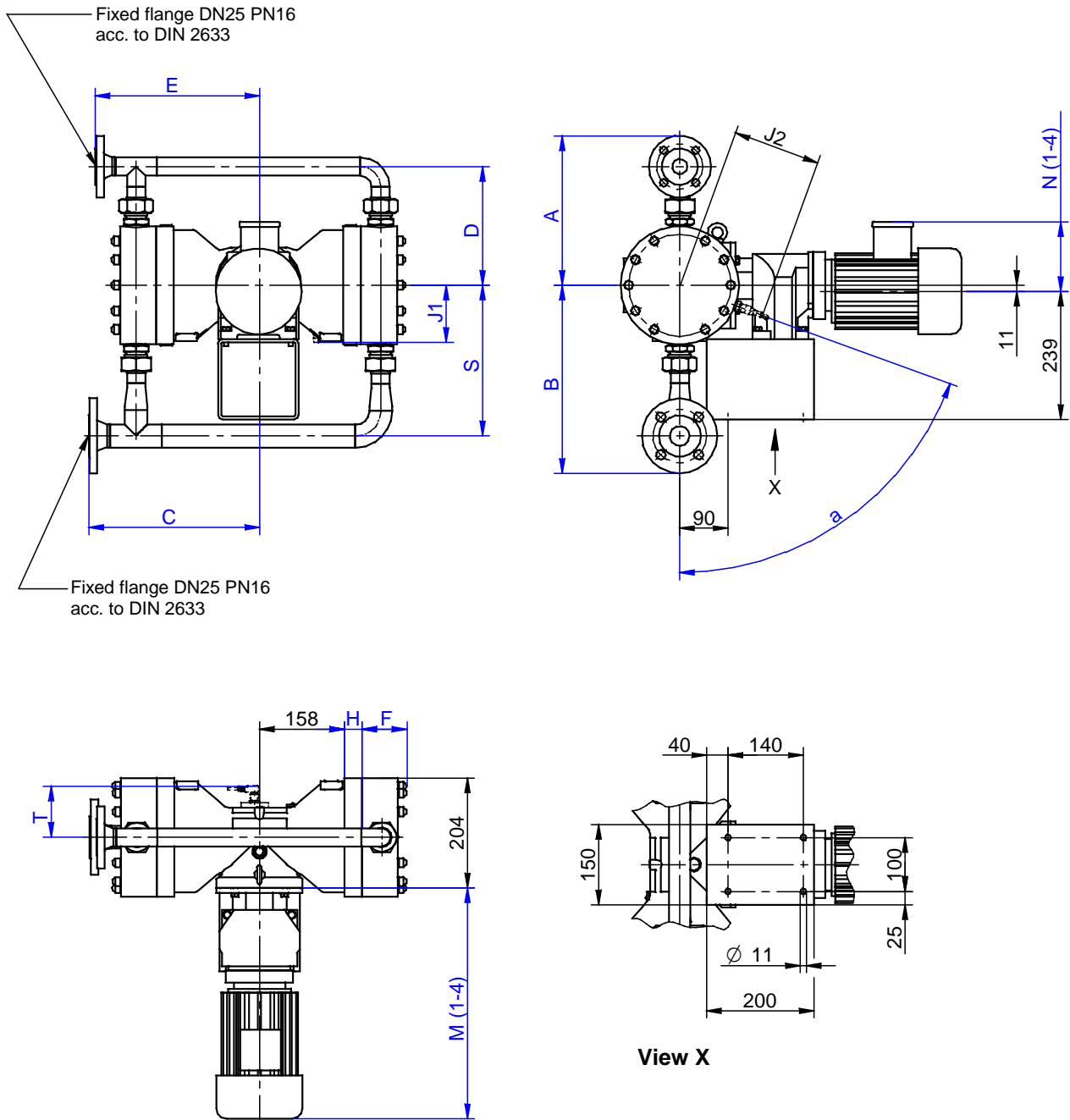

Fig. 06 Dimensions

Operating Instructions

Table. 03
Dimensions

All dimensions in mm!

			Single diaphragm pump			Double diaphragm pump		
			ZX... 411.3 - 2200 e	ZX... 411.3 - 2600 e	ZX... 411.3 - 3100 e	ZX... 411.3 - 2200	ZX... 411.3 - 2600	ZX... 411.3 - 3100
Connection on suction side	S	Single valves 1.4571/1.4581	281	281	281	281	281	281
	B		351	351	351	351	351	351
	C		283	283	283	283	283	283
Connection on pressure side	D	Single valves 1.4571/1.4581	221	221	221	221	221	221
	A		279	279	279	279	279	279
	E		271	271	271	271	271	271
Diaphragm ring	H	Diaphragm ring Double diaphragm design	---	---	---	33	33	33
PB	F	Pump body (PB) 1.4571	83	83	83	83	83	83
Drive motor	M1	Standard motor	385	385	385	385	385	385
	N1		121	121	121	121	121	121
	M2	Drive motor with integrated frequency converter and potentiometer	430	430	430	430	430	430
	N2		220	220	220	220	220	220
	M3	Drive motor for frequency converter	429	429	429	429	429	429
	N3		130	130	130	130	130	130
	M4	Drive motor (acc. to. ATEX95)	410	410	410	410	410	410
	N4		120	120	120	120	120	120
Option	J1	Diaphragm rupture signalling MBE 02	110	110	110	---	---	---
	J2	Diaphragm rupture signalling MBE 04	---	---	---	163	163	163
	a		---	---	---	70°	70°	70°
	T	Stroke frequency transmitter	97	97	97	97	97	97
Stroke mechanism	a.o. Dimensions for fastening of the pump		see Fig. 06					

Operating Instructions

6.3 Performance data

Type	Pump data											
	Nominal delivery rate ²⁾ adjustable by stroke length adjustment		Maximum permissible pressure in the pump out- let	Minimum / maximum permissible pressure in the pump inlet	Maximum suction height ⁽¹⁾	Inlet nominal width	Outlet nominal width	Nominal stroke frequency		Maximum stroke length	Motor size (standard design)	Weight (standard design)
	Q _N l/h		p ₂ max.	p ₁ min. / max.	WC	DN	DN	min ⁻¹		h100	BG	app. kg
	50 Hz	60 Hz	bar	bar	m	mm	mm	50 Hz	60 Hz	mm		
ZXM 411.3 – 2200 e	2200	2640	4	-0,8/0	8	32	25	92	110	20	80	70
ZXM 411.3 – 2200	2200	2640	4	-0,3/0	3	32	25	92	110	20	80	80
ZXM 411.3 – 2600 e	2600	3120	4	-0,8/0	8	32	25	103	123	20	80	70
ZXM 411.3 – 2600	2600	3120	4	-0,3/0	3	32	25	103	123	20	80	80
ZXM 411.3 – 3100 e	3100	---	4	-0,8/0	8	32	25	128	---	20	80	70
ZXM 411.3 – 3100	3100	---	4	-0,3/0	3	32	25	128	---	20	80	80
ZXRI 411.3 – 2200 e	230 – 2200		4	-0,8/0	8	32	25	84	---	20	80	80
ZXRI 411.3 – 2200	230 – 2200		4	-0,3/0	3	32	25	84	---	20	80	90
ZXRI 411.3 – 2600 e	230 – 2600		4	-0,8/0	8	32	25	110	110	20	80	80
ZXRI 411.3 – 2600	230 – 2600		4	-0,3/0	3	32	25	110	110	20	80	90
ZXRI 411.3 – 3100 e	230 - 3100		4	-0,8/0	8	32	25	123	123	20	80	80
ZXRI 411.3 – 3100	230 - 3100		4	-0,3/0	3	32	25	123	123	20	80	90

Table. 04 Performance data

1) Achievable height with media similar to water and filled suction line

2) Linear dosing range at a stroke frequency between 20 und 100%

6.4 Motor data

Motor type	Motor data												
	Output	Motor speed		Mains fre- quency	Voltage range	Nominal cur- rent	Protection category	Thermal class	ATEX-design				
		[kW]	[min ⁻¹]							[Volt]	[A]	[IP]	
			50 Hz							60 Hz	50 Hz / 60 Hz	50 Hz / 60 Hz	
Standard motor	0,75	1400	1675	50/60	Observe the type plate! The data can be read off the type plate on the drive motor of the respective diaphragm pump !	55	F	---					
Motor for frequency converter operation	1,1	1420	1710	50/60		55	F						
EExellT4- motor	0,55	1400	---	50		55	F	II2GEEellT4					
EExdelICT4-motor (pressure-tight enclosed)	0,75	1380	---	50		55	F	II2GEEdelICT4					

Table. 05 Motor data

Operating Instructions

7 Functional description

7.1 General

sera - diaphragm pumps are run-dry safe oscillating displacement pumps that are characterised by high tightness of the dosing head. The liquid is conveyed by a deformable drive diaphragm.

Diaphragm pumps consist of the following (main) components:

- Drive motor
- Stroke mechanism
- Pump bodies
- Suction and pressure valves

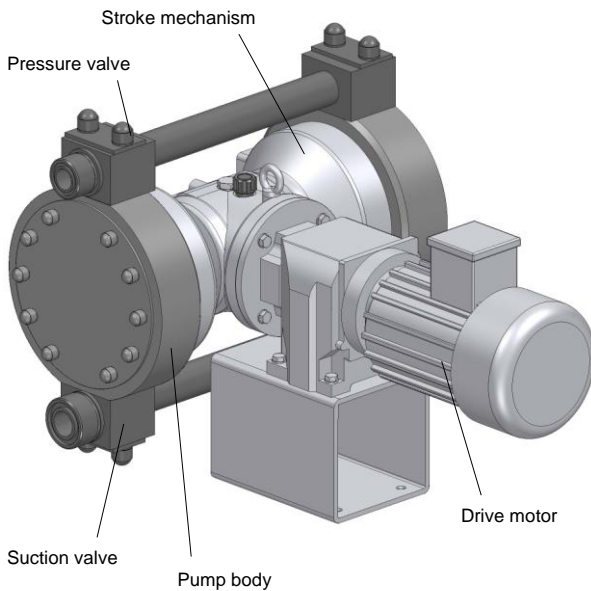

Fig. 07 Components

7.2 Components of the diaphragm pump ZYM 409.1

7.2.1 Stroke mechanism

Function

With diaphragm pumps of this series the rotation of the drive motor is transferred to two opposite, rigidly coupled displacers via an eccentric which is positively driven in the connecting rod. The displacers - directly driven via the connecting rod – approach the suction and pressure stroke with a constant stroke length (offset by 180°). While one of the dosing heads sucks the medium in the other dosing head feeds it and vice versa.

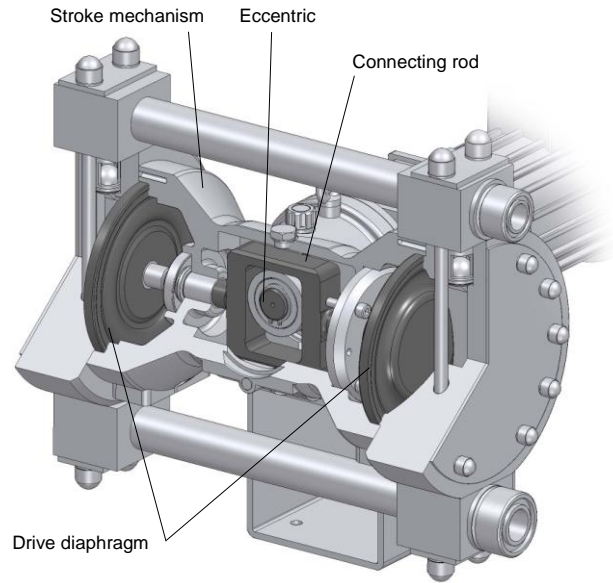

Fig. 08 Stroke mechanism

General

There are two different pump types:

- a) Single diaphragm pump
- b) Double diaphragm pump

Function

- a) Single diaphragm pump

The drive diaphragm connected to the drive via the connecting rod transmits the stroke movement directly to the pumped medium.

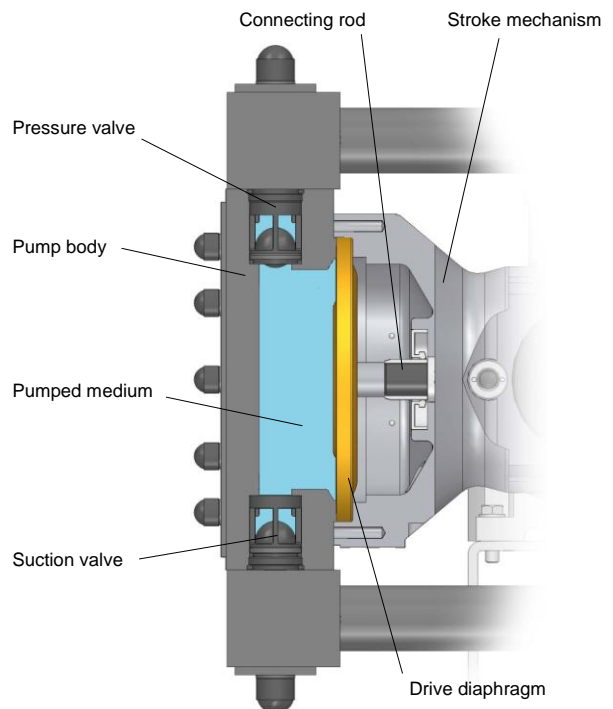

Fig. 09 Functional principle of the single diaphragm pump

Operating Instructions

b) Double diaphragm pump

The stroke movement of the drive diaphragm is transmitted hydromechanically to the intermediate diaphragm which is in contact with the medium.
The intermediate diaphragm protects the drive diaphragm from chemical affects of the pumped medium.

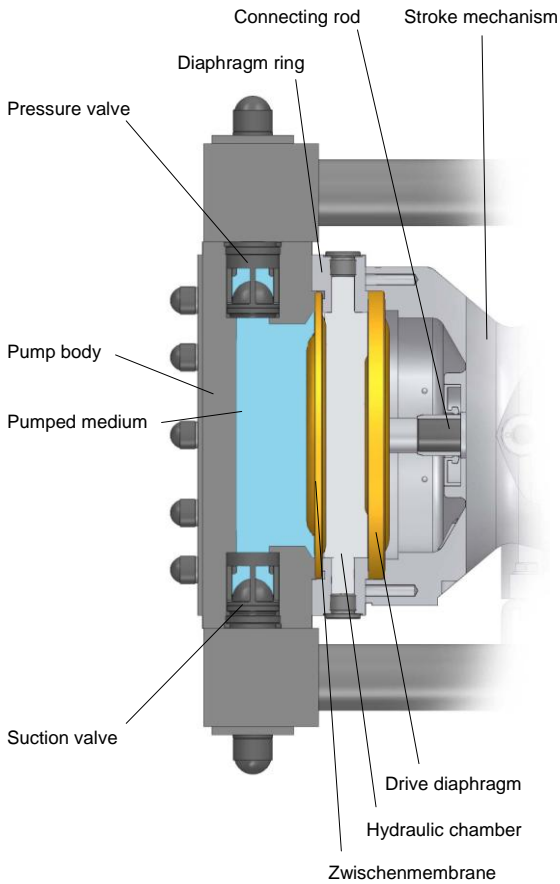

Fig. 10 Functional principle of the double diaphragm pump

A proper function can only be guaranteed when there are no gas- or air bubbles in the hydraulic chamber and the correct volume of buffer fluid has been filled in.

7.2.2 Pump body

Depending on the applied backpressure, movements of the plastic pump body in elastic materials are possible. This does not affect the pumps's service life or operational reliability.

7.2.3 Suction/pressure valve

The pump valves are always ball valves which can only function properly when they are installed in a vertical position. The condition of the valves is decisive for the operational behaviour of the pump. The valves should only be exchanged completely. Pay attention to the flow direction when installing the valves (see Fig. 11).

The suction and pressure valves of the two pump heads are each brought together to a horizontal suction and pressure connection (see fig. 11). The pump has a bigger connection at the suction side in order to improve the filling degree.

CAUTION !



Pressure valve above, suction valve below!

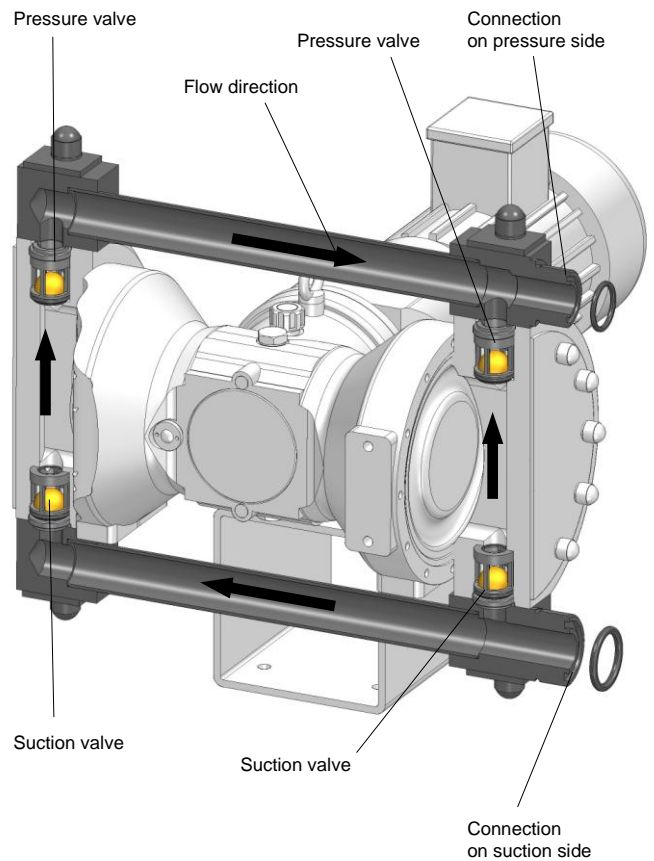

Fig. 11

Operating Instructions

7.2.4 Stroke frequency transmitter (option)

sera – dosing pumps are oscillating displacement pumps with an exactly defined stroke volume per each pump stroke.

If these dosing pumps should be used for automatic filling processes or charge dosing, then the single pump strokes must be determined and converted into electrical signals.

For this purpose, a stroke frequency transmitter (inductive contactor) is added to the pump and reports each single pump stroke to the evaluation unit (e.g. preselection counter, SPS-control unit, etc.)

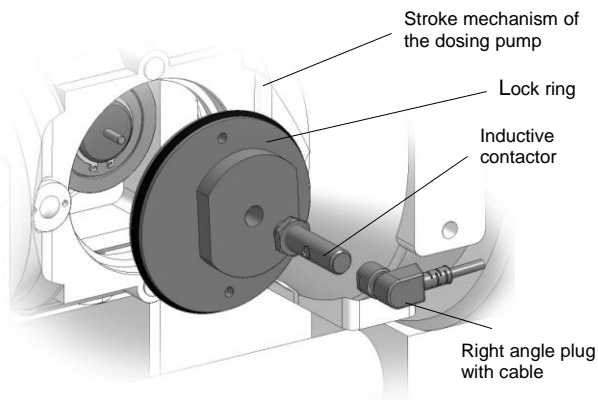
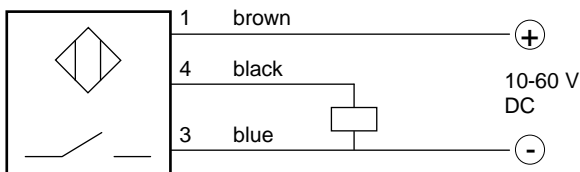

Fig. 12 Stroke frequency transmitter

Technical specifications

- Nominal voltage: 10 - 60 V DC
- Steady current: < 200 mA
- Short-circuit proof
- Connection: Plug connector with 2 m cable
- LED (green): Indicates supply voltage
- LED (yellow): Indicates switching status

Circuit diagram



CAUTION !

When switching inductive loads (protectors, relays, etc.), surge protectors (varistors) must be fitted owing to the high self-induction voltage.

CAUTION !

For usage in explosion-hazardous areas a NAMUR-type stroke frequency transmitter is to be provided (II2G EExia IICT6, according to ATEX95).

7.2.5 Diaphragm rupture monitoring device (option)

sera - diaphragm pumps of the 411.3 series can be equipped with a conductive diaphragm rupture monitoring device as option.

CAUTION !

The pumped medium must have a minimum conductivity of at least 5 µS/cm!

An electrode together with an appropriate evaluation unit (option, e.g. sera – diaphragm rupture relay, type ER-104 (or ER-142 for Ex-areas respectively) is used for monitoring.

The diaphragm rupture electrode is mounted directly to the pump, the evaluation unit inside the switch cabinet.

One must distinguish between the single and the double diaphragm pump.

The diaphragm rupture electrode type MBE-02 is used for single diaphragm pumps, type MBE-04 for double diaphragm pumps.

Single diaphragm pump

The diaphragm rupture electrode type MBE-02 is put in the base ring of the dosing pump from below (please see Fig. 03)

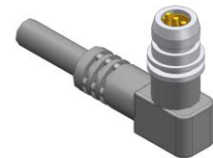

Fig. 13 MBE-02

Double diaphragm pump

The diaphragm rupture electrode type MBE-04 is mounted in the side of the diaphragm ring of the dosing pump (please see Fig. 04)



Fig. 14 MBE-04

CAUTION !

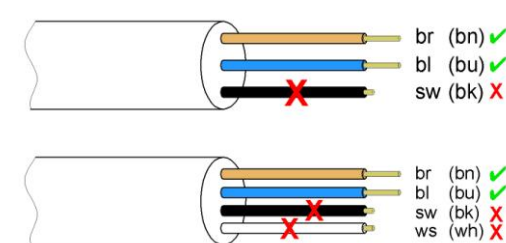

CAUTION !

sera - diaphragm pumps can be retrofitted with a diaphragm rupture electrode.

Maintenance of the diaphragm rupture electrodes is limited to cleaning (e.g. during an exchange, please see Chapter 10.4)

Operating Instructions

7.3 Drive motor

sera - diaphragm pumps are driven by a three-phase motor or an AC motor.

7.3.1 Motor connection (standard)

In case of a three-phase motor

The motor connection depends on the voltage specification on the type plate and the applied supply voltage.

ZXM / ZXRF

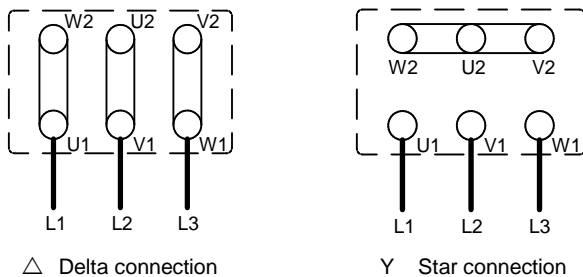

ZXRI

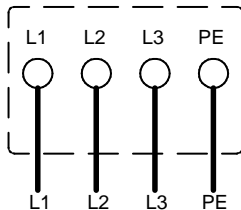

Fig. 15 Circuit diagram(s) of three-phase motor

Example:

Specification on type plate:	230/400 V
Existing three-phase mains:	400 V
Correct motor connection:	Y Star connection

7.3.2 Direction of rotation

The rotating direction of the drive motor is arbitrary.

7.3.3 Terminal box

Before closing the terminal box, please check that:

- all terminal connections are tightly fitted
- the interior is clean and free from foreign bodies
- unused cable entries are closed and screw plugs are tightened
- the sealing is correctly inserted in the cover of the terminal box; check proper condition of all sealing surfaces so that the requirements of the protection category are fulfilled.

7.3.4 Start-up

Preconditions:

Make sure that voltage and frequency correspond with the specifications on the type plate of the motor. Permissible voltage tolerance (DIN VDE 0530)
for rated voltage + 10 %
for rated voltage range +/- 5 %

The connecting cable must be dimensioned according to the motor characteristics.

Secure connecting cable with a strain relief.

The nominal motor power refers to an ambient temperature of 40°C and an installation site below 1000m above sea level. Motor output will be reduced if these values are exceeded (see VDE 0530).

Adapted for "moderate" group of climates according to IEC 721-2-1.

CAUTION !



The drive motor will heat by operation of the pump. Do not touch the motor during operation!

7.3.5 Motor protection

Provide for adequate motor protective equipment in order to protect the motor from overload (e.g. protective motor switch with thermal overcurrent release). Connect the ground wire to the marked earth screw in accordance with VDE 0100.

CAUTION !



Fuses do not protect the motor.

7.3.6 Maintenance of the drive motor

The electric motor should always be kept clean so that neither dust, dirt, oil nor other contaminants may affect the correct operation.

In addition, we recommend to ensure that:

- the motor does not produce strong vibrations
- suction and blowing openings for the supply of cooling air are not closed or restricted (may lead to unnecessary high temperatures in the windings).

The ball bearings inserted in the motor are lubricated for life.

7.3.7 Restart

Restart the system as described in Chapter 7.3.4 after maintenance work of after longer periods of standstill.

Operating Instructions

8 Assembly / Installation

CAUTION !



The notes in Chapter 9 are to be observed if the pump is operated in explosion-hazardous areas.

8.1 Installation instructions

- The standard model of the pump is only approved for installation in dry rooms in a non-aggressive atmosphere, at temperatures between +2°C and +40°C and at permitted humidity until approx. 90%. (For operation in explosion-hazardous areas, see Chapter 9).
- For dimensions of the pump connections and fixing holes, see Fig. 05 - 06, Tab. 02 - 03
- Install the pump in such a way that there is no vibration and no tension and that it is aligned precisely.
- Erect pump in a user-friendly height. Mount pump in a way that the valves are vertical and the connections at the suction and pressure side horizontal.
- Ensure that there is sufficient space around the pump body and the suction and pressure valve so that these parts may be easily dismantled, if required.
- Design the nominal diameters of the downstream pipes and of the connections built into the system to be the same size or larger than the nominal inlet and outlet diameters of the pump.
- To check the pressure ratios in the pipe system, we recommend to provide for connections for pressure gauges (e.g. manometers) near the suction and pressure sockets.
- Drain cocks are to be provided
- Prior to connecting the pipes, remove the plastic caps on the suction and pressure sockets of the pump (see Fig. 15).
- Check that the fixing screws for the pump body are tightly fitted

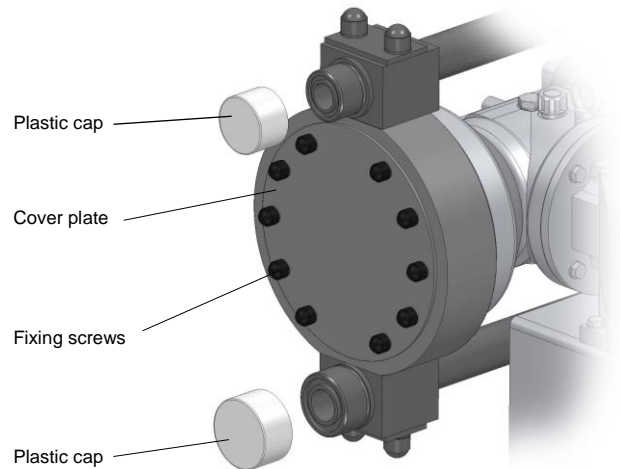

Fig. 16 Diaphragm pump with plastic caps

- Connect pipes to the pump in such a way that there are no forces acting on the pump, such as e.g. misalignment, weight or stress of the pipe.
- Keep the suction lines as short as possible.
- Use pressure- and medium-resistant hoses / pipes.
- All pipes and containers connected to the pump must comply with the regulations and must be cleaned, tension-free and intact.

CAUTION !



If toxic, crystallizing or corrosive liquids are conveyed the pipe system is to be equipped with facilities for emptying, cleaning and rinsing with an appropriate medium, if necessary.

CAUTION !



If the pump is connected to a 60Hz mains the pipe geometry must be designed according to the elevated stroke frequency.

CAUTION !



Mount the diaphragm pump in such a way that leaking medium cannot cause any damage.

Tightening torques of the fixing screws

Pump type	Pump body without front plate	Pump body with front plate
ZX... 411.3 – 2200 (e)	15 Nm	15 Nm
ZX... 411.3 – 2600 (e)		
ZX... 411.3 – 3100 (e)		

Table. 06 Tightening torques

Operating Instructions

In order to avoid cavitation, overloading and excessive delivery, the following points should be noted:

- avoid high suction heights
- keep pipes as short as possible
- choose sufficiently large nominal diameters
- avoid unnecessary choke points
- install a pulsation damper
- install a pressure relief
- install a pressure keeping valve, if necessary
- in the case of degassing media, provide for a supply

CAUTION !



The operator must provide for appropriate protective measures (collecting basin, diaphragm rupture electrode) in the supply pipe so that the container does not drain off in case of a diaphragm rupture.

8.1.1 Provide overpressure protection

if the permissible pressure in the pump head may be exceeded, e.g. when a shut-off valve is closed or if the line is blocked:

- install overflow valve (Fig. 17)

When using an overflow valve, please note for the return line:

- lead the overflow line with descending gradient in the storage tank which is under atmospheric pressure or in an open drain gutter
- or connect the overflow line directly to the pump suction line, but only if there is no check valve inside the suction line (e.g. foot valve of a suction lance) (please see. Fig. 18)

CAUTION !



Shut-off valves must not be closed when the pump is running!

CAUTION !



Provide an overpressure protection (e.g. overflow valve) if the permissible operating pressure may be exceeded.

CAUTION !



If the permissible operating pressure is exceeded and the pump is not equipped with an overpressure protection the pump can get damaged.

CAUTION !



The pumped medium may spout out if the pump is damaged.

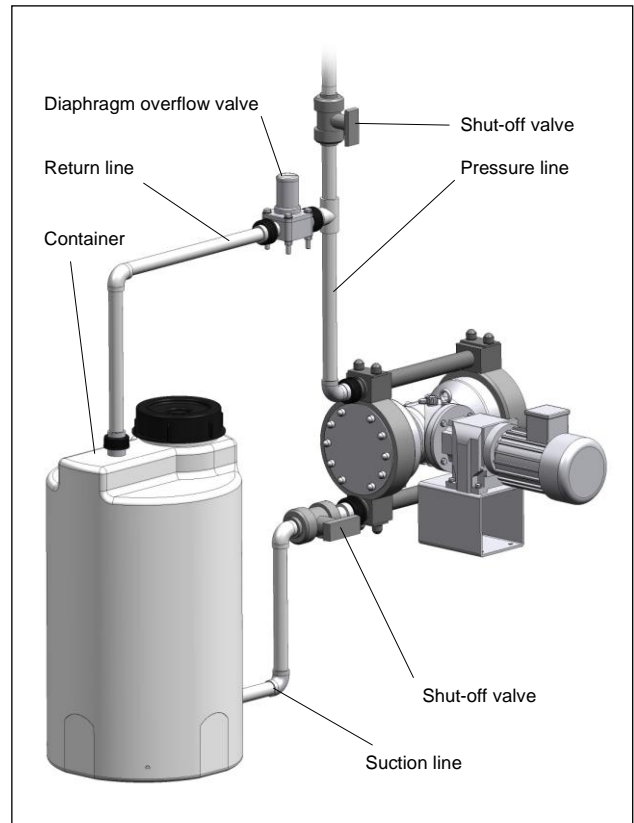

Fig. 17 System with overflow valve

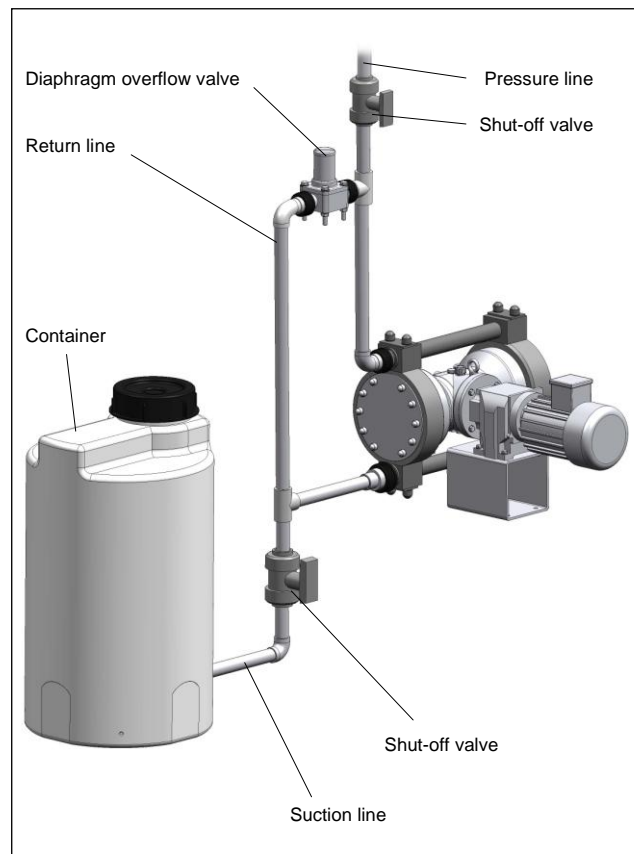

Fig. 18 System with overflow valve

Operating Instructions

8.1.2 Prevent a backflow of the pumped medium

if the dosing line is linked with a main line:

- install an injection fitting (dosing valve).

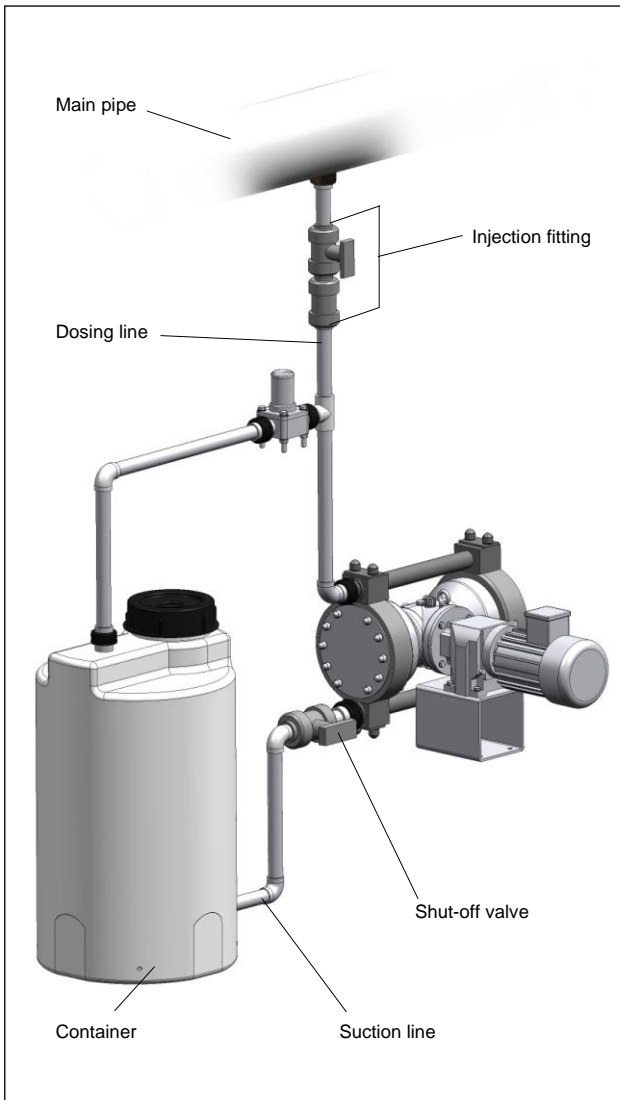

Fig. 19 Installing an injection fitting

CAUTION !



The contents in the dosing line is mixed unintentionally if a backflow from the main pipe is not prevented.

CAUTION !



Note / avoid chemical reactions during a backflow.

8.1.3 Eliminate undesired siphoning

when dosing into a main line with negative pressure:

- install a pressure keeping valve in the dosing line.

CAUTION !



When installing the pump it is to be ensured that an excess supply (due to a positive pressure difference (≥ 1 bar) between pressure and suction side) is avoided.

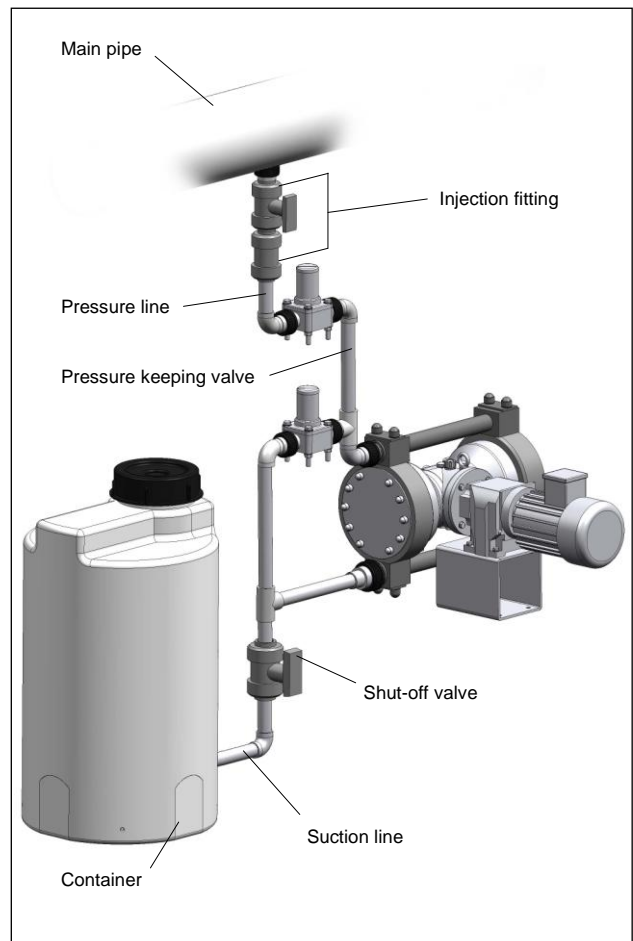

Fig. 20 Installing a pressure keeping valve

Operating Instructions

8.1.4 Install the empty-tank alarm

so that the tank is refilled before air is drawn in.

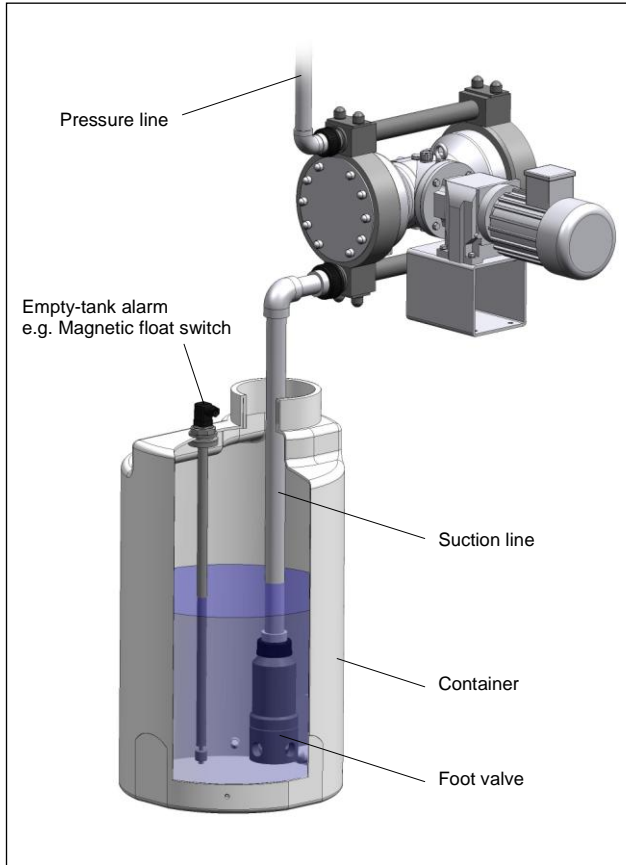

Fig. 21 Installing an empty-tank alarm

CAUTION !



The delivery flow may be interrupted if air enters the suction line!

8.1.5 How to avoid an emptying of the suction line

- Install a foot valve at the end of the suction line.

Based on calculations, the dimension 'H' may not exceed the number that is equal to the specified maximum suction height of the pump divided by the density of the pumped medium and under consideration of mass acceleration and viscosity of the medium.

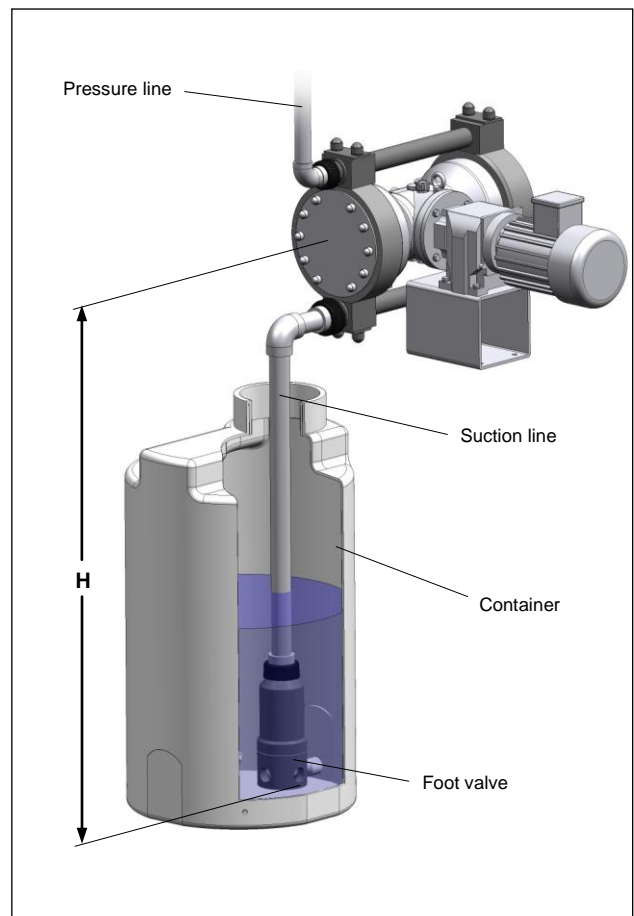

Fig. 22 Avoiding an emptying of the suction line

Operating Instructions

8.1.6 Line strainer

- Connect the suction line slightly above the bottom of the tank and install a line strainer (0.1 – 0.5mm aperture size – depending on nominal width of the valve).

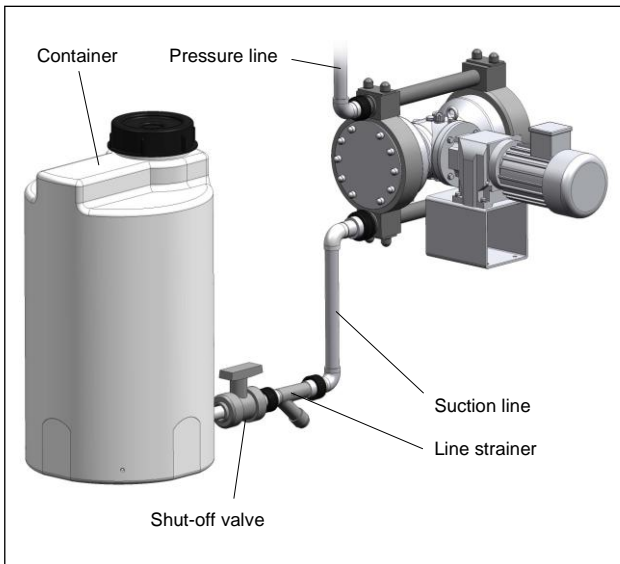

Fig. 23 Installing a line strainer

CAUTION !



If contaminations are not removed this may result in malfunctions of the pump and the system.

8.1.7 Suction via a siphon pipe

for use with high tanks without connection on the bottom of the tank:

- Install a siphon tank.
- Pay attention to acceleration pressures which may be generated in a long suction line.

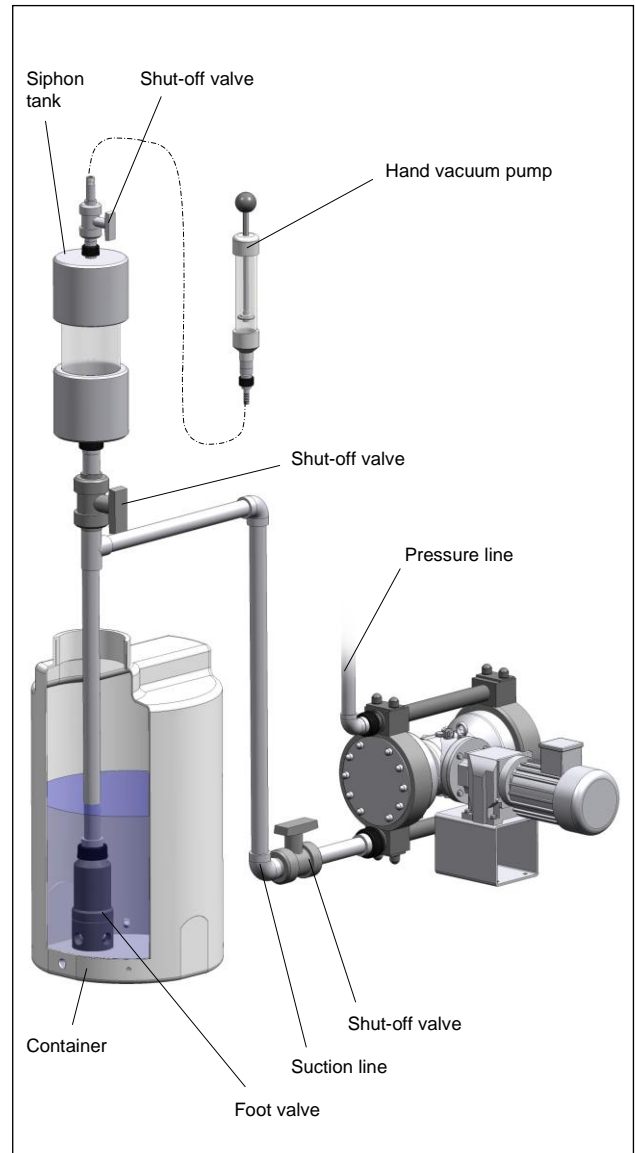

Fig. 24 Installing a siphon tank (**sera** - fitting)

Operating Instructions

8.1.8 In case of slightly degassing dosing media

- Install the pump in such a way that it can be operated with a supply line.

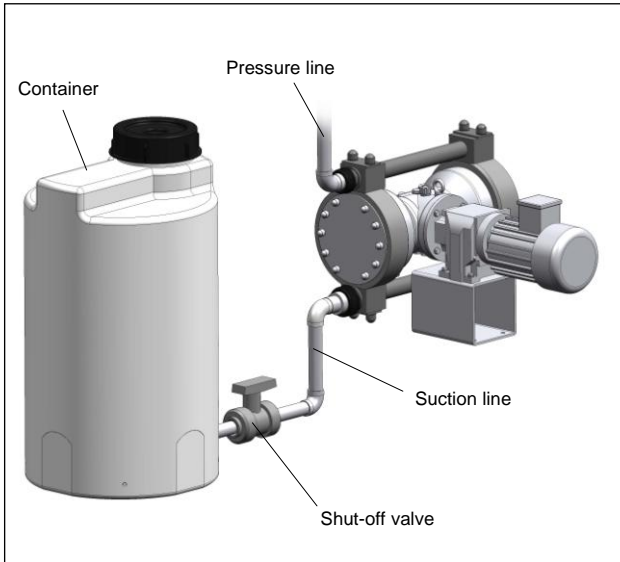

Fig. 25 Installation with supply line

8.1.9 Dosing of suspensions

requires that the pump head is rinsed to prevent precipitations. The following methods are recommended:

- intermittent rinsing
- or
- rinsing when the pump was switched off

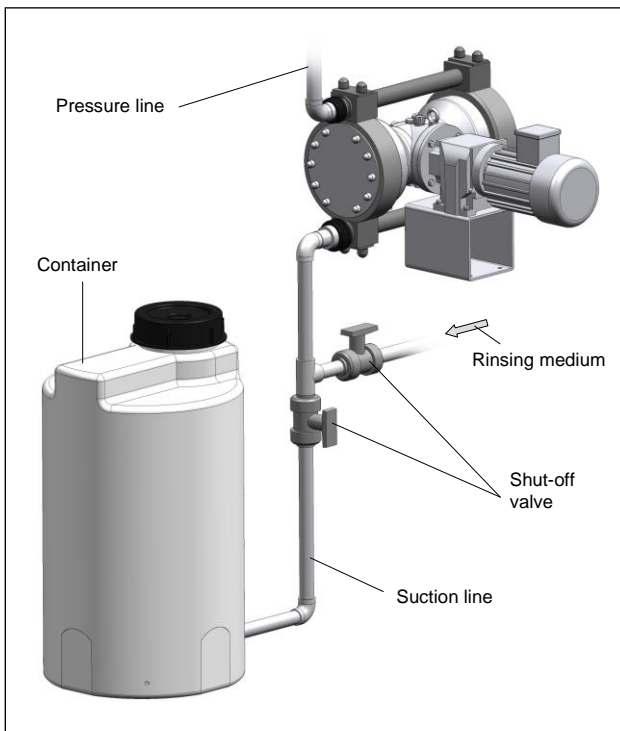

Fig. 26

8.1.10 Damping of the pulsation

by installing pulsation dampers if:

for procedural reasons, a pulsation-poor delivery rate is desired.

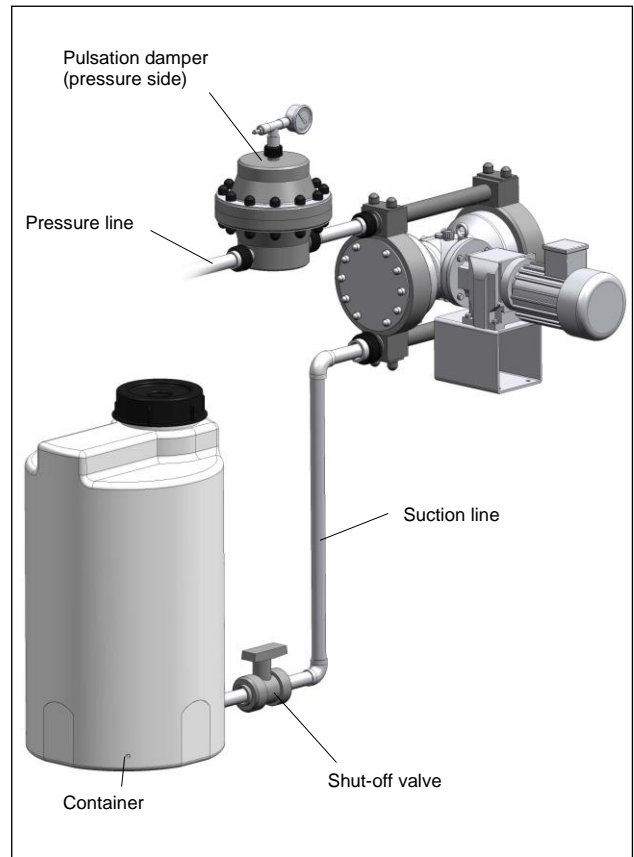

Fig. 27 Installing a pulsation damper (I)

Operating Instructions

Acceleration forces which arise due to the pipe geometry must be reduced.

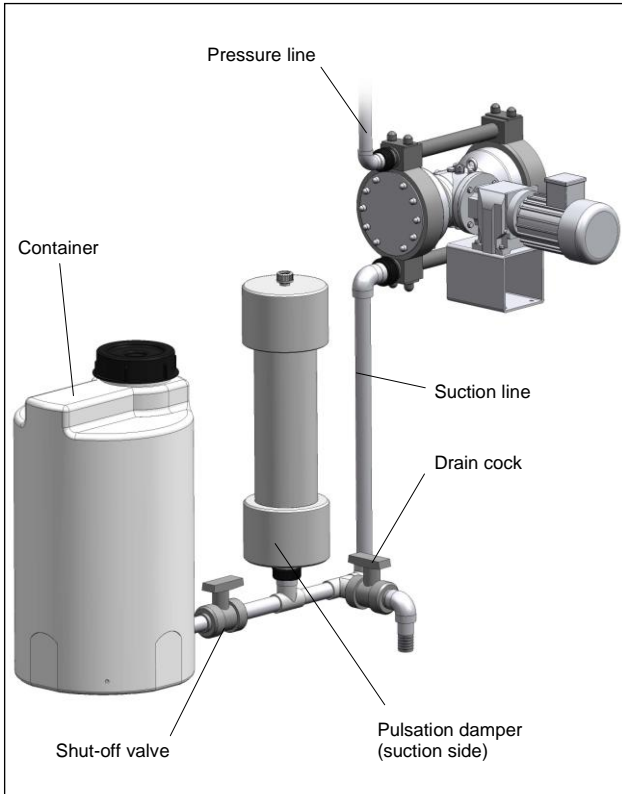

Fig. 28 Installing a pulsation damper (II)

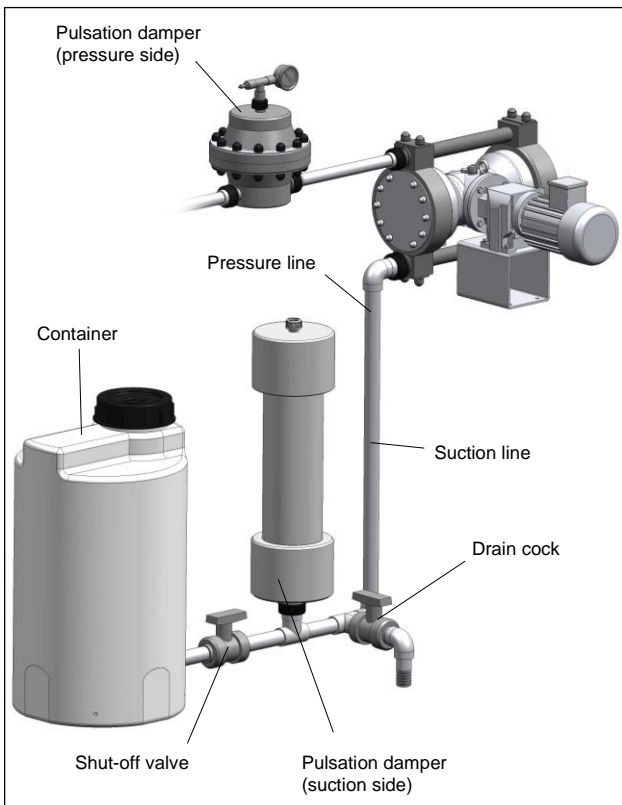

Fig. 29 Installing a pulsation damper (III)

CAUTION !



Undamped acceleration forces may lead to the following faults / damage:

- delivery rate fluctuations
- dosing errors
- pressure surges
- valve wobbles
- increased wear on the suction- and pressure side of the pump;

mechanical damage of the pump
leakage and valve wobbles if the permissible maximum pressure on the pump pressure side is exceeded.

Installation of suction and/or pressure pulsation damper near the pump head.

- If both pulsation damper and pressure keeping valve should be integrated install the pressure keeping valve between pump and pulsation damper.

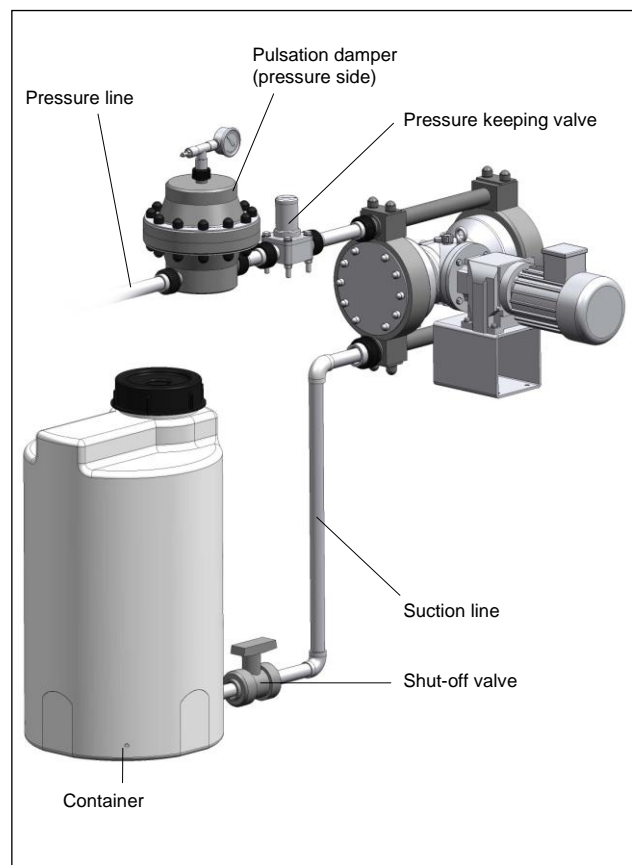

Fig. 30 Installing a pulsation damper and a pressure keeping valve

Operating Instructions

9 Peration in explosion-hazardous areas

9.1 General

CAUTION !



The prerequisite for the use in explosion-hazardous areas is an appropriate design of the pump.

The product supplied by **sera** meets the requirements of directive 94/9/EC. This guarantees safe operation in explosion-hazardous areas.

CAUTION !



It is the operator's task to define the field of application and to check whether the pump is suited for this application. He/she must clearly define the zone, the device category, the explosion group and the temperature class.

9.2 Identification

A label regarding the the area/category/explosion group/temperature class in compliance with directive 94/9/EC is directly attached to the pump.

- Ex II2G c IIBT4 or
- EX II2G c IICT4

(Special specifications in the order confirmation are to be observed)

9.3 Installation

9.3.1 General

The intended operating conditions in explosion-hazardous areas in compliance with the directive 94/9/EC can be seen from the order confirmation and the product description. The limit values mentioned therein may not be exceeded or fallen below.

Installation regulations given in the operating instructions must be adhered to.

9.3.2 Working in explosion-hazardous areas

CAUTION !



Use only suitable tools for performing assembly and maintenance work on machines or plants in explosion-hazardous areas. Directive 99/92/EC must be observed.

9.4 Potential equalisation

After fixation, make sure that the pump is properly connected to the potential equalisation system on site.

9.5 Start-up

After installation, the pump must immediately be used for the suction of fluids, i.e. the pump must immediately be started after the tank has been installed and filled.

9.6 Operation

9.6.1 General

The intended operating conditions in explosion-hazardous areas in compliance with the directive 94/9/EC can be seen from the order confirmation and the product description. The limit values mentioned therein may not be exceeded or fallen below.

Details about explosion areas, device category, explosion group and temperature class can be seen from the Declaration of Conformity.

9.6.2 Degassing of the pumped medium

Never let the pump run dry. Check the liquid level in the tank during operation of the pump. Make sure that the pump is switched off if the liquid level in the tank falls below the minimum level required (explosive atmosphere may be carried over).

Vapour bubbles from the pumped medium are harmless as they have no explosive potential.

CAUTION !



Formation of an explosion-hazardous gas mixture is to be excluded.

9.6.3 Temperature indications

permissible ambient temperature

$$0^{\circ}\text{C} \leq T_a \leq +40^{\circ}\text{C}$$

9.7 Maintenance

The maintenance notes listed in Chapter 10 are generally applicable.

Exception:

CAUTION !



The oil level in the stroke mechanism of the pump must be checked once a week!

Operating Instructions

10 Maintenance

CAUTION !



Before starting maintenance work make sure the the spare and wearing parts as well as the utilities required are available.
Place / deposit components in such a way that any damage is prevented.

CAUTION !



Check the wearing parts for proper functioning at regular intervals and replace, if necessary.

The following checks should be carried out at regular intervals:

- tight fit of the the pipework
- tight fit of pressure and suction valve
- proper condition of the electrical connections
- tight fit of the screws for fastening the pump body (check this at least every three months)
For the tightening torques of the fixing screws, please see Chapter 8.1 "Installation", Table.06.

Repairs on the stroke mechanism may only be performed by **sera**.

10.1 Wearing parts

Depending on their use and period of use, wearing parts must be replaced at regular intervals in order to ensure a safe function of the diaphragm pump.

We recommend to replace the drive- or intermediate diaphragms after 3000 operating hours or at least once a year.

In case of a premature diaphragm rupture caused by hard operating conditions, switch off the diaphragm pump and replace the diaphragms (see Chapter 10.4).

As an option, the diaphragm pump can be equipped with a diaphragm rupture monitoring device MBE-... (please see Chapter 7.2.8).

The following parts are considered as wearing parts of the diaphragm pump:

- Drive diaphragm
- Intermediate diaphragm (only for double diaphragm pump)
- Suction valve
- Pressure valve

10.2 Spare parts

The following parts are considered as spare parts of the diaphragm pump:

- Pressure joint
- Suction joint
- Pump body
- Diaphragm ring (only for double diaphragm pump)

Operating Instructions

10.3 Spare and wearing parts

10.3.1 (PP-FRP/PP, PVDF-FRP/PVDF)

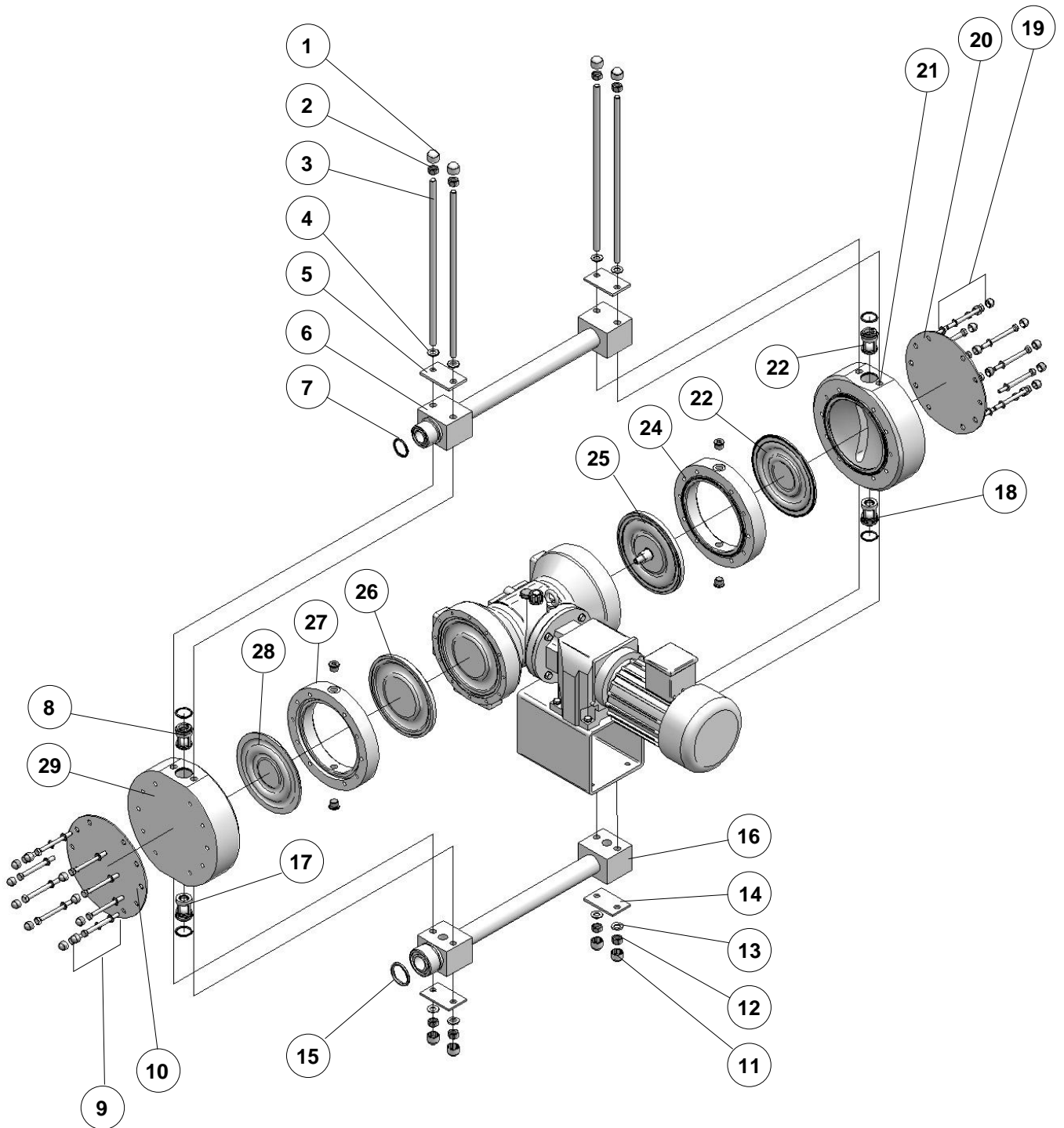

Fig. 31.1 Spare- and wearing parts (PP-GFK/PP, PVDF-GFK/PVDF)

Operating Instructions

Overview of the spare and wearing part kits (PP-FRP/PP, PVDF-FRP/PVDF)

Suction valve (kit)	
Item	Designation
18	Suction valve (incl. o-rings)
17	Suction valve (incl. o-rings)

Pressure valve (kit)	
Item	Designation
22	Pressure valve (incl. o-rings)
8	Pressure valve (incl. o-rings)

Suction joint (kit)	
Item	Designation
11	Protecting caps
12	Nuts
13	Disks
14	Front plates
15	O-Ring
16	Suction joint

Pressure joint (kit)	
Item	Designation
1	Protecting caps
2	Nuts
3	Stud bolts
4	Disks
5	Front plates
6	Pressure joint
7	O-Ring

Diaphragm kit (single diaphragm pump)	
Item	Designation
25	Drive diaphragm
26	Drive diaphragm

Diaphragm kit (double diaphragm pump)	
Item	Designation
22	Intermediate diaphragm
25	Drive diaphragm
	Buffer fluid
28	Intermediate diaphragm
26	Drive diaphragm
	Buffer fluid

Diaphragm ring kit (only for double diaphragm pump)	
Item	Designation
24	Diaphragm ring, complete
27	Diaphragm ring, complete

Pump body kit (plastic)	
Item	Designation
19	Screws, complete
20	Front plate
21	Pump body
9	Screws, complete
10	Front plate
29	Pump body

Operating Instructions

10.3.2 (PVC-U)

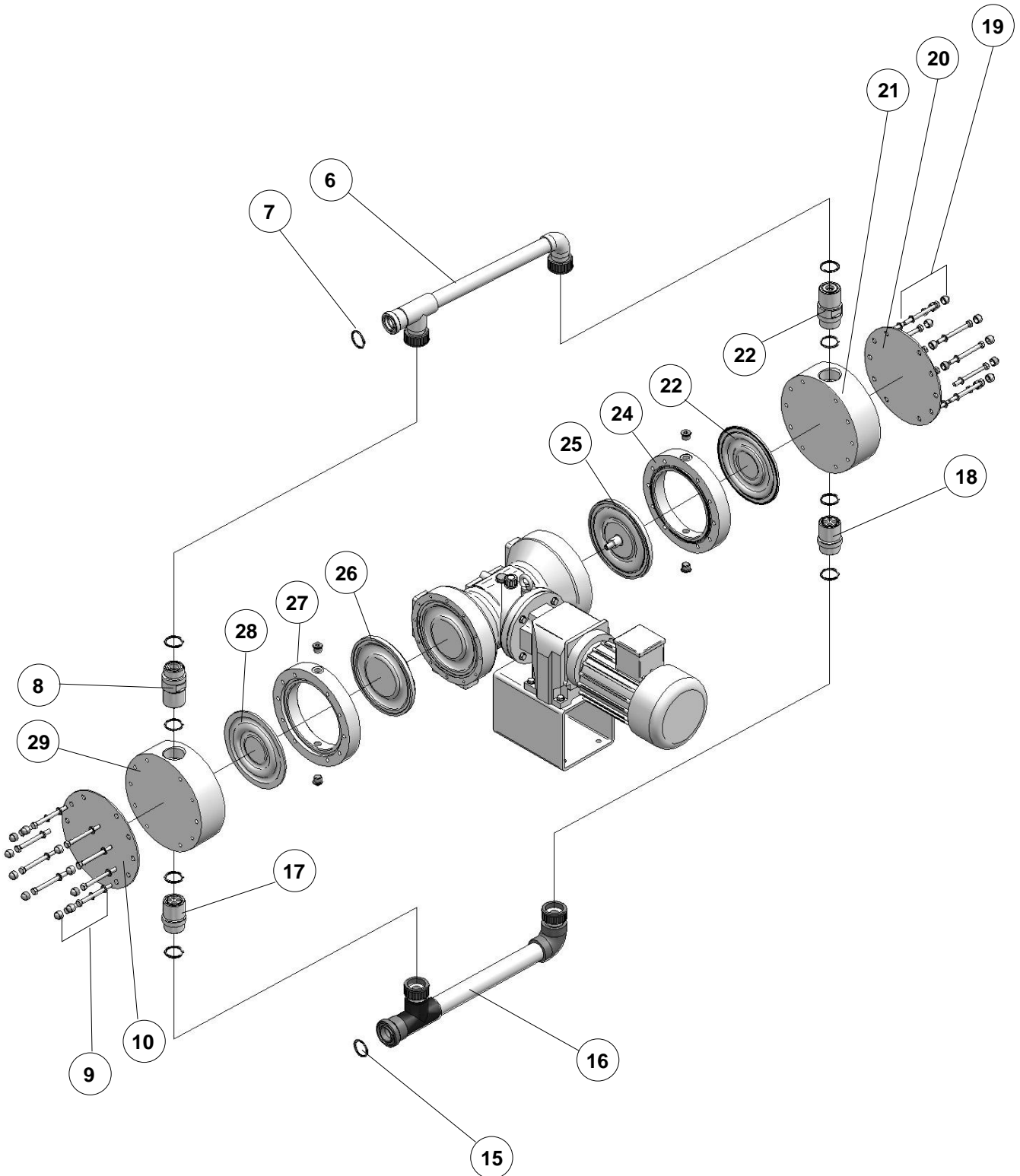

Fig. 31.2 Spare- and wearing parts (PVC-U)

Operating Instructions

Overview of the spare and wearing part kits (PVC-U)

Suction valve (kit)	
Item	Designation
18	Suction valve (incl. o-rings)
17	Suction valve (incl. o-rings)

Pressure valve (kit)	
Item	Designation
22	Pressure valve (incl. o-rings)
8	Pressure valve (incl. o-rings)

Suction side piping	
Item	Designation
16	Piping
15	O-Ring

Pressure side piping	
Item	Designation
6	Piping
7	O-Ring

Diaphragm kit (single diaphragm pump)	
Item	Designation
25	Drive diaphragm
26	Drive diaphragm

Diaphragm kit (double diaphragm pump)	
Item	Designation
22	Intermediate diaphragm
25	Drive diaphragm
	Buffer fluid
28	Intermediate diaphragm
26	Drive diaphragm
	Buffer fluid

Diaphragm ring kit (only for double diaphragm pump)	
Item	Designation
24	Diaphragm ring, complete
27	Diaphragm ring, complete

Pump body kit (plastic)	
Item	Designation
19	Screws, complete
20	Front plate
21	Pump body
9	Screws, complete
10	Front plate
29	Pump body

Operating Instructions

10.3.3 (stainless steel)

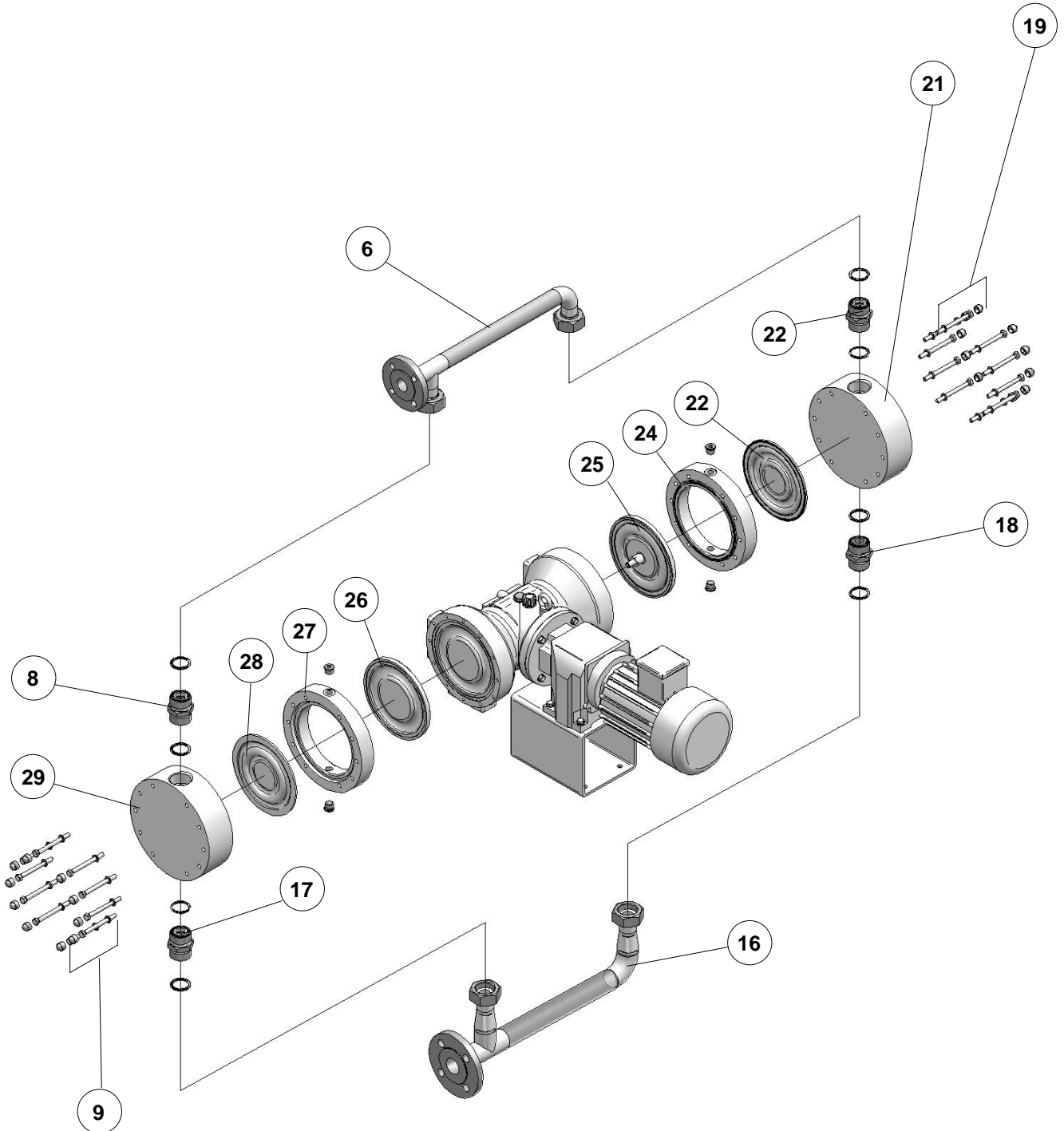

Fig. 31.3 Spare- and wearing parts (stainless steel)

Operating Instructions

Overview of the spare and wearing part kits (stainless steel)

Suction valve (kit)	
Item	Designation
18	Suction valve (incl. o-rings)
17	Suction valve (incl. o-rings)

Diaphragm kit (single diaphragm pump)	
Item	Designation
25	Drive diaphragm
26	Drive diaphragm

Pressure valve (kit)	
Item	Designation
22	Pressure valve (incl. o-rings)
8	Pressure valve (incl. o-rings)

Diaphragm kit (double diaphragm pump)	
Item	Designation
22	Intermediate diaphragm
25	Drive diaphragm
	Buffer fluid
28	Intermediate diaphragm
26	Drive diaphragm
	Buffer fluid

Suction side piping	
Item	Designation
16	Piping with fixed flange DN32

Diaphragm ring kit (only for double diaphragm pump)	
Item	Designation
24	Diaphragm ring, complete
27	Diaphragm ring, complete

Pressure side piping	
Item	Designation
6	Piping with fixed flange DN25

Pump body kit	
Item	Designation
19	Screws, complete
21	Pump body
9	Screws, complete
29	Pump body

Operating Instructions

10.4 Changing the Diaphragm

10.4.1 General

In order to ensure a correct function of the diaphragm pump and to fulfil the required safety and protective provisions – especially in explosion-hazardous areas – it is absolutely necessary to check and replace the diaphragms at regular intervals.

CAUTION !



For replacing the diaphragm, the system must be **depressurised!**

CAUTION !



Prior to replacing the diaphragm, empty the pump and, if necessary, rinse it with appropriate fluid in order to avoid contact with aggressive and/or toxic media!

- During maintenance or repair work, switch off the drive motor of the diaphragm pump and secure it against inadvertent or unauthorised reactivation.
- Take appropriate protective measures: wear protective clothing, breathing mask and safety goggles. Prepare a container with appropriate fluid right beside the pump for being able to remove splashes of the pumped medium.
- Use an appropriate detergent to rinse the diaphragm pump until no residues of the pumped medium remain in the pump body. Otherwise, pumped medium may leak when disassembling the pump. Collect the rinsed liquid in a safe way (avoid contact with it) and dispose of it in an environmentally compatible way. This measure is also necessary if the diaphragm pump should be returned for repair.

10.4.2 Single diaphragm pump

- Disassembly of suction joint:
 - Remove protective caps and hexagon nut with washers
 - Take off front plates
 - Remove suction joint. Take care that no suction joint parts fall off the pump body.
 - Remove o-rings
- Disassembly of pressure joint:
 - Remove protective caps, hexagon nut and washers
 - Take off front plates
 - Remove pressure joint.
 - Remove o-rings
- Pull stud bolts from pump body and remove

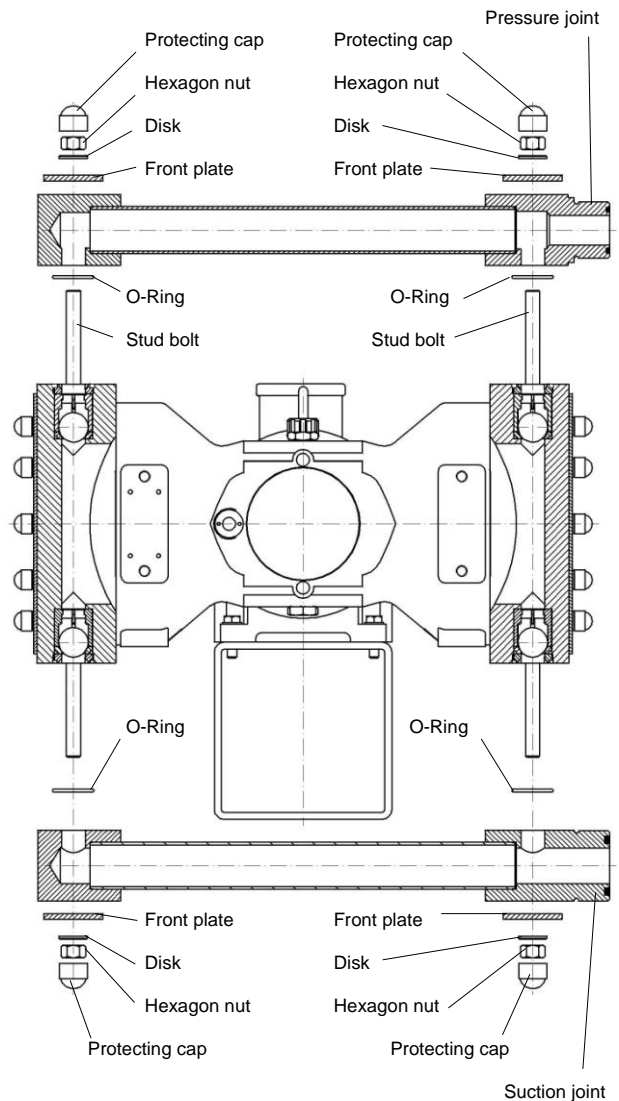

Fig. 32

Operating Instructions

- Remove protective caps
- Loosen hexagon screws at the pump body and remove along with washers
- Remove pump body and front plate (if installed) to the front. Take care that no suction joint parts fall off the pump body.
- The working diaphragm to be removed must be brought into a front position by turning the fan blade slowly.
- Screw the drive diaphragm out of the connecting rod

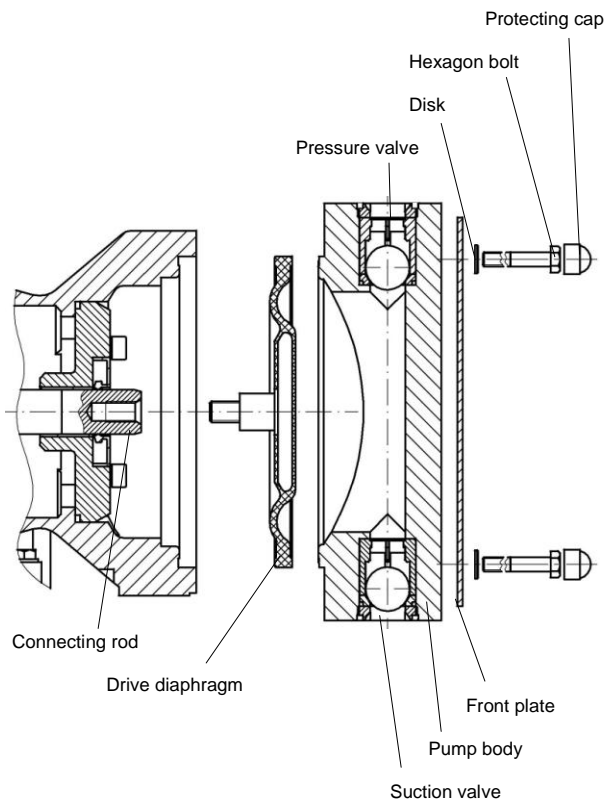

Fig. 33

Assemble the pump in reversed order

- Screw working diaphragms onto connecting rod

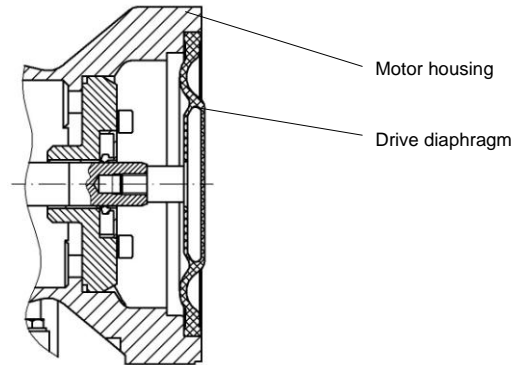

Fig. 34

- Move the drive diaphragms to the middle position by turning the fan blade of the drive motor (see Fig. 34).
- When assembling the pump body, please note: suction valve below, pressure valve above!
- Observe the tightening torques (see Chapter 8.1 / Table. 06)
- Mount suction and pressure joint. Use new o-rings. (see Fig. 32)
- Add the suction and pressure line and connect pump to the power supply. The diaphragm pump is then again ready for operation.

Operating Instructions

10.4.3 Double diaphragm pump

- Drain buffer fluid (by opening the screw plug).
- Disassemble the suction and pressure joint (see Chapter 10.4.2, Fig.32)
- Disassemble the pump body (see Chapter 11.4.2, Fig. 33) and screw out the drive intermediate diaphragm
- Remove the diaphragm ring to the front if the drive diaphragm is to be replaced, too

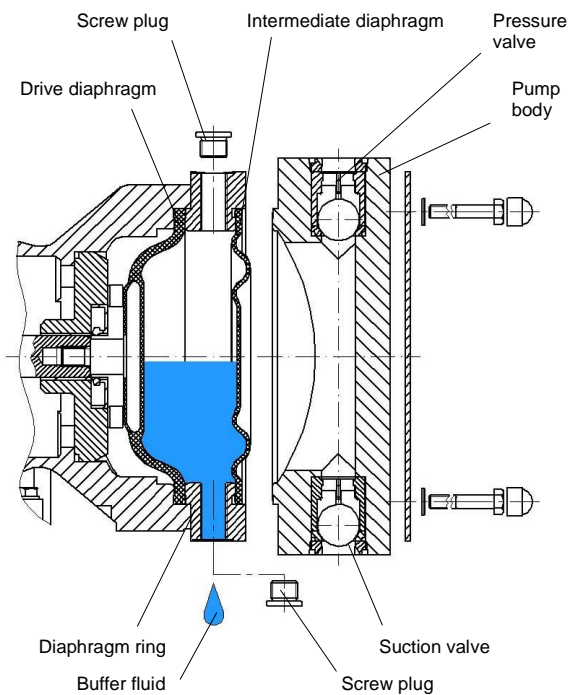

Fig. 35

Assemble the pump in reversed order

- Installation of the drive diaphragm (see Chapter 10.4.2)
- Insert intermediate diaphragm in the diaphragm ring (in case of a PTFE-laminated intermediate diaphragm the PTFE-coated side must point towards the pump body)
- When assembling the pump body, please note: suction valve below, pressure valve above!
- Observe the tightening torques (see Chapter 8.1/Tab.06)
- Move the drive diaphragm to the rear position by turning the fan blade of the drive motor (see Fig. 36).
- Fill buffer fluid in the diaphragm ring (type and quantity are indicated on the type plate)

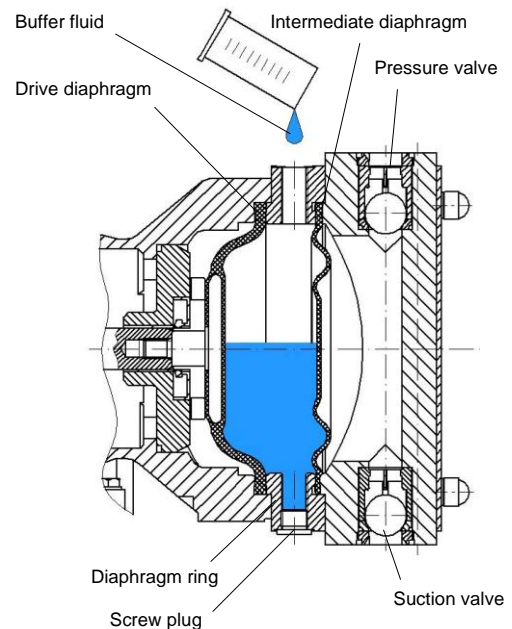

Fig. 36

Operating Instructions

- Move the drive diaphragm to the front by turning the fan blade of the drive motor until the buffer fluid level has reached the top edge of the filling hole.
- Screw in the screw plug(s) (see Fig. 37).
- Mount suction and pressure joint. Use new o-rings. (see Abb 37).

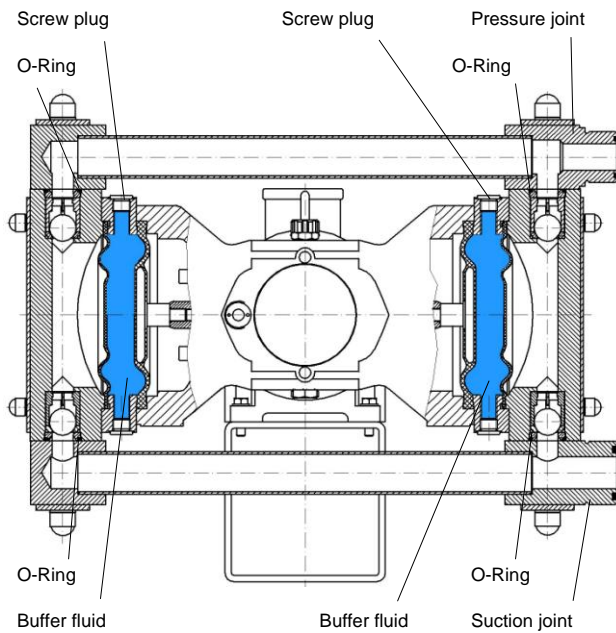

Fig. 37

Add the suction and pressure line and connect pump to the power supply. The diaphragm pump is then again ready for operation.

10.5 Oil change

- Check oil level at regular intervals (oil sight glass).

Perform an oil change once a year.
To do so, proceed as follows:

- Unscrew the venting screw.
- Prepare an appropriate container. Open the screw plug and drain off oil.

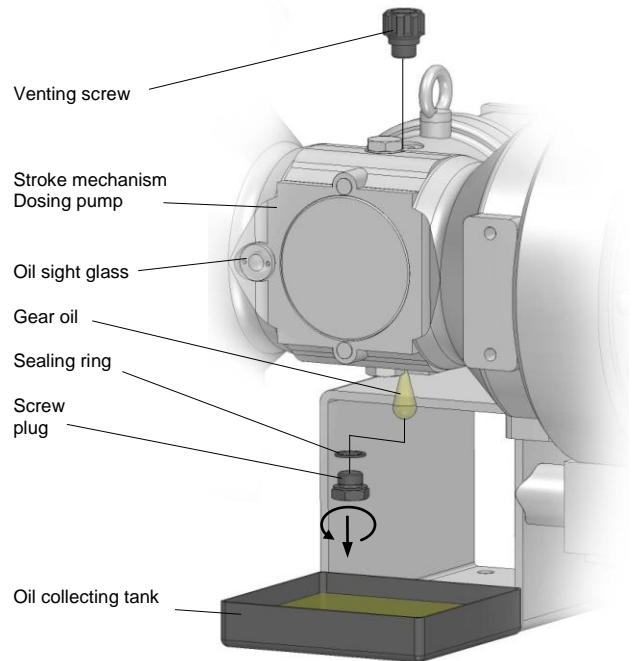

Fig. 38 . (Oil change)

Operating Instructions

- Close hole with screw plug (pay attention to the sealing ring!).
- Fill oil in threaded hole of the venting screw.
- For type and quantity of the gear oil, please see Chapter 11.1.
- Screw in venting screw.

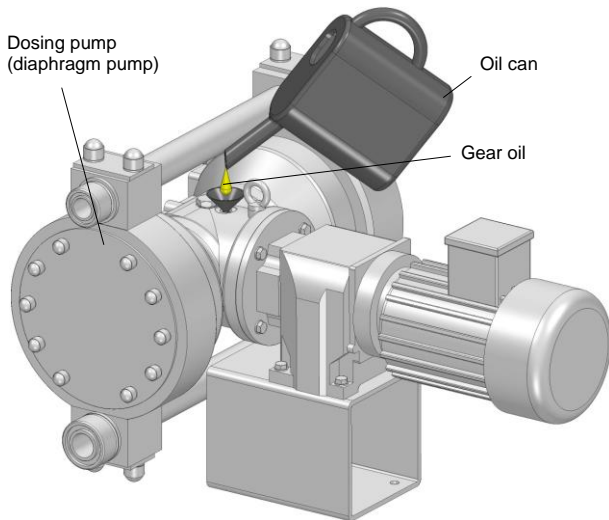

Fig. 39. (Filling gear oil)

11 Lubricants

11.1 Lubricant in the stroke mechanism

Pump type	Lubricant	Quantity
ZX... 411.3 – 2200 (e)	Gear oil SAE 90 DIN 51512	1,3 liter
ZX... 411.3 – 2600 (e)		
ZX... 411.3 – 3100 (e)		

Tab. 07 Lubricant in the stroke mechanism

11.2 Buffer fluid

Pump type	Buffer fluid	Quantity	
		PTFE intermediate diaphragm	PTFE-laminated intermediate diaphragm
ZX... 411.3 – 2200	Glycerin ¹⁾ DAB 87	525 cm ³	525 cm ³
ZX... 411.3 – 2600		525 cm ³	525 cm ³
ZX... 411.3 – 3100		525 cm ³	525 cm ³

Tab. 08 Buffer fluid

¹⁾ If no other specification is stated in the product description.

12 Fault analysis and corrective action

sera - products are sophisticated technical products which are only shipped after having been thoroughly tested and checked at our factory.

Should there be any faults, these can be detected and rectified easily and quickly if the steps in Table 09 are carried out.

Operating Instructions

Fault analysis and corrective action

Art der Störung											Possible cause	Fault clearance		
Diaphragm pump does not draw in	Diaphragm pump does not deliver	Delivery rate is not reached	Delivery height is not reached	Delivery rate fluctuates	Maximum delivery rate exceeded	Drive motor does not start	Pipe oscillates heavily	High noise development	Low service life of the drive diaphragm	Drive is overloaded	Damage in stroke mechanism / drive	Leakage on pump head		
●	●	●											Suction height too high	Reduce suction height or suction resistance
●	●	●		●									Suction line leaky	Check gaskets, tighten pipe connections
●	●					●						●	Shut-off valves in pipe closed	Open shut-off valves or check opening – check pump for damage
●	●	●											No conveying medium in store tank	Fill store tank
●	●	●	●	●									Pump valves leaky	Remove valves and clean
●	●		●	●									Pump valves (ball seats) damaged	Remove and clean valves, check function; replace valves if necessary
●	●												Pump valves incorrectly mounted or valve balls missing	Check installation position and completeness – replace missing parts or install correctly
●	●												Filter in suction line clogged	Clean filter
						●				●			Electric data of the drive motor do not match mains data	Check order data. Check electric installation. Adjust motor to mains data.
		●	●	●		●	●	●	●	●	●	●	Counter-pressure too high	Measure the pressure above the pressure valve if possible. Then compare to allowable counterpressure.
●	●	●	●	●									Foreign matter in pump valves	Remove and clean valves
				●	●								Pressure on suction side higher than at the end of the pressure line	Check geodetic conditions, install float valve or pressure keeping valve if necessary
		●	●	●	●	●	●	●	●	●	●	●	Acceleration height too high due to pipe geometry	Check acceleration height on suction- and pressure side and compare with design data – install a pulsation damper if necessary
									●			●	Material which is in contact with the medium not suitable for the pumped medium	Check whether the pumped medium corresponds with the design data and select other materials if necessary
●		●	●	●									Too high viscosity of the pumped medium	Check viscosity of the pumped medium and compare with the design data – reduce concentration or increase temperature if necessary
	●	●		●									Pumped medium outgasses in suction line	Check geodetic conditions and compare with the data of the pumped medium. Operate pump with suction side supply, reduce temperature of the pumped medium.
●													Air in suction line while pressure applied to the pressure valve ball	Vent pressure side
●	●	●	●	●								●	Pipe connections leaky	Tighten connection according to type of material. Be careful with plastic – risk of fracture
●	●	●										●	Temperature too low	Check flowability of the pumped medium. Temperature of pumped medium and ambient temperature must not fall below -10°C
●	●					●						●	Pumped medium frozen in pipe	Remove diaphragm pump and check for damage – increase temperature of the pumped medium
●	●	●	●	●					●			●	Diaphragm rupture	Replace diaphragm according to Chapter 10.4.

Table 09 Fault analysis and corrective action

Operating Instructions

13 Foreseeable misuse

The following misuse is assigned to the life cycles of the machine.

CAUTION !



Misuse can result in danger to the operating personnel!

13.1 Transport

- Tipping behavior during transport, loading and unloading ignored.
- Weight for lifting underestimated.

13.2 Assembly and installation

- Power supply not fuse protected (no fuse/fuse too large, power supply not conforming to standards).
- No or improper fastening material of the pump.
- Improper connection of the pressure pipes, wrong material i.e. PTFE tape and unsuitable connection pieces.
- Liquid pipes confused.
- Threads overturned/damaged.
- Pipes bent during connection in order to compensate for alignment errors.
- Supply voltage connected without earthed conductor.
- Socket for safe disconnection of the power supply difficult to reach.
- Wrong connecting cables for supply voltage (cross-section too small, wrong insulation).
- Parts damaged (e.g. vent valve, flow meter broken off).
- Wrongly dimensioned pressure and suction pipe.
- Incorrect dimensioned and improperly fastened pump panel (panel broken off).

13.3 Start-up

- Cover on vent openings (e.g. motor).
- Suction or pressure pipes closed (i.e. foreign matters, particle size, stop valves).
- Start-up with damaged system.

13.4 Operation

- Fault message ignored → faulty dosing / process error.
- Pipes hit, pulsation damper not used → damage to the pipes, medium is leaking.
- Pumped medium contains particles or is contaminated.
- External fuse bridged → no cut off in case of an error.
- Ground wire removed → no cut off by fuse in case of an error, supply voltage directly at the housing.
- Insufficient lighting of the working place.
- No supervision of leakages → MBE opening.
- Diaphragm rupture is not indicated when the MBE plug was disconnected. Medium can escape into the environment through the vent hole "Danger to the operator and the environment".
- Arbitrary modification of the pump (valves, internal fuse, ...).
- Suction height too high, pump capacity too low → process error.

13.5 Maintenance/Repair

- Works carried out which are not described in the operating instructions (works on the stroke mechanism and the built-in pump, electronics opened).
- Prescribed maintenance schedules ignored.
- Use of wrong spare parts/oils (e.g. no **sera** original spare parts, wrong viscosity).
- Improper mounting of spare and wearing parts (e.g. wrong tightening torque for pump body).
- Oil level not checked.
- Use of cables with damaged insulation.
- No shut down / no protection against a restart before maintenance work.
- Pumped medium or utilities during an oil change insufficiently removed.
- Restart without sufficient fastening.
- Valves confused.
- Sensor pipes confused.
- Pipes not connected (e.g. suction- and pressure pipes, gas pipes).
- Gaskets damaged, medium is leaking.
- Gaskets not fitted, medium is leaking.
- Wearing of unsuitable protective clothing / no protective clothing at all.
- Operation of an uncleaned system.
- Pumped medium contaminated with oil.
- Poorly ventilated room.

Operating Instructions

13.6 Cleaning

- Wrong rinsing medium (material changed, reaction with the medium).
- Wrong cleaning agent (material changed, reaction with the medium).
- Cleaning agent remains in the system (material changed, reaction with the medium).
- Protective clothing insufficient or missing.
- Use of unsuitable cleaning utensils (material changed, mechanical damage by high pressure cleaner).
- Untrained personnel.
- Vent openings clogged.
- Parts torn off.
- Sensors damaged.
- Non-observance of the safety data sheet.
- Control elements actuated.
- Poorly ventilated room.

13.7 Shut-down

- Pumped medium not completely removed.
- Disassembly of pipes with the pump running/with residual pressure.
- Disconnection of the electrical connections in a wrong sequence (ground wire first).
- Disconnection from the power supply not ensured → danger through electricity.
- Poorly ventilated room.

13.8 Disassembly

- Residues of the pumped medium and utilities in the system.
- Use of wrong disassembly tools.
- Wrong or no protective clothing at all.
- Poorly ventilated room.

13.9 Disposal

- Improper disposal of the pumped medium, utilities and materials.
- No marking of hazardous media.

14 Shut-down

Switch the diaphragm pump off.

Rinse pump head to remove the pumped medium and make sure that the detergent is suitable for the pumped medium and the material of the pump head.

15 Disposal

Shut-down system. Please see "Shut-down".

15.1 Dismantling and transport

- Remove all fluid residues, clean thoroughly, neutralize and decontaminate.
- Package unit and ship.

15.2 Complete disposal

- Remove all fluid residues from unit.
- Drain off lubricants and dispose of according to regulations!
- Dismount materials and send them to a suitable waste disposal company!

CAUTION !



The consignor is responsible for damage caused by leaking lubricants and fluids!

Operating Instructions

Notes

Operating Instructions

Notes

Operating Instructions

Notes

Operating Instructions

Notes

