

# GEMÜ C60 CleanStar PFA

Pneumatically operated diaphragm valve with PFA valve body

EN

## Operating instructions



All rights including copyrights or industrial property rights are expressly reserved.

Keep the document for future reference.

© GEMÜ Gebr. Müller Apparatebau GmbH & Co. KG  
01.07.2022

---

## Contents

<b>1</b>	<b>General information</b>	<b>4</b>
1.1	Information	4
1.2	Symbols used	4
1.3	Definition of terms	4
1.4	Warning notes	4
<b>2</b>	<b>Safety information</b>	<b>5</b>
<b>3</b>	<b>Product description</b>	<b>5</b>
3.1	Construction	5
3.2	Description	5
3.3	Function	5
3.4	Product label	5
<b>4</b>	<b>Correct use</b>	<b>7</b>
<b>5</b>	<b>Order data C60 PFA</b>	<b>8</b>
5.1	Order data - body configuration - 2/2-way body (code D)	8
<b>6</b>	<b>Technical data C60 PFA</b>	<b>10</b>
6.1	Medium	10
6.2	Temperature	10
6.3	Pressure	10
6.4	Product conformities	12
6.5	Mechanical data	12
<b>7</b>	<b>Dimensions C60 PFA</b>	<b>12</b>
7.1	2/2-way valves (code D)	12
7.2	Mounting dimensions	13
<b>8</b>	<b>Manufacturer's information</b>	<b>14</b>
8.1	Delivery	14
8.2	Transport	14
8.3	Storage	14
8.4	Tools	14
8.5	Opening the packaging	14
<b>9</b>	<b>Installation in piping</b>	<b>14</b>
9.1	Preparing for installation	14
9.2	Installation with butt weld spigots	15
9.3	After the installation	15
9.4	Operation	15
<b>10</b>	<b>Pneumatic connections</b>	<b>16</b>
10.1	Control function	16
10.2	Connecting the control medium	16
<b>11</b>	<b>Commissioning</b>	<b>16</b>
<b>12</b>	<b>Troubleshooting</b>	<b>17</b>
<b>13</b>	<b>Inspection and maintenance</b>	<b>18</b>
<b>14</b>	<b>Removal from piping</b>	<b>18</b>
<b>15</b>	<b>Disposal</b>	<b>18</b>
<b>16</b>	<b>Returns</b>	<b>18</b>
<b>17</b>	<b>Declaration of Incorporation according to 2006/42/EC (Machinery Directive)</b>	<b>19</b>
<b>18</b>	<b>Declaration of conformity according to 2014/68/EU (Pressure Equipment Directive)</b>	<b>20</b>

## 1 General information

### 1.1 Information

- The descriptions and instructions apply to the standard versions. For special versions not described in this document the basic information contained herein applies in combination with any additional special documentation.
- Correct installation, operation, maintenance and repair work ensure faultless operation of the product.
- Should there be any doubts or misunderstandings, the German version is the authoritative document.
- Contact us at the address on the last page for staff training information.

### 1.2 Symbols used

The following symbols are used in this document:

Symbol	Meaning
●	Tasks to be performed
▶	Response(s) to tasks
-	Lists

### 1.3 Definition of terms

#### Working medium

The medium that flows through the GEMÜ product.

#### Control function

The possible actuation functions of the GEMÜ product.

#### Control medium

The medium whose increasing or decreasing pressure causes the GEMÜ product to be actuated and operated.

### 1.4 Warning notes

Wherever possible, warning notes are organised according to the following scheme:

SIGNAL WORD	
Possible symbol for the specific danger	<p>Type and source of the danger</p> <ul style="list-style-type: none"> <li>▶ Possible consequences of non-observance.</li> <li>● Measures for avoiding danger.</li> </ul>

Warning notes are always marked with a signal word and sometimes also with a symbol for the specific danger.

The following signal words and danger levels are used:





⚠ DANGER	
	<p><b>Imminent danger!</b></p> <ul style="list-style-type: none"> <li>▶ Non-observance can cause death or severe injury.</li> </ul>

⚠ WARNING	
	<p><b>Potentially dangerous situation!</b></p> <ul style="list-style-type: none"> <li>▶ Non-observance can cause death or severe injury.</li> </ul>

⚠ CAUTION	
	<p><b>Potentially dangerous situation!</b></p> <ul style="list-style-type: none"> <li>▶ Non-observance can cause moderate to light injury.</li> </ul>

NOTICE	
	<p><b>Potentially dangerous situation!</b></p> <ul style="list-style-type: none"> <li>▶ Non-observance can cause damage to property.</li> </ul>

The following symbols for the specific dangers can be used within a warning note:

Symbol	Meaning
	Danger of explosion
	Corrosive chemicals!
	Hot plant components!
	Vapor fumes from PFA welding can cause health related issues!

## 2 Safety information

The safety information in this document refers only to an individual product. Potentially dangerous conditions can arise in combination with other plant components, which need to be considered on the basis of a risk analysis. The operator is responsible for the production of the risk analysis and for compliance with the resulting precautionary measures and regional safety regulations.

The document contains fundamental safety information that must be observed during commissioning, operation and maintenance. Non-compliance with these instructions may cause:

- Personal hazard due to electrical, mechanical and chemical effects.
- Hazard to nearby equipment.
- Failure of important functions.
- Hazard to the environment due to the leakage of dangerous materials.

The safety information does not take into account:

- Unexpected incidents and events, which may occur during installation, operation and maintenance.
- Local safety regulations which must be adhered to by the operator and by any additional installation personnel.

### Prior to commissioning:

1. Transport and store the product correctly.
2. Do not paint the bolts and plastic parts of the product.
3. Carry out installation and commissioning using trained personnel.
4. Provide adequate training for installation and operating personnel.
5. Ensure that the contents of the document have been fully understood by the responsible personnel.
6. Define the areas of responsibility.
7. Observe the safety data sheets.
8. Observe the safety regulations for the media used.

### During operation:

9. Keep this document available at the place of use.
10. Observe the safety information.
11. Operate the product in accordance with this document.
12. Operate the product in accordance with the specifications.
13. Maintain the product correctly.
14. Do not carry out any maintenance work and repairs not described in this document without consulting the manufacturer first.

### In cases of uncertainty:

15. Consult the nearest GEMÜ sales office.

## 3 Product description

### 3.1 Construction



No.	Name	Materials
1	Optical position indicator	
2	Actuator	PVDF (housing)
3	Pneumatic connections	
4	Actuator union nut	PVDF
5	Mounting lugs	
6	Leak detection hole	
7	Valve body	PFA
	Diaphragm (internal)	PTFE (media wetted) / EPDM

### 3.2 Description

The GEMÜ C60 CleanStar® ultra pure 2/2-way diaphragm valve has a plastic piston actuator and is pneumatically operated. An integrated optical position indicator is standard. All media wetted parts are made of PFA or PTFE. This High Purity version of the CleanStar® series complies with the strictest purity standards and boasts high chemical resistance. As such, it is often used at the supply and distribution level in semiconductor factories.

### 3.3 Function

The GEMÜ CleanStar® C60 diaphragm valve has been designed for installation in piping systems. It can be closed or opened by a control medium, which is how it controls the flow.

### 3.4 Product label

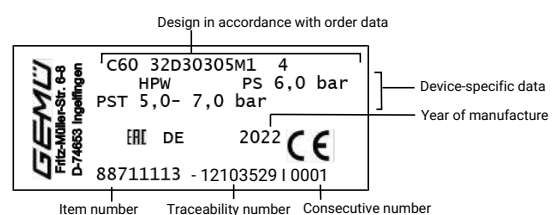

The product label is located on the actuator. Product label data (example):

The month of manufacture is encoded in the traceability number and can be obtained from GEMÜ. The product was manufactured in Germany.

The operating pressure stated on the product label applies to a media temperature of 20 °C. The product can be used up to the maximum stated media temperature. You can find the pressure/temperature correlation in the technical data.

#### 4 Correct use

##### **DANGER**



##### **Danger of explosion**

- ▶ Risk of death or severe injury.
- Do **not** use the product in potentially explosive zones.

##### **WARNING**

##### **Improper use of the product**

- ▶ Risk of severe injury or death.
- ▶ Manufacturer liability and guarantee will be void.
- Only use the product in accordance with the operating conditions specified in the contract documentation and in this document.

The product is designed for installation in piping systems and for controlling a working medium.

The product is not intended for use in potentially explosive areas.

- Use the product in accordance with the technical data.

## 5 Order data C60 PFA

### 5.1 Order data - body configuration - 2/2-way body (code D)

#### Order codes

The order data provide an overview of standard configurations.

Please check the availability before ordering. Other configurations available on request.

1 Type	Code
Diaphragm valve, pneumatically operated, plastic piston actuator, optical position indicator	C60

2 Connection size	Code
1 1/2", international code: 24	24
2", international code: 32	32

3 Body configuration	Code
2/2-way body	D

4 Connection type	Code
Pipe	
Imperial butt weld spigot	30

5 Valve body material	Code
PFA, perfluoroalkoxy	30

6 Diaphragm material	Code
PTFE/EPDM two-piece	5M

7 Control function	Code
Normally closed (NC)	1
Normally open (NO)	2
Double acting (DA)	3

8 Actuator version	Code
Standard version	
Actuator size 4	4

9 High Purity version	Code
High Purity white	HPW

**Order example**

Ordering option	Code	Description
1 Type	C60	Diaphragm valve, pneumatically operated, plastic piston actuator, optical position indicator
2 Connection size	32	2", international code: 32
3 Body configuration	D	2/2-way body
4 Connection type	30	Imperial butt weld spigot
5 Valve body material	30	PFA, perfluoroalkoxy
6 Diaphragm material	5M	PTFE/EPDM two-piece
7 Control function	1	Normally closed (NC)
8 Actuator version	4	Actuator size 4
9 High Purity version	HPW	High Purity white

## 6 Technical data C60 PFA

### 6.1 Medium

**Working medium:** Corrosive, inert, gaseous and liquid media – in particular high-purity media – which have no negative impact on the physical and chemical properties of the body and diaphragm material.

### 6.2 Temperature

**Media temperature:** Valve body material PFA (code 30): -10 – 100 °C  
Observe pressure/temperature diagram

**Ambient temperature:** 0 – 60 °C

**Storage temperature:** 0 – 40 °C

### 6.3 Pressure

**Operating pressure:** 0 – 6 bar

**Pressure/temperature diagram:**

**Valve body material PFA (code 30)**

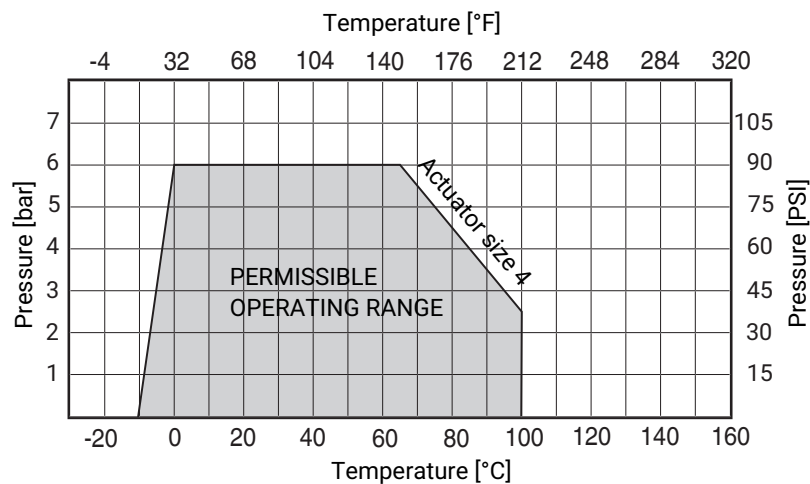

**Note:** The Pressure/Temperature diagram is only an aid. The data refers to water as a working medium. A change of operating conditions or other media may result in deviations. In case of doubt, it is advisable to test the behaviour of the material under the definitive operating conditions in a test installation. Temperatures below 0 °C can have a negative influence on the actuation speed.

**Kv values:**

#### Body configuration - 2/2-way body (code D)

Actuator size (code)	Connection size	Connection on both sides
	X, Z	Pipe connection
4	1½"	1225.0
	2"	1225.0

Kv values in l/min

**Vacuum:** 400 mbar absolute

The service life of the valve may be affected if exposed to a greater vacuum or when valves are installed on the pump suction side.

## Pneumatic actuator

## Control pressure:

Control function	Actuator size	Control pressure
1	4	5 - 7 bar
2, 3	4	max. 4.5 bar

## Control pressure / operating pressure characteristics:

## Control function 1 - normally closed (NC)

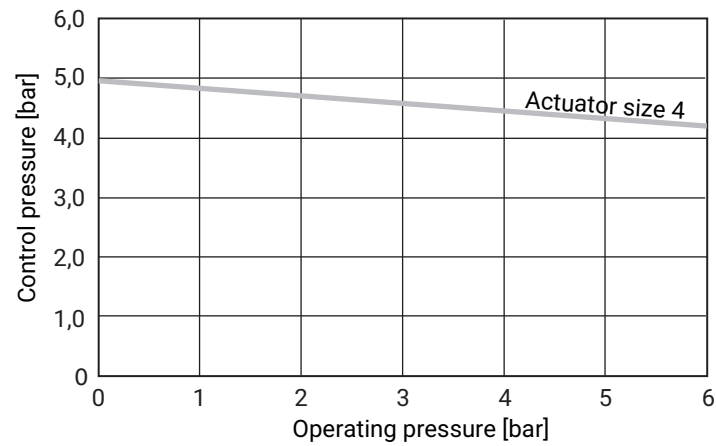

## Control function 2 - normally open (NO)

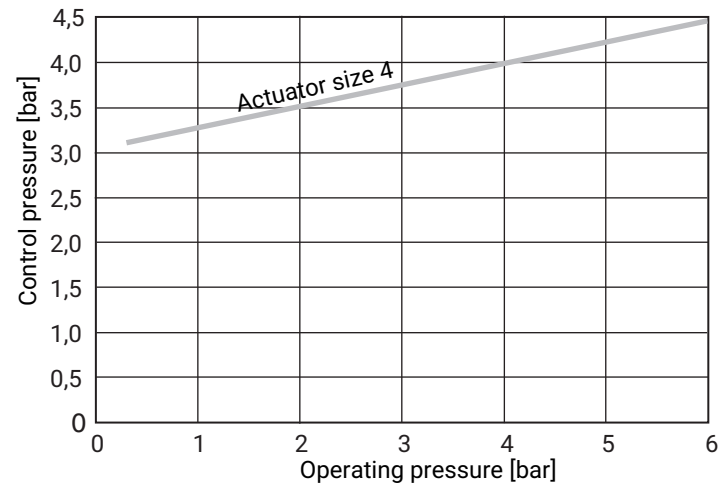

## Filling volume:

Actuator size	Control function			
	Normally closed (NC)	Normally open (NO)	Double acting (closed) (DA)	Double acting (open) (DA)
4	146.0	794.0	146.0	956.0

Filling volume in cm<sup>3</sup>

**6.4 Product conformities**

**Machinery Directive:** 2006/42/EC  
**Food:** FDA  
**EAC:** The product is certified according to EAC.

**6.5 Mechanical data**

**Flow direction:** Optional

**7 Dimensions C60 PFA**

**7.1 2/2-way valves (code D)**

**7.1.1 Butt weld spigot (code 30)**

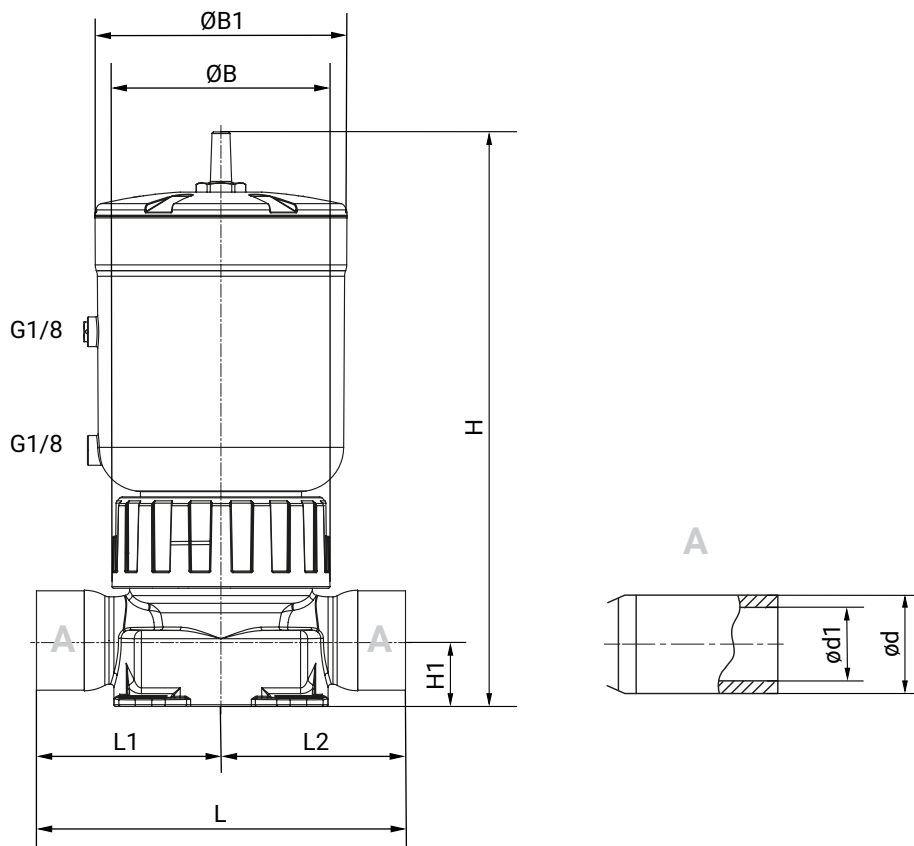

Actuator size <sup>1)</sup>	Connec- tion size	ØB	ØB1	H	H1	L	L1	L2	Spigot (A)	
									ød	ød1
4	1½"	132.3	153.0	349.6	40.0	194.0	97.0	97.0	48.3	40.9
4	2"	132.3	153.0	349.6	40.0	224.0	112.0	112.0	60.3	52.3

Dimensions in mm

1) **Actuator version**  
 Code 4: Actuator size 4

## 7.2 Mounting dimensions

2/2-way valve (code D)

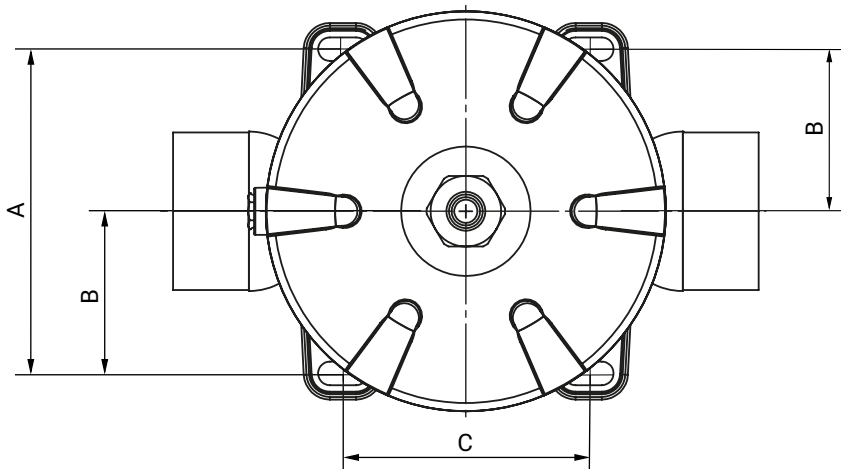

2/2-way valves (code D)

Actuator size	$\varnothing d$	A	B	C
4	9.0	124.0	62.0	104.0

Dimensions in mm

### 7.2.1 Mounting holes, round and slotted hole

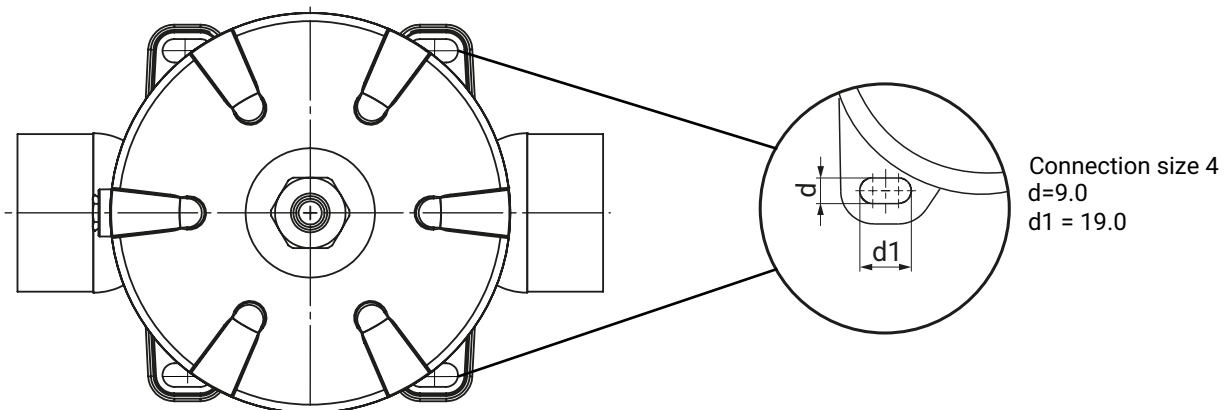

Dimensions in mm

## 8 Manufacturer's information

### 8.1 Delivery

- Check that all parts are present and check for any damage immediately upon receipt.

The product's performance is tested at the factory. The scope of delivery is apparent from the dispatch documents and the design from the order number.

Control function	Function	Condition as supplied to customer
1	Normally closed (NC)	closed
2	Normally open (NO)	open
3	Double acting (DA)	undefined

### 8.2 Transport

1. Only transport the product by suitable means. Do not drop. Handle carefully.
2. After the installation dispose of transport packaging material according to relevant local or national disposal regulations / environmental protection laws.

### 8.3 Storage

1. Store the product free from dust and moisture in its original packaging.
2. Avoid UV rays and direct sunlight.
3. Do not exceed the maximum storage temperature (see chapter "Technical data").
4. Do not store solvents, chemicals, acids, fuels or similar fluids in the same room as GEMÜ products and their spare parts.

### 8.4 Tools

1. The tools required for installation and assembly are not included in the scope of delivery.
2. Use appropriate, functional and safe tools.

### 8.5 Opening the packaging

The product is sealed in two plastic bags and packaged in a box.

#### CAUTION

**Do not open the box in the cleanroom!**

- ▶ Contamination risk!

#### CAUTION

**Open the box carefully and outside the cleanroom. Do not use a knife or sharp object. Avoid tearing open the outer plastic bag.**

- ▶ Contamination risk!
- ▶ Reduces product purity!

The box contains the double sealed diaphragm valve.

#### CAUTION

**Avoid tearing open the outer plastic bag. Only open the internal Nylon-PE plastic bag in the cleanroom immediately prior to installation.**

- ▶ Contamination risk!
- ▶ Reduces product purity!

### 9 Installation in piping

#### CAUTION

**Fixing with suitable media resistant plastic bolts (not included in the scope of delivery)**

- ▶ Corrosion and contamination when using metal bolts.

#### 9.1 Preparing for installation

#### WARNING

**The equipment is subject to pressure!**

- ▶ Risk of severe injury or death.
- Depressurize the plant.
- Completely drain the plant.

#### WARNING



**Corrosive chemicals!**

- ▶ Risk of caustic burns.
- Wear suitable protective gear.
- Completely drain the plant.

#### CAUTION



**Hot plant components!**

- ▶ Risk of burns.
- Only work on plant that has cooled down.

#### CAUTION

**Exceeding the maximum permissible pressure.**

- ▶ Damage to the product.
- Provide precautionary measures against exceeding the maximum permitted pressures caused by pressure surges (water hammer).

#### CAUTION

**Use as step.**

- ▶ Damage to the product.
- ▶ Risk of slipping-off.
- Choose the installation location so that the product cannot be used as a foothold.
- Do not use the product as a step or a foothold.

**NOTICE****Suitability of the product!**

- ▶ The product must be appropriate for the piping system operating conditions (medium, medium concentration, temperature and pressure) and the prevailing ambient conditions.

**NOTICE****Tools**

- ▶ The tools required for installation and assembly are not included in the scope of delivery.
  - Use appropriate, functional and safe tools.
1. Ensure the product is suitable for the relevant application.
  2. Check the technical data of the product and the materials.
  3. Keep appropriate tools ready.
  4. Wear appropriate protective gear, as specified in the plant operator's guidelines.
  5. Observe appropriate regulations for connections.
  6. Have installation work carried out by trained personnel.
  7. Shut off plant or plant component.
  8. Secure plant or plant component against recommissioning.
  9. Depressurize the plant or plant component.
  10. Completely drain the plant (or plant component) and let it cool down until the temperature is below the media vaporization temperature and cannot cause scalding.
  11. Decontaminate, rinse and ventilate the plant or plant component properly.
  12. Lay piping so that the product is protected against transverse and bending forces, and also from vibrations and tension.
  13. Only mount the product between matching aligned pipes (see following chapters).
  14. Flow direction and installation position are optional.

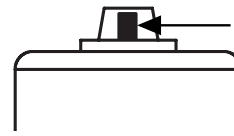

Valve open

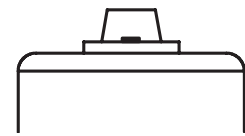

Valve closed

**9.2 Installation with butt weld spigots****⚠ DANGER****Vapor fumes from PFA welding can cause health related issues!**

- ▶ Risk of damage to respiratory tracts, caustic burning/poisoning.
- Weld PFA components in a well-ventilated area.
- Wear protective gear.
- Breathing masks are recommended.

**Adhere to good welding practices!**

**Observe appropriate regulations for connections!**

**9.3 After the installation**

- Re-attach or reactivate all safety and protective devices.

**9.4 Operation**

**Optical position indicator**

## 10 Pneumatic connections

### 10.1 Control function

The following control functions are available:

#### Control function 1

##### Normally closed (NC):

Valve resting position: closed by spring force. Activation of the actuator (connector 2) opens the valve. When the actuator is vented, the valve is closed by spring force.

#### Control function 2

##### Normally open (NO):

Valve resting position: opened by spring force. Activation of the actuator (connector 4) closes the valve. When the actuator is vented, the valve is opened by spring force.

#### Control function 3

##### Double acting (DA):

Valve resting position: no defined normal position. The valve is opened and closed by activating the respective control medium connectors (connector 2: open / connector 4: close).

Control function	Connections	
	2	4
1 (NC)	+	-
2 (NO)	-	+
3 (DA)	+	+

+ = available / - = not available  
(see images for connectors 2 / 4)

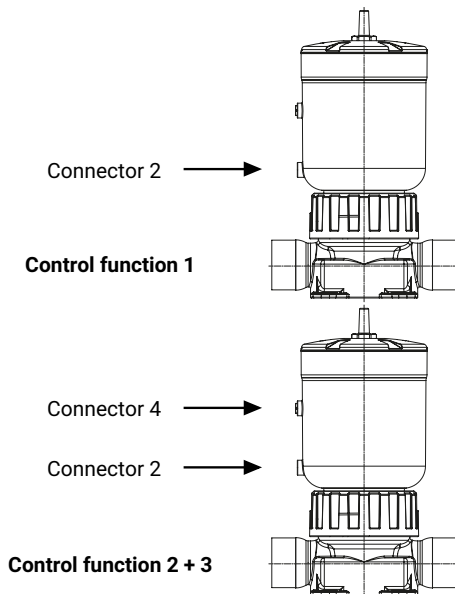

### 10.2 Connecting the control medium

1. Use suitable connectors.
2. Connect the control medium lines tension-free and without any bends or knots.

Thread size of the control medium connectors: G1/8

Control function		Connections
1	Normally closed (NC)	2: Control medium (open)
2	Normally open (NO)	4: Control medium (close)
3	Double acting (DA)	2: Control medium (open) 4: Control medium (close)

See images for connector 2 / 4

## 11 Commissioning

**WARNING**



**Corrosive chemicals!**

- ▶ Risk of caustic burns.
- Wear suitable protective gear.
- Completely drain the plant.

**CAUTION**

**Leakage**

- ▶ Emission of dangerous materials.
- Provide precautionary measures against exceeding the maximum permitted pressures caused by pressure surges (water hammer).

**CAUTION**

**Cleaning agent**

- ▶ Damage to the GEMÜ product.
- The plant operator is responsible for selecting the cleaning material and performing the procedure.

1. Check the tightness and the function of the product (close and reopen the product).
2. Flush the piping system of new plant and following repair work (the product must be fully open).  
⇒ Harmful foreign matter has been removed.  
⇒ The product is ready for use.
3. Commission the product.
4. Commissioning of operators in accordance with the enclosed instructions.

## 12 Troubleshooting

Error	Error cause	Troubleshooting
Control medium is escaping from connector 4* (control function NC) or from connector 2* (control function NO) (see the "Control functions" chapter)	Piston seal leaking	Replace product
Control medium escaping from leak detection hole* (only with NC control function)	Spindle seal leaking	Replace product and check control medium for impurities
Working medium escaping from leak detection hole	Shut off diaphragm is defective	Replace product
The product does not open or does not open fully	Control pressure too low (for control function NC)	Operate the product with the control pressure specified in the datasheet
	Pilot valve faulty	Check and replace pilot valve
	Control medium not connected	Connect control medium
	Lower spindle seal or piston seal leaking	Replace product
	Actuator spring faulty (for control function NO)	Replace the actuator
The product is leaking downstream (does not close or does not close fully)	Operating pressure too high	Operate the product with operating pressure specified in datasheet
	Foreign matter between shut off diaphragm and valve body	Remove the actuator, remove foreign matter, check diaphragm and valve body for potential damage, replace actuator if necessary
	Valve body leaks or is damaged	Check valve body for potential damage, replace valve body if necessary
	Shut off diaphragm is defective	Check shut off diaphragm for potential damage, replace diaphragm if necessary
	Actuator spring faulty (for control function NC)	Replace actuator
The product leaks downstream (does not close or does not close fully)	Control pressure too low (for control function NO and control function DA)	Operate the product with the control pressure specified in the datasheet
Connection between valve body and piping leaking	Incorrect installation	Check installation of valve body in piping
Control medium escaping from transparent cap** (with NO control function and DA control function)	Upper spindle seal leaking	Replace product

\* see the "Construction" chapter

### 13 Inspection and maintenance

#### WARNING

##### The equipment is subject to pressure!

- ▶ Risk of severe injury or death.
- Depressurize the plant.
- Completely drain the plant.

#### CAUTION



##### Hot plant components!

- ▶ Risk of burns.
- Only work on plant that has cooled down.

#### CAUTION

##### Use of incorrect spare parts!

- ▶ Damage to the GEMÜ product.
- ▶ Manufacturer liability and guarantee will be void.
- Use only genuine parts from GEMÜ.

#### NOTICE

##### Exceptional maintenance work!

- ▶ Damage to the GEMÜ product.
- Any maintenance work and repairs not described in these operating instructions must not be performed without consulting the manufacturer first.

The operator must carry out regular visual examination of the GEMÜ products depending on the operating conditions and the potential danger in order to prevent leakage and damage.

The product also must be disassembled and checked for wear in the corresponding intervals.

1. Have servicing and maintenance work performed by trained personnel.
2. Wear appropriate protective gear as specified in plant operator's guidelines.
3. Shut off plant or plant component.
4. Secure plant or plant component against recommissioning.
5. Depressurize the plant or plant component.
6. Actuate GEMÜ products which are always in the same position four times a year.

### 14 Removal from piping

1. Remove in reverse order to installation.
2. Deactivate the control medium.
3. Disconnect the control medium line(s).
4. Disassemble the product. Observe warning notes and safety information.

### 15 Disposal

1. Pay attention to adhered residual material and gas diffusion from penetrated media.
2. Dispose of all parts in accordance with the disposal regulations/environmental protection laws.

### 16 Returns

Legal regulations for the protection of the environment and personnel require that the completed and signed return delivery note is included with the dispatch documents. Returned goods can be processed only when this note is completed. If no return delivery note is included with the product, GEMÜ cannot process credits or repair work but will dispose of the goods at the operator's expense.

1. Clean the product.
2. Request a return delivery note from GEMÜ.
3. Complete the return delivery note.
4. Send the product with a completed return delivery note to GEMÜ.

**17 Declaration of Incorporation according to 2006/42/EC (Machinery Directive)**



**Declaration of incorporation**

according to the EC Machinery Directive 2006/42/EC, Annex II, 1.B for partly completed machinery

We, GEMÜ Gebr. Müller Apparatebau GmbH & Co. KG  
Fritz-Müller-Straße 6-8  
74653 Ingelfingen-Criesbach, Germany

declare that the following product complies with the essential requirements of the Machinery Directive 2006/42/EC.

**Product:** GEMÜ C60 CleanStar  
**Versions:** Actuator size 4  
**Product name:** Pneumatically operated diaphragm valve  
**From production date:** 2022-05-15  
**Essential requirements of the Machinery Directive 2006/42/EC** 1.1.3., 1.1.5., 1.2.1., 1.3., 1.3.2., 1.3.3., 1.3.4., 1.3.7., 1.3.9., 1.5.3., 1.5.5., 1.5.6., 1.5.7., 1.5.8., 1.5.9., 1.6.5.;  
**Technical standard used in parts:** ISO 12100

We also declare that the specific technical documentation has been compiled in accordance with part B of Annex VII.

The manufacturer, or their authorised representative, undertakes to transmit, in response to a reasoned request, relevant documents on the partly completed machinery to the national authorities. This transmission takes place electronically.

Authorised documentation officer: GEMÜ Gebr. Müller Apparatebau GmbH & Co. KG  
Fritz-Müller-Straße 6-8  
74653 Ingelfingen-Criesbach, Germany

This does not affect the industrial property rights.

**Important note! The valve must only be commissioned in machinery that comply with the provisions of this Directive.**

M. Barghoorn  
Head of Global Technics

Ingelfingen, 2022-05-09

**18 Declaration of conformity according to 2014/68/EU (Pressure Equipment Directive)**



**Declaration of conformity**

in accordance with 2014/68/EU (Pressure Equipment Directive)

We, GEMÜ Gebr. Müller Apparatebau GmbH & Co. KG  
Fritz-Müller-Straße 6-8  
74653 Ingelfingen-Criesbach, Germany

declare that the product listed below complies with the safety requirements of the Pressure Equipment Directive 2014/68/EU.

<b>Product:</b>	GEMÜ C60 CleanStar
<b>Versions:</b>	Actuator size 4
<b>Product name:</b>	Pneumatically operated diaphragm valve
<b>From production date:</b>	2022-05-15
<b>Notified body:</b>	TÜV Rheinland Industrie Service GmbH Am Grauen Stein 51105 Cologne, Germany
<b>Number:</b>	0035
<b>Certificate no.:</b>	01 202 926/Q-02 0036
<b>Conformity assessment procedure:</b>	Module H1
<b>Technical standard used in parts:</b>	AD 2000

**Note for products with a nominal size ≤ DN 25:**

The products are developed and produced according to GEMÜ process instructions and quality standards which comply with the requirements of ISO 9001 and ISO 14001.  
In accordance with Article 4, Paragraph 3 of the Pressure Equipment Directive 2014/68/EU, these products must not be identified by a CE label.

The sole responsibility for issuing this declaration of conformity lies with the company GEMÜ Gebr. Müller Apparatebau GmbH & Co. KG.

M. Barghoorn  
Head of Global Technics

Ingelfingen, 2022-05-09



GEMÜ Gebr. Müller Apparatebau GmbH & Co. KG  
Fritz-Müller-Straße 6-8, 74653 Ingelfingen-Criesbach, Germany  
Phone +49 (0) 7940 1230 · info@gemue.de  
www.gemu-group.com

Subject to alteration

07.2022 | 88819402