

## CleanStar® 3/5 Way PFA Diaphragm Valves

### Construction

The GEMÜ *CleanStar*® C60 / C67 HPW ultra pure pneumatically or manually operated 3/5 way diaphragm valves have a full PFA-HP body with two valve seats. All medium wetted parts are in PFA-HP or PTFE (diaphragm). The non-wetted bonnet is PVDF.

The standard version of type C60 (pneumatic) is designed as a diverter valve: 1 x NC and 1 x NO (2 pneumatic actuators C60, one normally closed, one normally open). C60 has a stroke limiter and an optical position indicator (1), C67 (manual) has a travel stop (6) as standard. Solid mounting lugs (2) are integrated and there is also a connection for a leakage detection sensor (3). The union nuts can be either in PVDF-HP, PFA-HP or C-PFA-HP (4). C67 has a standard optical position indicator (5).

### Advantages

- Minimal deadleg
- High Kv values
- Optional flow direction
- Can be used as a media blending valve
- Actuators can be independently controlled
- Can be fully integrated with existing GEMÜ process controls



GEMÜ *CleanStar*® 3 way valve C60 (pneumatic/pneumatic)



GEMÜ *CleanStar*® 3 way valve C60 (pneumatic/manual)

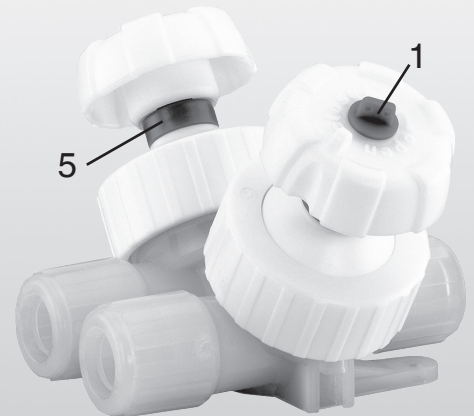

GEMÜ *CleanStar*® 3 way valve C67 (manual/manual)

### Dimensions GEMÜ C60 3 way valve (pneumatic/pneumatic) [mm/inch]

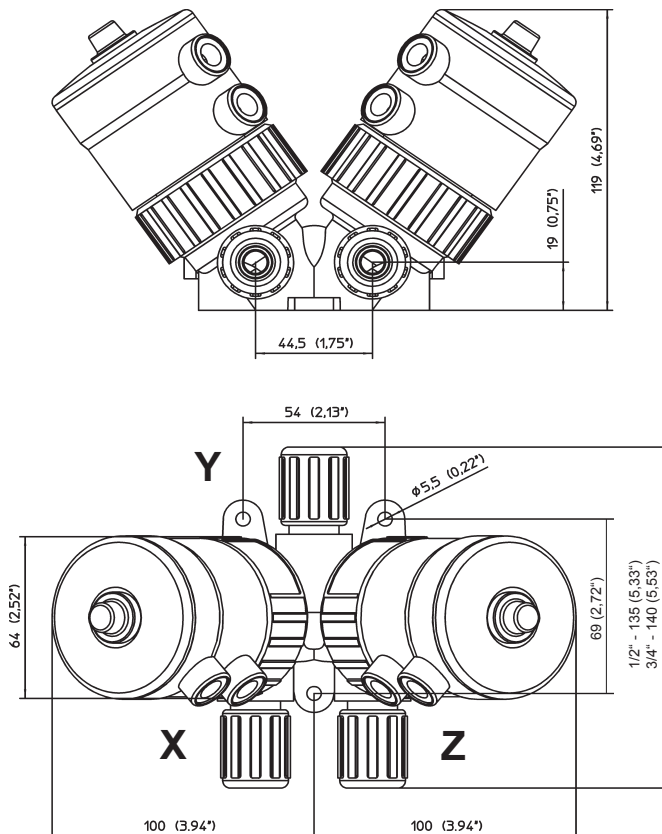

Range Overview **CleanStar®** C60/C67 3 way valves

Type of connection / Availability					Size		
Flare connection	Butt-weld spigots	Space saver			Connection		Actuator size
		Pos. X + Z	Pos. Y	Pos. X + Z + Y	Code international	DN	
					8 12	10 15	Code
1/2" - 1/2" - 1/2" 3/4" - 3/4" - 3/4"	on request	on request	on request	on request			

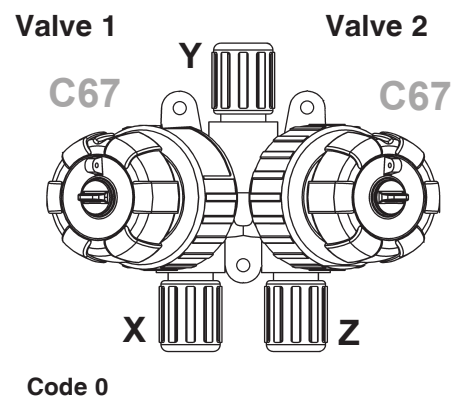
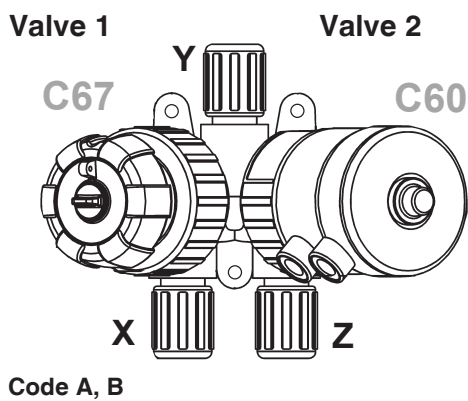
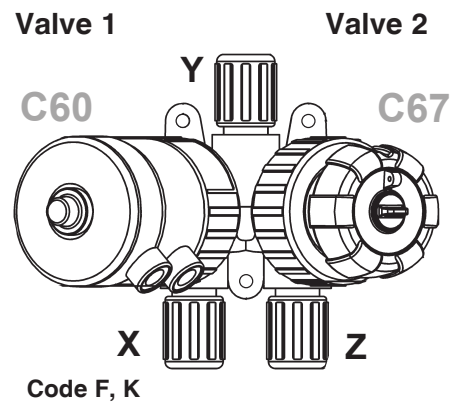
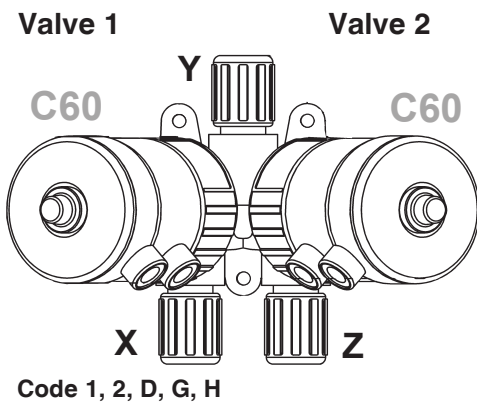

Control function				
Valve 1 (X - Y)		Valve 2 (Z - Y)		Code
Type	Control function	Type	Control function	
C60	Normally closed	C60	Normally closed	1
C60	Normally closed	C60	Normally open	D
C60	Normally closed	C67	Manually operated	F
C60	Normally open	C60	Normally open	2
C60	Normally open	C60	Normally closed	G
C60	Normally open	C67	Manually operated	K
C60	Normally open	C60	Double acting	H
C67	Manually operated	C60	Normally closed	A
C67	Manually operated	C60	Normally open	B
C67	Manually operated	C67	Manually operated	0

## Technical Data

### Flow medium

Suitable for any inert or corrosive gases or liquids, -especially high purity media- which do **not** corrode the respective body and diaphragm materials.

### Flow direction

Optional

### Operating pressure

Max. 6 bar when applied upstream only

Vacuum 400 mbar/abs\*

\* The life expectancy of the valve may be affected if exposed to a greater vacuum.

### Operating temperature

See temperature/pressure diagram on page 4

### Ambient temperature

Max. 60°C (130°F)

### Materials

Medium wetted parts (body)	PFA
Diaphragm	PTFE
Bonnet parts, non-wetted	PVDF

### Control pressure (only C60)

“Normally closed” (c.f. 1)	4-7 bar
“Normally open” (c.f. 2) and “double acting” (c.f. 3)	max. 4 bar

### Control air connection (only C60)

Size G 1/8



### Kv / Cv values

Connection			Size			Kv	Cv
Size	Connection	Code	Code international	DN	Actuator	l/min	US gal/min
1/2" tube	Flare connection	75 and 77	8	10	2	28	2.0
3/4" tube	Flare connection	75 and 77	12	15	2	53	3.7

### Control Air Volume - C60

Actuator size	Control function		Actuator Volume [cm <sup>3</sup> ]
2	1	Normally closed	24.0
	2	Normally open	39.0
	3	Double acting (closed)	39.0
	3	Double acting (open)	24.0

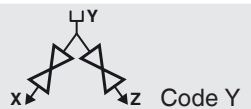
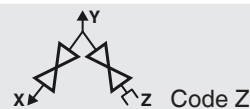
### Position space saver (optional)

Space saver X-position	Space saver Y-position	Space saver Z-position	Space saver X+Z-position
			

## Order data

1 Type	Code
C60 - Valve 1 (X - Y)	C60
C67 - Valve 1 (X - Y)	C67

2 Position of space saver (optional)	Code
Space saver in X-position	X
Space saver in Y-position	Y
Space saver in Z-position	Z
Space saver in X+Z-position	S

3 Nominal size (Connection Y)	Code
1/2" tube DN 10	8
3/4" tube DN 15	12

4 Body geometry	Code
V body	V

5 Connection type (Connection Y)	Code
Flare connection with C-PVA union nut (also for space saver)	73
Flare connection with PVDF union nut (also for space saver)	75
Flare connection with PFA union nut (also for space saver)	77

6 Body material	Code
PFA	30

7 Diaphragm material	Code
PTFE / EPDM, one-piece	54
PTFE/EPDM	5A

8 Control function	Code
C60 / C60 (Normally closed/Normally closed)	1
C60 / C60 (Normally closed/Normally open)	D
C60 / C67 (Normally closed/Manually operated)	F
C60 / C60 (Normally open/Normally open)	2
C60 / C60 (Normally open/Normally closed)	G
C60 / C67 (Normally open/Manually operated)	K
C60 / C60 (Normally open/Double acting)	H
C67 / C60 (Manually operated/Normally closed)	A
C67 / C60 (Manually operated/Normally open)	B
C67 / C67 (Manually operated/Manually operated)	0

9 Bonnet version	Code
Bonnet size 2	2
Bonnet size 2 with ECTFE union nut	2E

10 Position Space saver (optional)	Code
Space saver X-position	X
Space saver Y-position	Y
Space saver Z-position	Z
Space saver X+Z-position	S

11 Nominal size (connections X + Z)	Code
1/2" tube DN 10	8
3/4" tube DN 15	12

12 Connection type (connections X+ Z)	Code
Flare connection with C-PVA union nut (also for space saver)	73
Flare connection with PVDF union nut (also for space saver)	75
Flare connection with PFA union nut (also for space saver)	77

13 Body geometry	Code
High Purity, white	V

Order example	1	2	3	4	5	6	7	8	9	10	11	12	13
	C60	Y	8	V	75	30	5A	F	2	S	8	75	HPW

\* Connections are limited to versions with same nominal sizes at all positions. Size variations to follow.

## Temperature / pressure - diagram

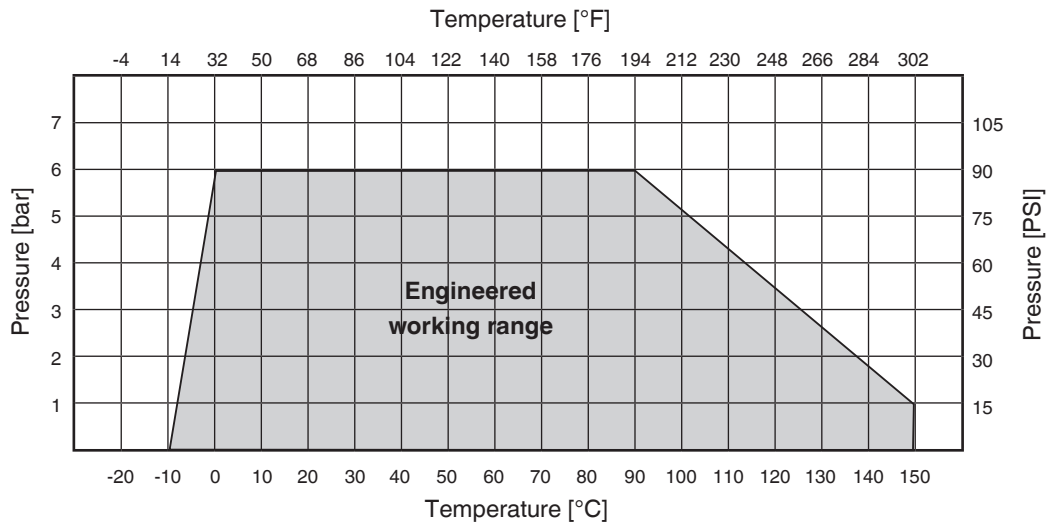

### Information on the use of the temperature / pressure diagram

The temperature / pressure diagram is only an orientation aid. The data refer to water as a working medium. A change of operating conditions or other media may result in deviations. In case of doubt it is advisable to test the behavior of the material under the definitive operating conditions by means of a test installation.

Temperatures below 0 °C can affect the operating speed negatively.

## Dimensions / Tolerances

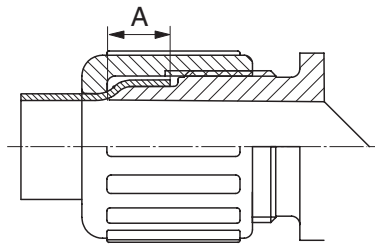

### Overlap dimensions and thread sizes of flare connections

Tube size	Thread designation	Standard	A mm [inch]
1/2"	3/4"-20-UNEF	ANSI B 1.1	12.0 [0.47"]
3/4"	1"-20-UNEF	ANSI B 1.1	14.0 [0.55"]

### Tolerances

- The **CleanStar**<sup>®</sup> plastic parts are manufactured to DIN 16901-140.
- In Space Saver - Flare connections tolerances of ±2.5mm are possible.
- Tolerance data for butt weld connections will vary depending on the design of the welding machine used.

Dimensions - GEMÜ C60 3 way valves (pneumatic/manual) [mm/inch]

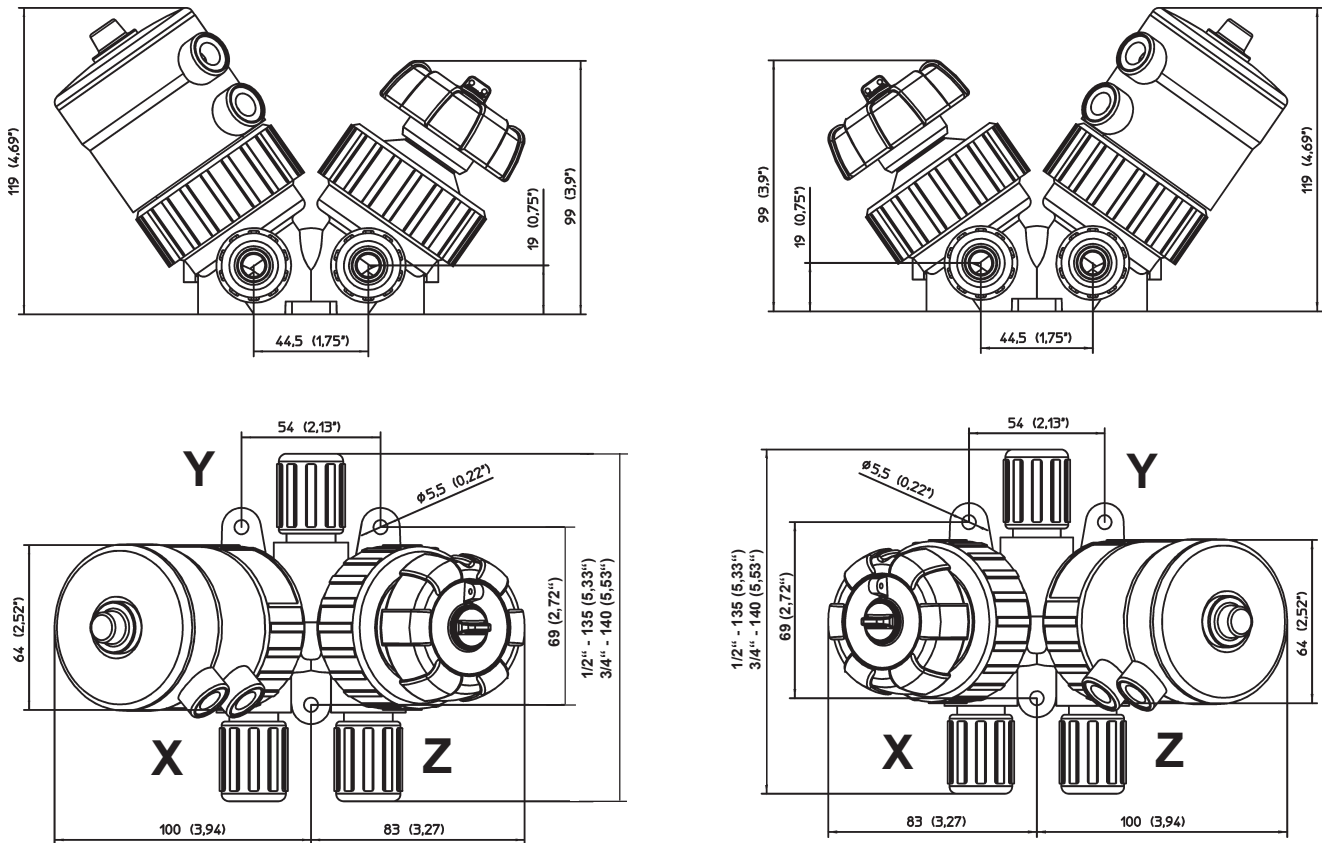

Dimensions - GEMÜ C67 3 way valves (manual/manual) [mm/inch]

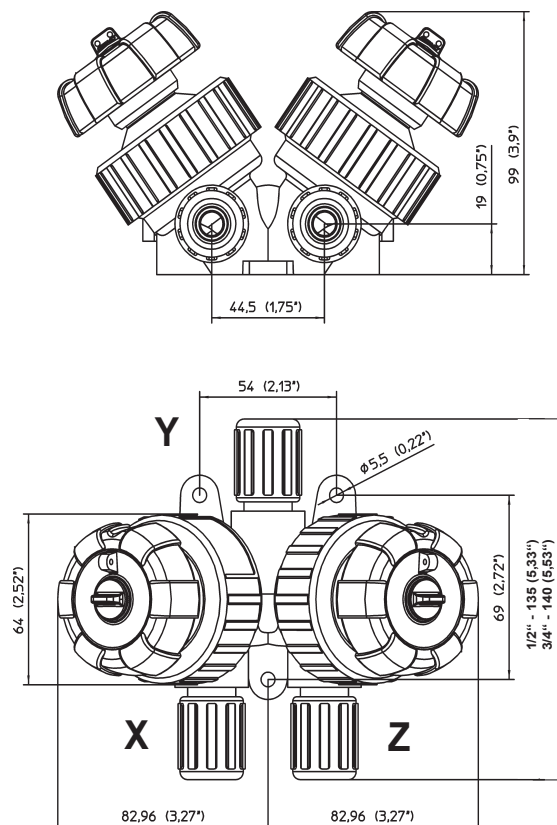

## Accessories



**GEMÜ C67 STA**  
Service tool for actuators



**GEMÜ 1098**  
Flaring mandrel



**GEMÜ CF STF**  
Service tool for  
flare union nuts



**GEMÜ C67 LOD**  
Lock out device