

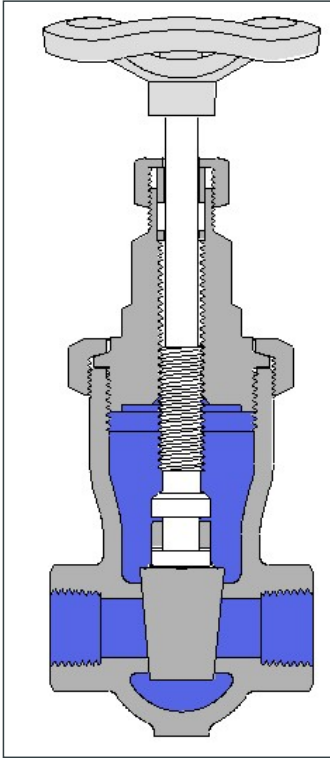

BLACKHALL

ALUMINIUM BRONZE GATE Series 4400

Data sheet No:13



Features

Blackhall - brooksbank aluminium bronze valves incorporate many unique features:

- Valves designed and engineered specifically for marine applications.
- Blow out proof spindle - one piece high strength design.
- Long life, low torque spindle thread.
- Lightweight ergonomic aluminium handwheel.
- Colour coded handwheel option - anodised blue, green, red or yellow.
- Precision lapped seat ensuring tight shut off
- Screwed bonnet and "difflock" design locking ring.
- Full Bore.

Technical Data

Valves are full bore, manual operated, inside screw, rising stem design.

Size Range	:DN 15 (1/2") to DN 50 (2")
Pressure Rating	:PN 40
Hydraulic Body Test Pressure	:60 Bar
Hydraulic Seat Test Pressure	:44 Bar
Temperature/Pressure Range	:30 Bar at 200°C





BLACKHALL

ALUMINIUM BRONZE GATE Series 4400

Data sheet No:13

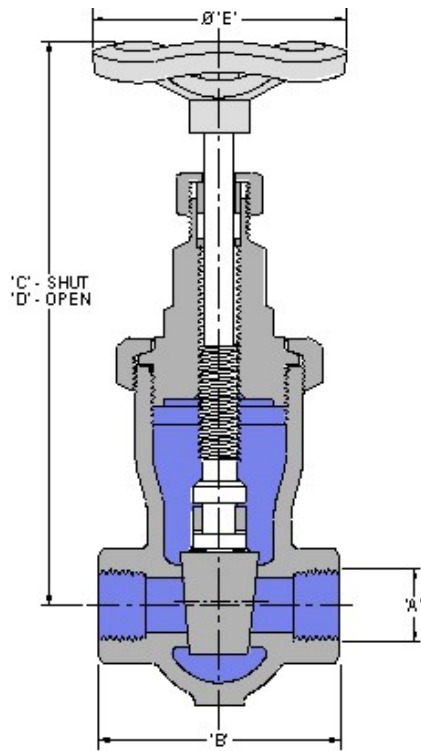

Component	Material
Body	Aluminum bronze
Wedge	Aluminum bronze/Monel
Bonnet locknut	Aluminum bronze
Bonnet	Aluminum bronze
Gasket	P.T.F.E./Graphite
Gland Washer	Aluminum bronze
Packing	P.T.F.E./Graphite
Gland nut	Aluminum bronze
Gland follower	Aluminum bronze
Handwheel	Aluminum alloy

Valve size	A	B	C	D	E	Cv	Weight
						US Units	kg
DN 15	½" NPT	70	164	189	80	22.5	1.5
DN 20	¾" NPT	70	164	189	80	41.5	1.6
DN 25	1" NPT	80	189	223	95	69.8	2.3
DN 32	1 ¼" NPT	96	220	260	110	113.3	4.0
DN 40	1 ½" NPT	96	220	260	110	181.1	4.1
DN 50	2" NPT	109	268	326	110	297.5	5

Technical Data

All valves are issued with Test Certification and Certificate of Conformity. DIN 50049 3.1.B Certification on request.

Ordering Information

Size	:DN 15 (1/2") to DN 50 (2")
Optional Extras	Handwheel Colour
	:PTFE or Graphite Packing
	:Monel Trim
	:PTFE Soft Seat
	:B.S.P.P. End Connection Available
	:B.S.P.P. End Connection Available

