

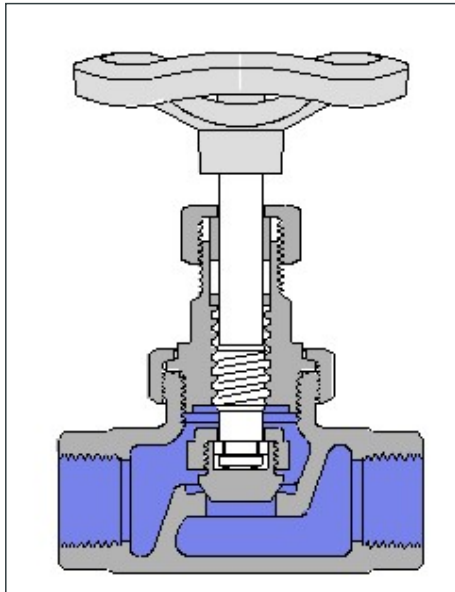

BLACKHALL

ALUMINIUM BRONZE GLOBE Series 4500

marine



Features

Blackhall aluminium bronze valves incorporate many unique features:

- Valves designed and engineered specifically for marine applications.
- Blow out proof spindle - one piece high strength design.
- Long life, low torque spindle thread.
- Lightweight ergonomic aluminium handwheel.
- Colour coded handwheel option - anodised blue, green, red or yellow.
- Precision lapped seat ensuring tight shut off.
- Long life adjustable one piece packing.
- Screwed bonnet and "difflock" design locking ring.
- Full Bore

Technical Data

Valves are full bore, manual operated, inside screw, rising stem design.

Size Range	:DN 10 (3/8") to DN 50 (2")
Pressure Rating	:PN 40
Hydraulic Body Test Pressure	:60 Bar
Hydraulic Seat Test Pressure	:44 Bar
Temperature/Pressure Range	30 Bar at 200°C
Fluids/Service	:40 Bar at -10° to 120° :Sea Water, Steam, Air, Gas, Light Liquids and Fuel Lines





BLACKHALL

marine



ALUMINIUM BRONZE GLOBE Series 4500

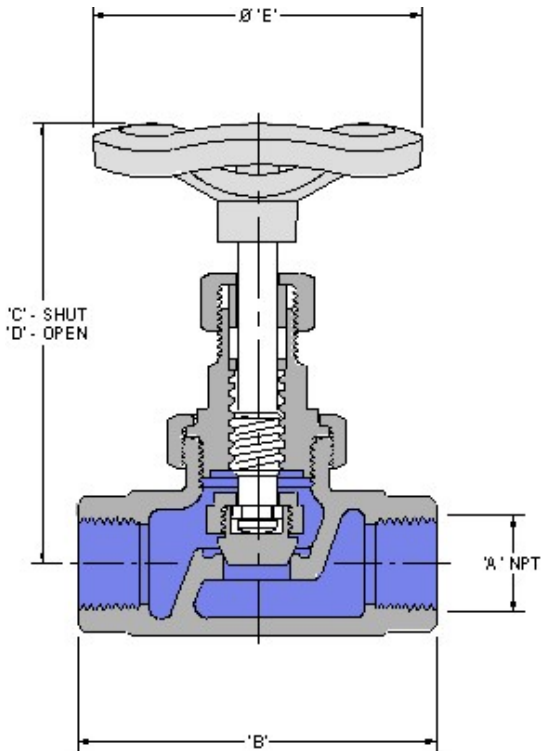

Component	Material
Body	Aluminum bronze
Stopper	Aluminum bronze/Monel
Split collar	Aluminum bronze
Stopper nut	Aluminum bronze
Gasket	P.T.F.E./Graphite
Bonnet locknut	Aluminum bronze
Bonnet	Aluminum bronze
Gland Washer	Aluminum bronze
Packing	P.T.F.E./Graphite
Gland nut	Aluminum bronze
Gland follower	Aluminum bronze
Stem	Aluminum bronze/Monel
Handwheel	Aluminum alloy

Valve Size	A	B	C	D	E	Cv	Weight
						US Units	kg
DN 10	3/8" NPT	80	99	104	80	3.5	0.55
DN 15	1/2" NPT	80	99	104	80	3.5	0.57
DN 20	3/4" NPT	90	125	131	95	10.4	1.20
DN 25	1" NPT	100	125	131	95	10.4	1.22
DN 32	1 1/4" NPT	110	150	162	110	27.8	2.60
DN 40	1 1/2" NPT	120	150	162	110	27.8	2.64
DN 50	2" NPT	130	175	189	110	45.6	3.30

Technical Data

All valves are issued with Test Certification and Certificate of Conformity. DIN 50049 3.1.B Certification on request.

Ordering Information

- Size :DN 10 (3/8") to DN 50 (2")
- Optional Extras :Regulating Stopper
- :Handwheel Colour
- :PTFE or Graphite Packing
- :Monel Trim

