

# PRODUCT SPECIFICATION SHEET

## EDI FlexAir<sup>®</sup> MiniPanel<sup>™</sup> Diffuser Fine Pore Flexible Membrane Technology

### High Oxygen Transfer Efficiency for Maximum Customer Value

- Highest horizontal projected diffuser area for maximum OTE performance
- Efficient geometry supports high density installations of over 65% floor coverage
- Precision die cut openings for high oxygen transfer, uniform air release, and low operating pressure
- Nano Pore<sup>™</sup> and Micro Pore<sup>™</sup> perforation options available for engineered OTE and operating pressure requirements
- Advanced technology premium quality membranes available in EPDM, urethane, or special polymer blends, plus BioShield<sup>™</sup> and BioCide<sup>™</sup> technologies for reduced fouling and maintenance
- Nominal 4.75 inch (121 mm diameter x 54 inch (1359 mm) length for a total active membrane area equal to 380 in<sup>2</sup> (0.245 m<sup>2</sup>)
- Integral triple check valve design prevents entry of liquid/solids into piping. Ideal for on / off applications
- Resistant to fouling and plugging for low maintenance
- ABS and PVC construction for maximum chemical, temperature, and UV resistance
- Spectrum<sup>™</sup> Saddle Mount provides maximum mechanical integrity, ease of installation and maintenance, and ability to relocate or add diffusers for process modifications
- Non-buoyant design for reduced stress on mounting connection
- Spectrum<sup>™</sup> Saddle Mount mounts on any pipe material (PVC, ABS, CPVC, SS, etc.)
- Available in 4 inch, 6 inch, 8 inch and 110 mm and 160 mm pipe sizes

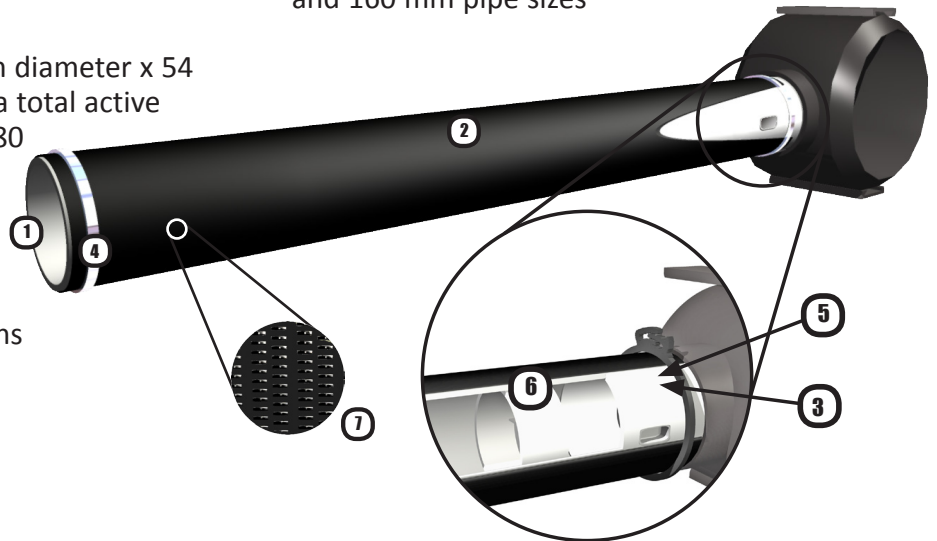

- |  |                              |
|--|------------------------------|
| 1. Membrane Support Tube                                 | 4. Membrane Clamp            |
| 2. Flexible Membrane Media                               | 5. Air Distribution Orifices |
| 3. Check Valve Feature with non-Perforated Membrane Area | 6. Internal End Plug         |
|  | 7. Die Cut Perforations      |



[www.wastewater.com](http://www.wastewater.com)  
Environmental Dynamics Incorporated

Value Solutions  
Since 1975

# PRODUCT SPECIFICATION SHEET

EDI FlexAir® MiniPanel™ diffuser is a unique fine pore, flexible membrane diffuser that provides superior operational flexibility and oxygen transfer efficiency compared to other membrane or rigid fine pore (ceramic) diffusers.

The MiniPanel diffuser features an exclusive top-half only perforation design. This design produces optimum oxygen transfer efficiency performance. A full 380 in<sup>2</sup> (0.245 m<sup>2</sup>) of perforated area is provided with a single MiniPanel diffuser (760 in<sup>2</sup> (0.490 m<sup>2</sup>) per diffuser assembly). The geometry of the diffuser supports high diffuser density applications over 65% floor coverage when the highest oxygen transfer efficiency is desired.

Unique to the FlexAir product is the ability to configure the diffuser for the objectives of the application. The MiniPanel diffuser may be configured with a micro pore, or nano pore membrane for optimized OTE and operating pressure performance. All FlexAir diffusers are configured with premium quality membranes that are engineered by the Membrane Technologies division at EDI. Alternate membrane materials and perforation patterns are available for non-standard industrial or municipal applications.

An integral triple check valve feature prevents the backflow of liquid into the diffuser and piping. The FlexAir MiniPanel diffuser is ideally suited for on/off applications and requires minimal maintenance for long-term performance.

The FlexAir MiniPanel diffuser is constructed of PVC or ABS for maximum chemical resistance and mechanical durability. ABS construction is recommended for high temperature applications or where cold temperature durability is required.

The FlexAir MiniPanel diffuser is exclusively available with the Spectrum Saddle Mount for maximum mechanical durability and ease of installation and maintenance. Unique to the Spectrum Saddle Mount is the ability to relocate or add diffusers to match process demands. This feature allows the aeration system to be reconfigured to match the specific oxygen demand or air handling requirements of the process. This is particularly beneficial in BNR applications where tight dissolved oxygen control is paramount. System expansions are also easily accommodated with this feature.

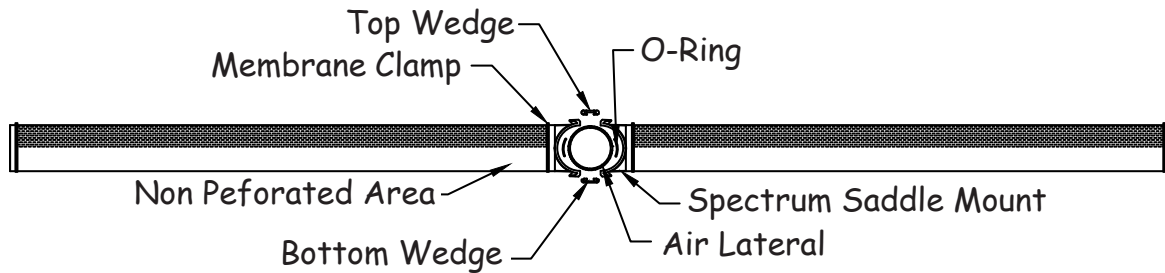

Diffuser Type	Design Airflow		Overall Length		Active Surface Area		Dry Weight		Net Operating Buoyancy	
	scfm	m <sup>3</sup> <sub>N</sub> /h	in	mm	ft <sup>2</sup>	m <sup>2</sup>	lb	kg	lb	kg
Nanopore	0-30	0-48	117.0	2970.0	5.28	0.491	22.0	9.8	6.5	3.0
Micropore	0-50	0-79	117.0	2970.0	5.28	0.491	22.0	9.8	6.5	3.0

- Optimum oxygen transfer efficiency is achieved when operating in the middle to low end of the airflow range. The approximate operating pressure of the diffuser at the mid-range is 13 to 16 inches (3.2-4.0 kPa).
- Operating the unit at the high end of the range will result in reduced performance and increased operating pressure. Use the maximum airflow value for short term operations such as peak loads or system maintenance.



**Environmental Dynamics Inc.**  
 5601 Paris Road • Columbia, MO 65202 USA  
 +1 877.EDI.AIR8 (334.2478) +1 573.474.9456

For Parts Information:  
[parts@wastewater.com](mailto:parts@wastewater.com)  
[www.diffuserexpress.com](http://www.diffuserexpress.com)

For System Information:  
[systems@wastewater.com](mailto:systems@wastewater.com)  
[www.wastewater.com](http://www.wastewater.com)