

**SQUARE PORT KNIFE GATE VALVE**

The **BC** model knife gate is a square port low-pressure valve for highly solid loaded fluids or solids, mainly used in bulk handling and silo outlet applications in industries such as:

- Chemical plants
- Power plants
- Food and Beverage
- Wastewater treatment Plants
- Mining
- etc.

**Sizes:** From 150 x 150 to 600 x 600 (other dimensions on request)

**Working pressure:** Fabricated valve  
150 x 150 to 600 x 600: 1 kg/cm<sup>2</sup>  
For higher pressure: Casted bodies (on request)

**Standard flange connection:** please refer to the table on page BC-8.  
Other flange connections available on request.

**Directives:** DIR 98/37/CE (MACHINES)  
DIR 97/23/CE (PED) Fluid: Group 1(b), 2 (Cat. I, mod. A)  
DIR 94/9/CE (ATEX) Group II, Cat. 3: zones 2 and 22

All valves are tested prior to shipping in accordance with the standard developed by the Quality Control Department at ORBINOX.

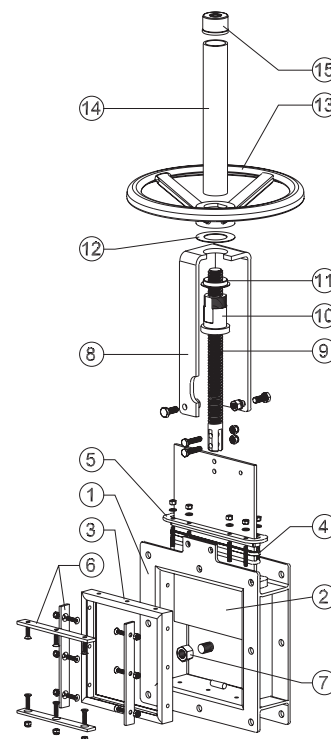

**STANDARD PARTS LIST**

**Part:**

1- Body	Carbon Steel	AISI 316
2- Gate	AISI 304	AISI 316
3- Seat	Metal or EPDM	
4- Packing	ST	
5- Gland Follower	Carbon Steel	AISI 316
6- Seal retainer plate	Carbon Steel	AISI 316
7- Slider support	Carbon Steel or AISI-316 + Nylon or PTFE	
8- Yoke	Carbon Steel - Epoxy coated	
9- Stem	AISI 303	
10- Stem nut	Brass	
11- Collar	Nylon	
12- Friction washer	Brass	
13- Handwheel	φ ≤ 310: Ductile Iron / φ ≥ 410: GJL 250 (GG25)	
14- Stem protector	Epoxy-coated Carbon Steel	
15- Cap	Plastic	



Reserves the right to change specifications without notice

**ORBINOX S.A.** Pol. Ind. s/n-20270 ANOETA (Spain) Tel.: +34 943 698030 - Fax: +34 943 653066 e-mail: orbinox@orbinox.com

**ORBINOX CANADA, ORBINOX USA, ORBINOX COMERCIAL, ORBINOX UK, ORBINOX FRANCE, ORBINOX GERMANY, ORBINOX INDIA, ORBINOX CHINA**

[www.orbinox.com](http://www.orbinox.com)

MODEL

BC

## DESIGN FEATURES

### **BODY:**

Fabricated design.

Internal gate wedges and guides for tighter shut off.

Square or rectangular port design for higher flow capacity and minimal pressure drop.

Internal design avoids any build up of solids that would prevent valve from closing.

### **GATE:**

Stainless steel gate as standard.

Gate is polished on both sides to avoid jamming and seat damage.

### **PACKING:**

Long-life packing with several layers of braided fibre plus an EPDM o-ring (resilient valves), with an easy access packing gland ensuring a tight seal. Long-life braided packing is available in a wide range of materials.

### **STEM:**

The standard stainless steel stem offers a long corrosion resistant life.

For rising stem handwheel actuators only, a stem protector is provided for additional protection against dust whilst the valve is in the open position.

### **ACTUATORS:**

All actuators supplied by **ORBINOX** are interchangeable, and supplied with an standard mounting kit to allow for installation on site.

### **YOKE or ACTUATOR SUPPORT:**

Made of EPOXY coated steel (stainless steel available on request).

Compact design makes it extremely robust even under the most severe conditions.

### **EPOXY COATING:**

The epoxy coating on all **ORBINOX** cast iron and carbon steel valve bodies and components is electrostatically applied making the valves to be corrosion resistant with a high quality finished surface.

The **ORBINOX** standard colour is RAL-5015 blue.

### **GATE SAFETY PROTECTION:**

**ORBINOX** automated valves are provided with gate guards in accordance with EU Safety Standards.

The design feature prevents any objects from being trapped accidentally while the gate is moving.



## OTHER OPTIONS

### FLUSH PORTS:

- Allow for cleaning of solids trapped within the body cavities that can obstruct the flow or prevent the valve from closing.
- Purging can be made with air, steam, liquids, etc. depending on the process.

### SPECIAL DESIGNS:

- **ORBINOX** is equipped for in house fabrication of special valves. Depending on the design, diameter, pressures, material of construction, etc.

### CASTED BODIES:

- Standard material: GG25 and CF8M. Special alloys such as 254SMO, Hastelloys,...

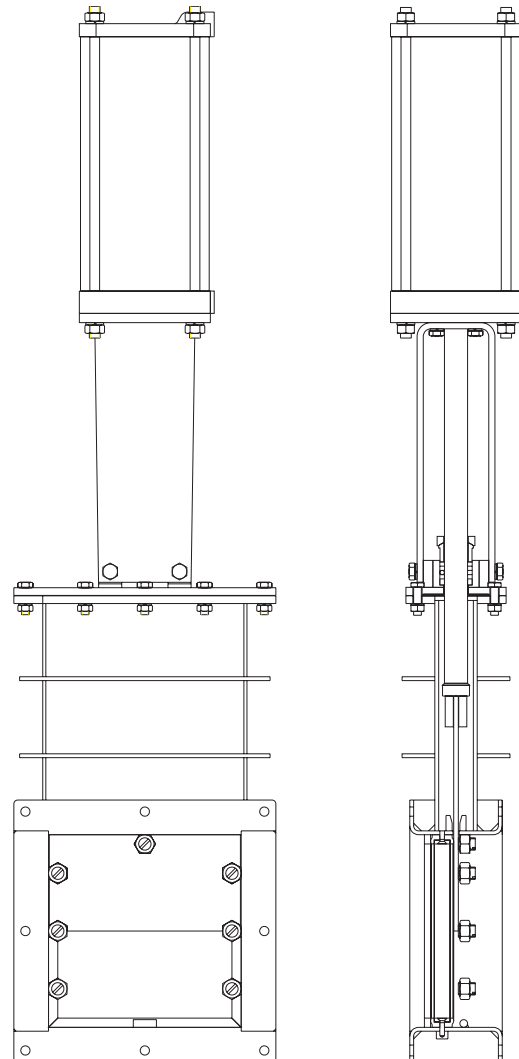
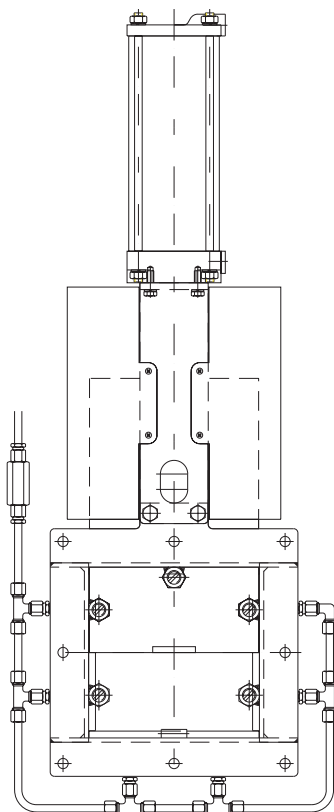

We recommend consultation with our technical department.

## ACTUATOR TYPES

### Manual:

Handwheel (rising & non-rising stem)  
 Chainwheel  
 Lever  
 Bevel Gear  
 Others (square nut...)

### Automatic:

Electric  
 Double Acting Pneumatic  
 Single Acting Pneumatic  
 Hydraulic

All actuators supplied by ORBINOX are interchangeable.

## FAIL SAFE SYSTEMS

Used on pneumatic actuated valves.

### SINGLE ACTING / VOLUME TANK

Available for all sizes.

Options:

- Pneumatic Failsafe
- Pneumatic or Electric failsafe

## ACCESSORIES

- Mechanical stops
- Locking device
- Manual override
- Solenoid valves
- Positioners
- Limit switches
- Proximity switches
- Floor stands
- Stem extensions

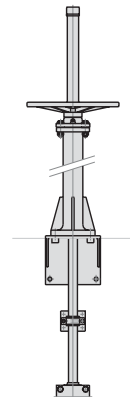

Wide range of valve extensions available.

*For further information about fail safe systems and valve extensions, please see EX chapter.*

We recommend consultation with our technical department.

**TEMPERATURE CHART**

SEAT / SEALS			PACKING		
Material	Max.Temp.(°C)	Applications	Material	Max. Temp. (°C)	pH
Metal/Metal	>250	High temp. Low tightness.	Dry cotton (AS)	50	6 - 8
EPDM (E)	120	Acids and non mineral oils.	PTFE impregn. synth. fibre (ST)	240	2 - 13
Nitrile (N)	120	Resistance to petroleum products.	Braided PTFE (TH)	260	0 - 14
Viton (V)	200	General chemical service.	Graphited (GR)	600	0 - 14
		High temperature.	Ceramic fibre (FC)	1200	—
Silicone (S)	250	Food service. / High temperature.	NOTE: all types include an elastomere O-ring (same material as seal), excluding TH, GR and FC.		
PTFE (T)	250	Corrosion resistance.			

More details and other materials under request.

**SEAT TYPES**

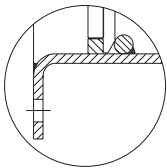

**METAL / METAL**

For applications with:

- High temperature
- High density media application
- When full tightness is not required

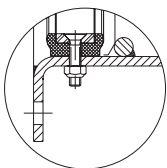

**RESILIENT**

- Temperature limitations according to seat material selected. Consult the above chart or our technical department for more information.
- Replaceable seal retainer plates.

## HANDWHEEL (rising stem)

- Standard handwheel actuator.
- Consists on:
  - Handwheel: Epoxy coated Cast Iron
  - Stem
  - Stem nut
  - Stem protector
- Available from 150 x150 to 600 x 600
- Options:
  - Locking Device
  - Extensions

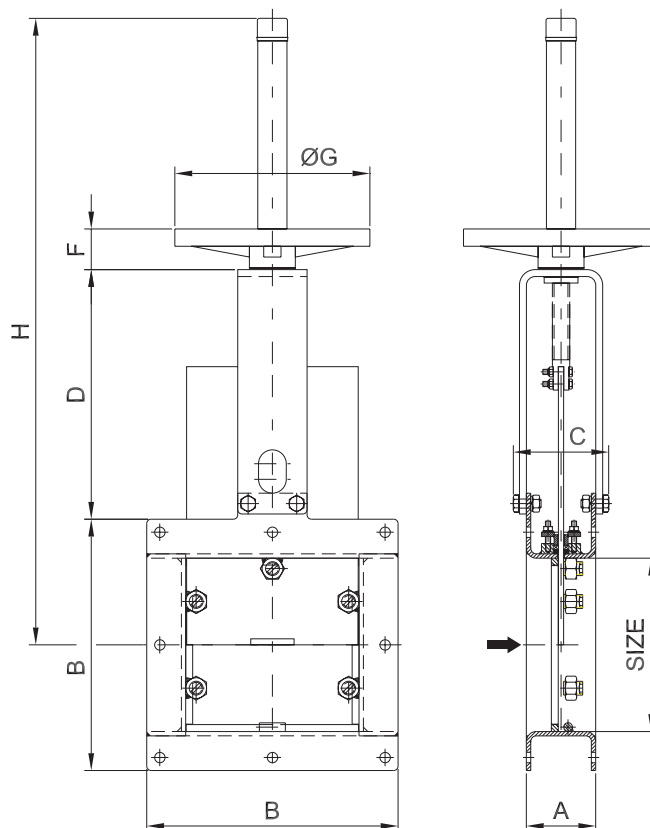

SIZE	A	B	C	D	ØG	F	H	Weight (kg.)
150 x 150	80	240	110	219	225	47	580	23
200 x 200	80	290	115	288	310	67	740	27
250 x 250	80	340	115	338	310	67	915	32
300 x 300	80	390	115	388	310	67	990	38
350 x 350	100	450	137	444	410	68	1165	58
400 x 400	100	500	137	494	410	68	1240	66
450 x 450	100	550	137	544	410	68	1390	75
500 x 500	100	600	137	594	410	68	1575	85
600 x 600	100	700	137	694	410	68	1725	110

**PNEUMATIC CYLINDER**

- The standard pneumatic actuator (double acting on-off cylinder) consists of:
  - Aluminium jacket and covers
  - Stainless steel (AISI 304) piston rod
  - Nitrile coated steel piston
- Available from 150 x 150 to 600 x 600
- Supply Pressure: minimum 3.5 kg/cm<sup>2</sup> - maximum 10 kg/cm<sup>2</sup>
- Options:
  - Hard anodized jacket and covers
  - Over / Undersized cylinder
  - Stainless Steel jacket and covers
  - Manual override
  - Fail safe systems
  - Travel stops
- Instrumentation (on request):
  - Positioners
  - Solenoid valves
  - Flow regulators
  - Air preparation units

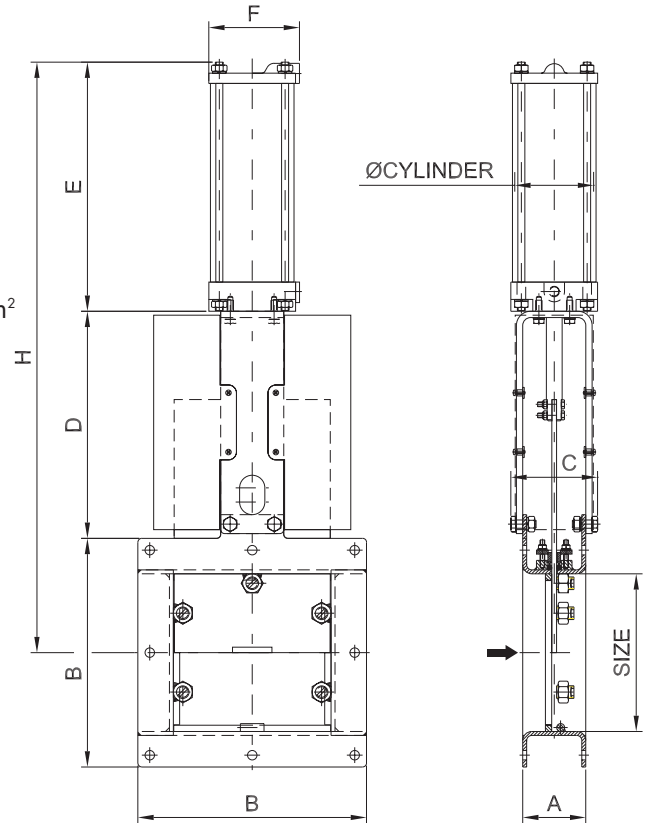

SIZE	A	B	C	D	E	F	H	Weight (kg.)	Standard Cyl. Connect.
150 x 150	80	240	110	219	266	115	605	25	C100/150 1/4" G
200 x 200	80	290	115	288	317	115	750	30	C100/200 1/4" G
250 x 250	80	340	115	338	367	115	875	35	C100/250 1/4" G
300 x 300	80	390	115	388	417	115	1000	42	C100/300 1/4" G
350 x 350	100	450	137	444	485	140	1154	63	C125/355 1/4" G
400 x 400	100	500	137	494	535	140	1279	72	C125/405 1/4" G
450 x 450	100	550	137	544	585	140	1404	80	C125/455 1/4" G
500 x 500	100	600	137	594	650	175	1544	98	C160/510 1/4" G
600 x 600	100	700	137	694	750	175	1794	125	C160/610 1/4" G

Note: For higher real working pressure (casted bodies), contact our technical department in order to oversize the actuator properly.

**FLANGE AND BOLTING DETAILS**

DN	A x A	n° divis. to Y = Z	d	⊕
150 x 150	240 x 240	2 div. to 105 = 210	12	8
200 x 200	290 x 290	2 div. to 130 = 260	12	8
250 x 250	340 x 340	2 div. to 155 = 310	12	8
300 x 300	390 x 390	3 div. to 120 = 360	12	12
350 x 350	450 x 450	3 div. to 140 = 420	14	12
400 x 400	500 x 500	4 div. to 117,5 = 470	14	16
450 x 450	550 x 550	4 div. to 130 = 520	14	16
500 x 500	600 x 600	4 div. to 142,5 = 570	14	16
600 x 600	700 x 700	4 div. to 167,5 = 670	14	16

150X150 a 250X250

300X300 a 350X350

400x400 a 600x600

