



Butterfly valve Type MTV and MTVF

Si-205 EN

Edition: 2008-08

Type MTV Type MTVF	Wafer design Flanged design
Nominal pressure	- PN 10 - 25
Nominal size	- DN 80 - 500
Material	- Stainless steel

The SOMAS butterfly valve type MTV

- **Advanced triple eccentric design**
- **is designed for control and shut-off applications.**
- **is designed for applications up to 350°C (662°F).**
- **has a tightness class in accordance with IEC 534-4 Class V as standard.**
- **has a solid seat made of stainless steel.**

Option

- **PTFE-seat**
- **High temperature applications up to 550°C (1022°F)**

SOMAS butterfly valves, type MTV and MTVF, are control, on/off and shut-off valves. These valves are designed to handle a wide range of liquids, gases and steam within a broad temperature range.

The MTV valve can be mounted between flanges and also supplied in lugged design.

The valve type MTVF is a full flanged butterfly valve.

The valves have an advanced triple eccentric design including a unique shape of the disc allows the use of a solid stainless steel seat.

The solid seat remains un-affected by high flow velocities and temperatures. A good valve function is achieved even on difficult applications.

The SOMAS valves are delivered ready for installation and operation. The valve assemblies are delivered factory tested as complete units with actuators, positioners and accessories.





Tightness class

The tightness class is related to the chosen material in the seat ring.

Metal seat (Code C alt. D) IEC 534-4 Class V
 PTFE-seat (Code A) IEC 534-4 Class VI (Option)

Pressure and temperature rating

Pressure
 Bar, gauge

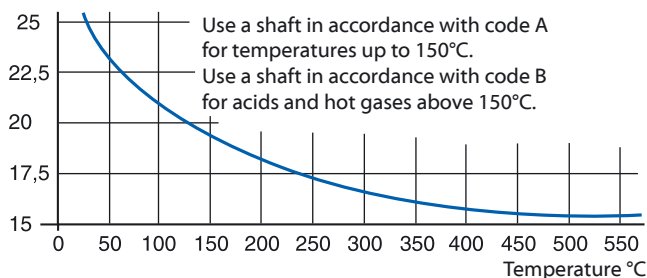

Flow characteristics

100% Flow

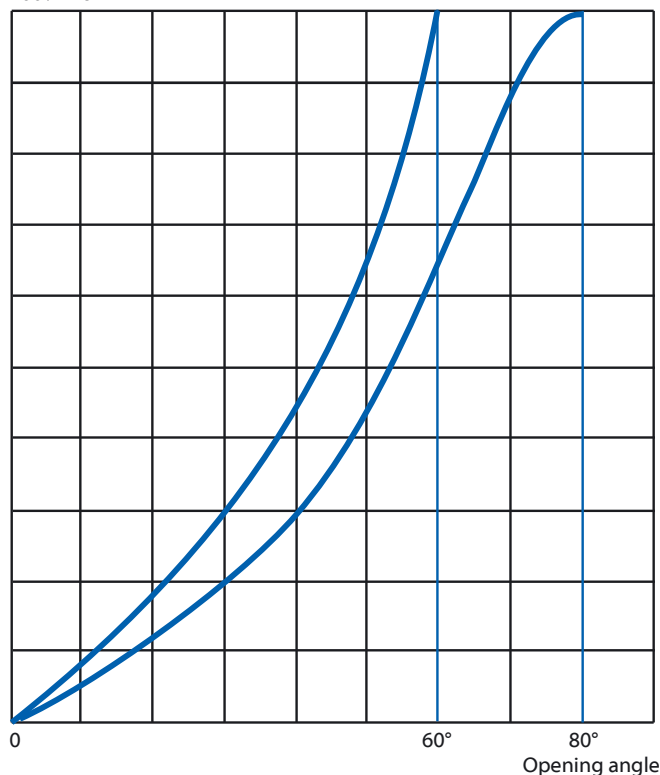

Factor F_{LP}

F _{LP}	Opening angle								
	10°	20°	30°	40°	50°	60°	70°	80°	90°
	0.88	0.86	0.81	0.78	0.71	0.63	0.53	0.50	0.52

Factor F_{LP} is valid for all sizes.

Liquid pressure recovery factor F_L

Factor F _L	Opening angle								
	10°	20°	30°	40°	50°	60°	70°	80°	90°
	0.88	0.86	0.82	0.80	0.74	0.68	0.61	0.60	0.59

Pipe geometry factor F_p

Valve DN	Pipe DN	Opening angle								
		10°	20°	30°	40°	50°	60°	70°	80°	90°
80	100				0.99	0.99	0.96	0.93	0.91	0.93
	150	1.0	1.0	0.99	0.98	0.97	0.92	0.86	0.83	0.86
	200				0.97	0.94	0.88	0.81	0.77	0.81
100	150				0.98	0.97	0.93	0.88	0.84	0.88
	200	1.0	1.0	0.99	0.97	0.94	0.87	0.80	0.76	0.80
	250				0.96	0.93	0.85	0.77	0.72	0.77
125	150				0.98	0.95	0.91	0.91	0.88	0.91
	200	1.0	1.0	0.99	0.95	0.89	0.83	0.83	0.79	0.83
	250				0.93	0.86	0.78	0.78	0.74	0.78
150	200				0.98	0.95	0.91	0.91	0.88	0.91
	250	1.0	1.0	0.99	0.95	0.89	0.83	0.83	0.79	0.83
	300				0.93	0.86	0.78	0.78	0.74	0.78
200	250				0.99	0.98	0.96	0.93	0.91	0.93
	300	1.0	1.0	0.99	0.98	0.96	0.92	0.86	0.83	0.86
	350				0.97	0.94	0.88	0.81	0.77	0.81
250	300				0.99	0.99	0.97	0.95	0.93	0.95
	350	1.0	1.0	0.99	0.99	0.97	0.93	0.88	0.85	0.88
	400				0.98	0.95	0.90	0.83	0.80	0.83
300	350				0.99	0.99	0.98	0.96	0.95	0.96
	400	1.0	1.0	0.99	0.99	0.98	0.94	0.90	0.87	0.90
	500				0.98	0.96	0.91	0.85	0.82	0.85
350	400				0.99	0.99	0.97	0.95	0.93	0.95
	500	1.0	1.0	0.99	0.99	0.98	0.94	0.90	0.87	0.90
	600				0.98	0.96	0.91	0.85	0.82	0.85
400	500				0.99	0.99	0.99	0.97	0.97	0.97
	600	1.0	1.0	0.99	0.99	0.98	0.96	0.93	0.91	0.93
	700				0.98	0.96	0.91	0.85	0.82	0.85
500	600				0.99	0.99	0.99	0.98	0.98	0.98
	700	1.0	1.0	0.99	0.98	0.97	0.93	0.88	0.85	0.88
	800				0.98	0.95	0.89	0.83	0.79	0.83

Capacity factor K_v and Resistance factor \square for butterfly valve type MTV/MTVF

DN	Opening angle									
	10°	20°	30°	40°	50°	60°	70°	80°	90°	\square 90°
80	14	31	48	73	108	165	203	235	205	1.18
100	21	45	70	107	158	240	324	375	326	1.13
125	35	75	116	177	262	400	520	605	523	1.06
150	50	108	168	256	379	580	780	905	784	0.98
200	89	193	299	457	675	1030	1390	1610	1397	0.99
250	142	307	476	727	1076	1650	2211	2555	2222	0.95
300	207	446	692	1058	1566	2400	3219	3720	3235	0.93
350	279	602	934	1427	2111	3230	4341	5020	4362	0.95
400	371	800	1242	1898	2809	4300	5775	6675	5805	0.91
500	584	1258	1951	2981	4413	6760	9071	10485	9117	0.90

Relation between K_v and C_v: K_v = 0.86 C_v

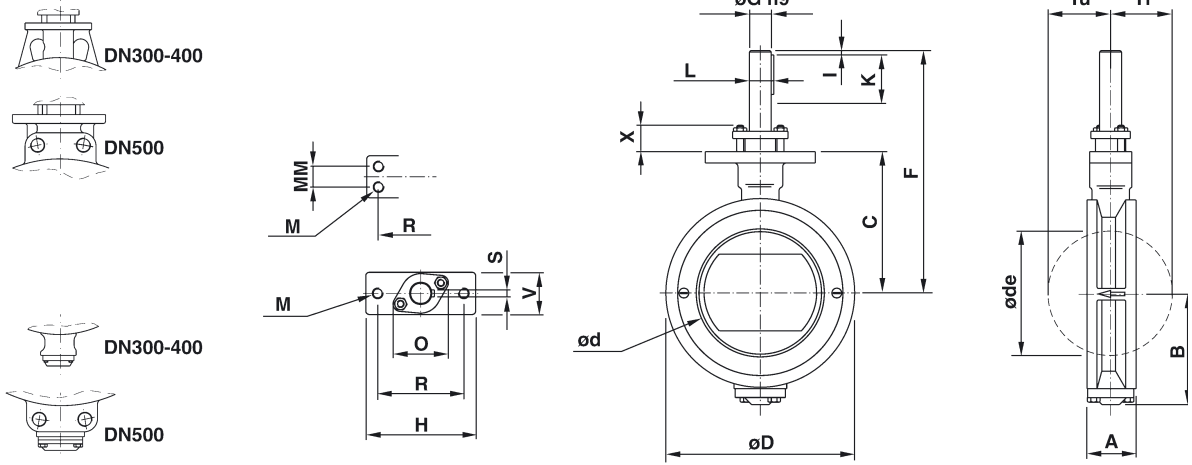

A = Mounting dimension according to EN 558-1 series 20 and EN 558-2 series 20

Butterfly valve type MTV																						
DN	A	B	C	ød	øde	øD	F	øG	H	I	K	L	M	MM	O	R	S	V	X	Tu	Ti	Weight
80	46	86	111	70	60	133	226	20	125	5	45	22.5	M12	—	61	98	6	40	30	41	38	5
100	52	99	128	90	86	160	243	20	125	5	45	22.5	M12	—	61	98	6	44	30	52	48	6
125	56	113	146	116	110	188	261	20	125	5	45	22.5	M12	—	61	98	6	48	30	64	60	9
150	56	127	161	140	138	215	276	25	125	5	45	28	M12	—	66	98	8	48	30	77	73	11
200	60	153	191	187	186	270	306	25	125	5	45	28	M12	—	66	98	8	48	30	100	96	17
250	68	188	225	236	235	324	360	30	150	5	60	33	M12	24	72	123	8	50	40	124	120	26
300	78	261	265	285	285	374	400	35	150	3	50	38	M12	24	75	123	10	60	40	149	145	39
350	78	287	294	331	330	432	449	40	150	3	50	43	M12	40	95	123	12	70	50	172	167	59
400	102	339	330	382	380	485	530	50	170	3	80	53.5	M16	55	105	136	14	87	50	199	194	82
500	127	396	395	479	475	590	605	60	210	3	90	64	M20	70	116	150	18	120	60	249	242	149

øde = Necessary free diameter for the disc under movement

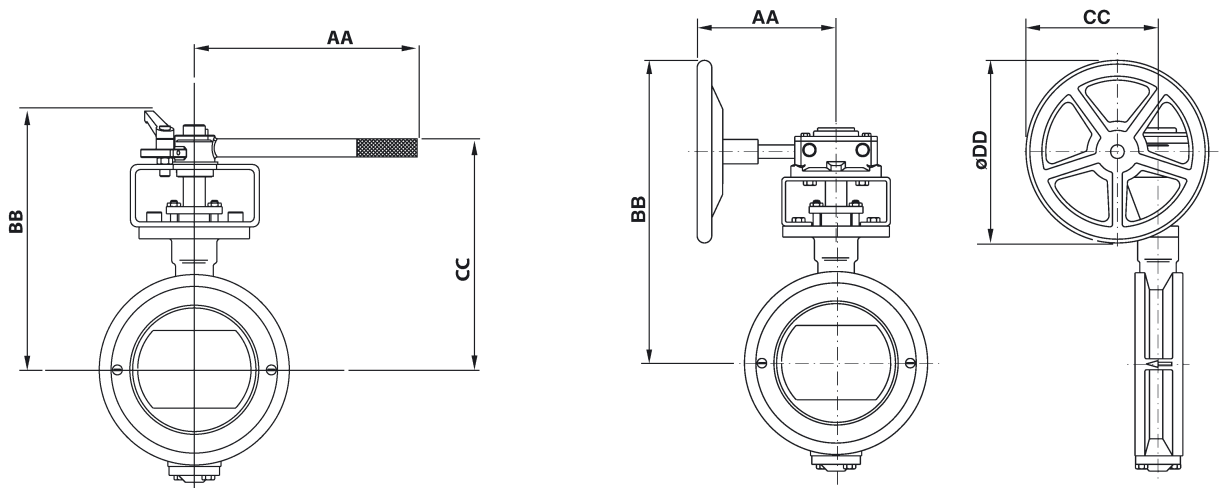

Butterfly valve type MTV with hand lever					
DN	Type	AA	BB	CC	Weight
80	HSR20	355	236	206	8
100	HSR20	355	251	223	9
125	HSR20	355	271	241	12

Butterfly valve type MTV with gear unit						
DN	Type	AA	BB	CC	øDD	Weight
80	M10/F07	185	350	180	250	13
100	M10/F07	185	365	180	250	14
125	M10/F07	185	330	180	250	17
150	M10/F07	185	395	180	250	19
200	M10/F07	185	425	180	250	25
250	M12/F12	225	500	220	300	38
300	M12/F12	225	540	220	300	51
350	M12/F12	225	605	220	300	71
400	M14/F14	250	665	265	350	103
500	M15/F16	365	870	430	610	187

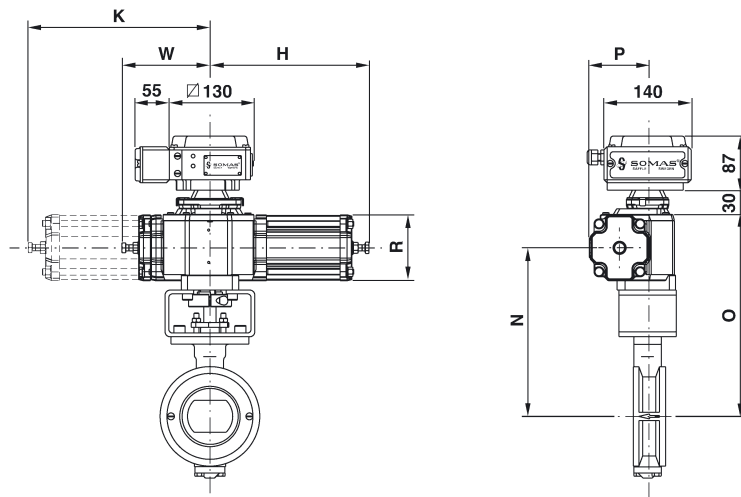

Butterfly valve, type MTV with actuator type A-DA										Actuator type A-SC/SO									
DN	Type	H	K	N	O	P	R	W	Weight	DN	Type	H	K	N	O	P	R	W	Weight
80	A13	250	—	235	285	83	106	90	11	80	A23-X	415	—	255	320	117	152	140	22
80	A21	255	—	255	320	94	106	140	14	100	A24-X	415	420	270	335	117	152	—	33
100	A21	255	—	270	335	94	106	140	15	125	A24-X	415	420	290	355	117	152	—	36
100	A22	255	260	270	335	94	106	—	17	150	A24-X	415	420	305	370	117	152	—	38
125	A22	255	260	290	355	94	106	—	20	200	A24-X	415	420	335	400	117	152	—	44
150	A22	255	260	305	370	94	106	—	22	250	A33-X	660	—	420	510	185	230	215	84
200	A22	255	260	335	400	94	106	—	28	300	A33-X	660	—	460	550	185	230	215	97
250	A23	305	—	380	445	117	152	140	42	350	A34-X	665	680	505	590	185	230	—	145
250	A31	380	—	420	510	144	152	215	51	400	A43-X	920	—	605	730	280	355	315	245
300	A31	380	—	460	550	144	152	215	64	500	A44-X	925	935	670	795	280	355	—	365
300	A32	380	395	460	550	144	152	—	70										
350	A32	380	395	505	590	144	152	—	90										
400	A32	380	395	560	645	144	152	—	113										
400	A33	470	—	560	645	185	230	215	120										
500	A41	550	—	670	795	210	230	315	226										
500	A42	545	560	670	795	210	230	—	241										

For units with the positioner type SP405, add 2 kg.
 For units with the positioner type SPE405, add 3 kg.

X = SC – Spring closes
 X = SO – Spring opens

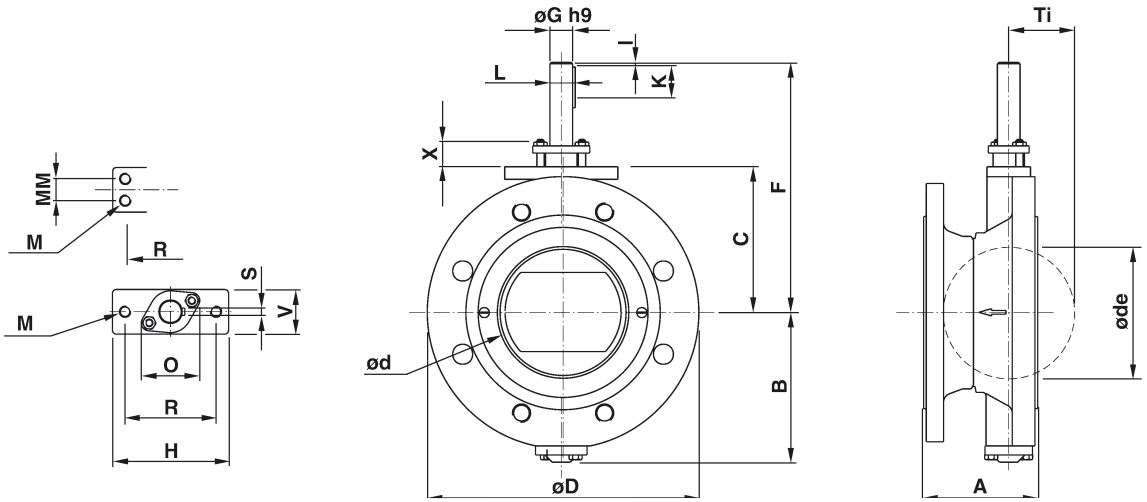

A = Mounting dimension according to EN 558-1 series 13 and EN 558-2 series 13

Butterfly valve type MTFV																					
DN	A	B	C	ød	øde	øD	F	øG	H	I	K	L	M	MM	O	R	S	V	X	Tu	Weight ¹
80	114	110	111	70	60	According to the flange standard	226	20	125	5	45	22.5	M12	—	61	98	6	40	30	38	12
100	127	130	128	90	86		243	20	125	5	45	22.5	M12	—	61	98	6	44	30	48	15
125	140	150	146	116	110		261	20	125	5	45	22.5	M12	—	61	98	6	48	30	60	22
150	140	160	161	140	138		276	25	125	5	45	28	M12	—	66	98	8	48	30	73	27
200	152	190	191	187	186		306	25	125	5	45	28	M12	—	66	98	8	48	30	96	42
250	165	220	225	236	235		360	30	150	5	60	33	M12	24	72	123	8	50	40	120	64
300	178	255	265	285	285		400	35	150	3	50	38	M12	24	75	123	10	60	40	145	87
350	190	285	294	331	330		449	40	150	3	50	43	M12	40	95	123	12	70	50	167	145
400	216	320	330	382	380		530	50	170	3	80	53.5	M16	55	105	136	14	87	50	194	200
500	229	375	395	479	475		605	60	210	3	90	64	M20	70	116	150	18	120	60	242	365

øde = Necessary free diameter for the disc under movement

¹ Approximate value dependent on PN-class

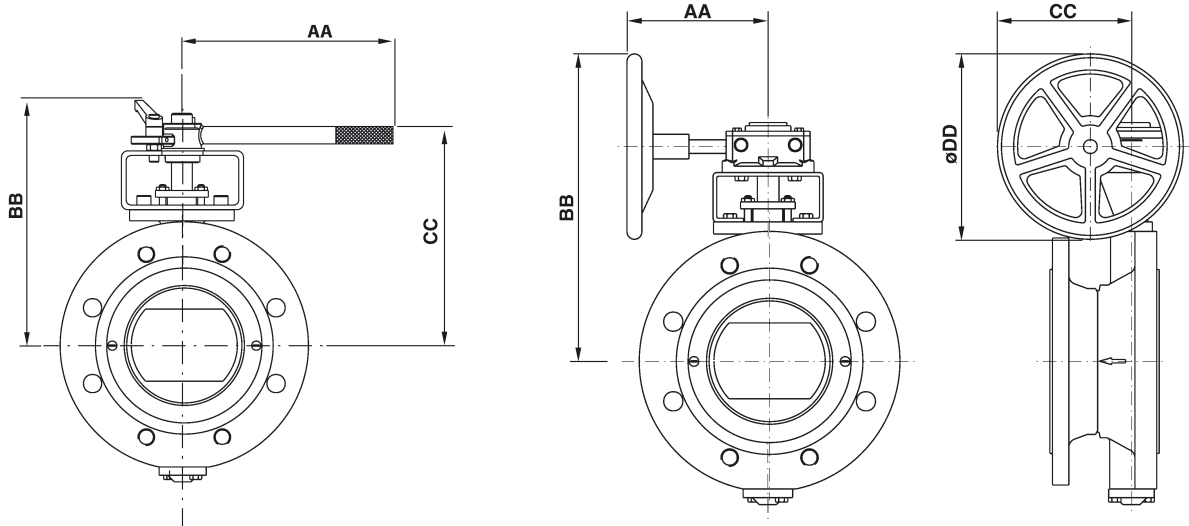

Butterfly valve, type MTFV with hand lever					
DN	Type	AA	BB	CC	Weight ¹
80	HSR20	355	236	206	15
100	HSR20	355	251	223	18
125	HSR20	355	271	241	25

¹ Approximate value dependent on PN-class

Butterfly valve, type MTFV with gear unit						
DN	Type	AA	BB	CC	øDD	Weight ¹
80	M10/F07	190	360	190	255	20
100	M10/F07	190	375	190	255	23
125	M10/F07	190	395	190	255	30
150	M10/F07	190	410	190	255	35
200	M10/F07	190	440	190	255	50
250	M12/F12	228	545	230	305	76
300	M12/F12	228	585	230	305	99
350	M12/F12	228	615	270	305	157
400	M14/F14	250	680	270	355	221
500	M15/F16	335	800	353	460	403

¹ Approximate value dependent on PN-class

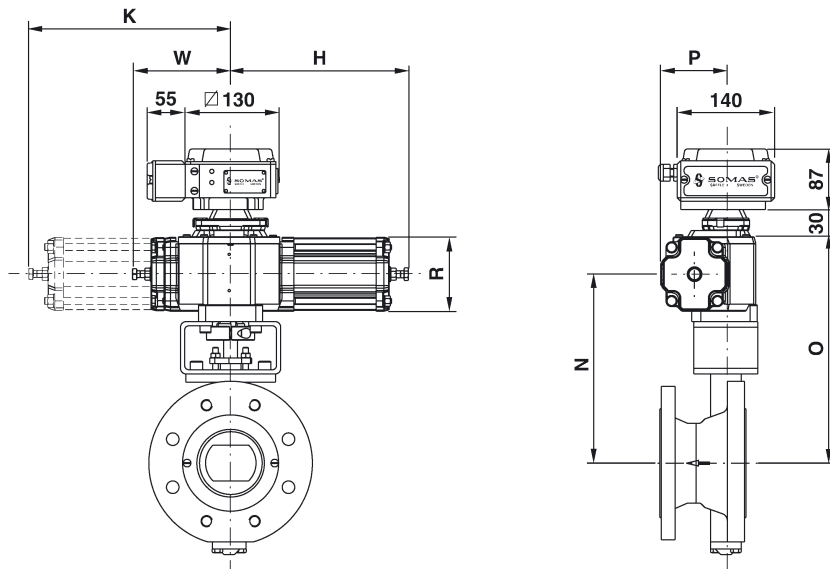

Butterfly valve, type MTFV with actuator type A-DA										Actuator type A-SC/SO									
DN	Type	H	K	N	O	P	R	W	Weight ¹	DN	Type	H	K	N	O	P	R	W	Weight ¹
80	A13	250	—	235	285	83	106	90	18	80	A23-X	415	—	255	320	117	152	140	29
80	A21	255	—	255	320	94	106	140	22	100	A24-X	415	420	270	335	117	152	—	42
100	A21	255	—	270	335	94	106	140	25	125	A24-X	415	420	290	355	117	152	—	49
100	A22	255	260	270	335	94	106	—	26	150	A24-X	415	420	305	370	117	152	—	54
125	A22	255	260	290	355	94	106	—	33	200	A24-X	415	420	335	400	117	152	—	69
150	A22	255	260	305	370	94	106	—	38	250	A33-X	660	—	420	510	185	230	215	122
200	A22	155	260	335	400	94	106	—	53	300	A33-X	660	—	460	550	185	230	215	145
250	A23	305	—	380	445	117	152	140	81	350	A34-X	665	680	505	590	185	230	—	230
250	A31	380	—	420	510	144	152	215	89	400	A43-X	920	—	605	730	280	355	315	365
300	A31	380	—	460	550	144	152	215	112	500	A44-X	925	935	670	795	280	355	—	585
300	A32	380	395	460	550	144	152	—	118										
350	A32	380	395	505	590	144	152	—	175										
400	A32	380	395	560	645	144	152	—	230										
400	A33	470	—	560	645	185	230	215	240										
500	A41	550	—	670	795	210	230	315	445										
500	A42	545	560	670	795	210	230	—	460										

For units with the positioner type SP405, add 2 kg.
 For units with the positioner type SPE405, add 3 kg.

X = SC - Spring closes
 X = SO - Spring opens

¹ Approximate value
 dependent on PN-class

Supplemental information

Gaskets

Note: Use gaskets with the correct inside diameter to ensure that pressure is applied on the cover plate.

For mounting between flanges according to PN 10-25, the inside gasket diameter should not exceed the dimensions specified in the standard DIN-EN 1514-1. See the table below.

Valve DN	Ins. dia. di (mm)	Out. dia. (dy) (mm)		
		PN 10	PN 16	PN 25
80	89	142	142	142
100	115	162	162	168
125	141	192	192	194
150	169	218	218	224
200	220	273	273	284
250	273	328	329	340
300	324	378	384	400
350	356	438	444	457
400	407	489	495	514
500	508	594	617	624

For mounting between flanges according to ANSI 150 dimensions according to the standard ANSI B 16.21 RF are valid where the following dimensions refer to the gasket:

Valve DN	Ins. dia. di (mm)	Out. dia. (dy) (mm) ANSI 150
80	89	136
100	114	174
125	141	196
150	168	222
200	219	279
250	273	340
300	324	410
350	356	451
400	406	515
500	508	606



Flange standard

SOMAS butterfly valve type MTV in this data sheet is of wafer type for mounting between flanges PN 10-25.

The valve can also be delivered with "lugs"

The butterfly valve type MTVF is equipped with flanges which can be drilled for PN 10-25.

Both types of valve can also be drilled for mounting between flanges according to ANSI, BS, etc.

When ordering, please state the pressure rating of the counter flanges. See valve specification system page 8, code 11.

Actuators and accessories

The valves can be fitted with Somas manual, on/off or control actuators in accordance with the selection table.

The valves will be delivered as tested units ready for installation.

See sections 4 and 5 of the Somas catalogue for positioners, limit switches and solenoid valves.

Other types of actuators and accessories can be fitted in accordance with your specifications.

Seat design

The valves with a nominal size between DN 80-DN 300 have a metal seat (type Y) according to code D, while larger valves have a metal seat (3 pcs.) acc. to code C.

PTFE seat is available as an option.

Further technical information

Technical data for the materials used in the Somas valves, flange standard, steam data, etc. can be found in section 6 of the Somas catalogue.

Data sheet Si-203 shows butterfly valve type VSS for nominal sizes above DN 500.

Max. allowable pressure drops/torque figures

Maximum allowable pressure drops are valid at 20°C (see below).

Valve DN	PN	Max. pressure drop, bar at opening angle			Torque min. at ΔP		Torque min. at ΔP		Torque Max. shaft Nm
		0°	60°	80°	bar	Nm	bar	Nm	
80	25	25	13	4.4	≤ 10	100	> 10	120	150
100	25	25	13	4.4	≤ 10	120	> 10	165	220
125	25	25	15	5.8	≤ 10	180	> 10	220	220
150	25	25	9	2.7	≤ 10	200	> 10	250	300
200	25	25	4.3	1.1	≤ 10	250	> 10	290	350
250	25	25	3.6	1.05	≤ 10	400	> 10	500	600
300	25	20	3.6	1.05	≤ 10	500	> 10	620	750
350	25	20	3.6	1.09	≤ 8	800	> 8	1000	1200
400	25	20	4.7	1.43	≤ 8	1000	> 8	1350	1600
500	25	15	4.4	1.19	≤ 6	1900	> 6	2700	3250

Selection table, MTV / MTVF

Valve DN	Shaft dia. (mm)	Pneumatic actuators						Manual operation	
		Double acting		Spring return				Hand lever	Gear unit
		5,5 bar	4 bar	Spring closes		Spring opens			
				5,5 bar	4 bar	5,5 bar	4 bar		
80	20	A13	A21	A23-SC	A23-SC	A23-SO	A23-SOL	HSR020	M10/F07
100	20	A21	A22	A24-SC	A24-SC	A24-SO	A24-SOL	HSR020	M10/F07
125	20	A22	A22	A24-SC	A24-SC	A24-SO	A24-SOL	HSR020	M10/F07
150	25	A22	A22	A24-SC	A24-SC	A24-SO	A24-SOL	---	M10/F07
200	25	A22	A22	A24-SC	A24-SC	A24-SO	A24-SOL	---	M10/F07
250	30	A23	A31	A33-SC	A33-SC	A33-SO	A33-SOL	---	M12/F12
300	35	A31	A32	A33-SC	A33-SC	A33-SO	A33-SOL	---	M12/F12
350	40	A32	A32	A34-SC	A34-SC	A34-SO	A34-SOL	---	M12/F12
400	50	A32	A33	A43-SC	A43-SC	A43-SO	A43-SOL	---	M14/F14
500	60	A41	A42	A44-SC	A44-SC	A44-SO	A44-SOL	---	M15/F16



Variants

The standard Somas MTV valve is designed to be mounted between flanges, but is also available in lugged and flanged design.



MTV – "Lugs"-design

MTV – Flanged design (MTVF)

Temperature ranges for valve body, seat and shaft

Seat

	Max. temp.
A= PTFE (10 % carbon)	170°C
C= 1.4462 (metal seat, 3pcs)	350°C ¹
	550°C ²
D= 1.4470 (metal seat type Y)	350°C ¹
	550°C ²
E= 1.4547 (Avesta 254 SMO)	400°C
P= PTFE (fibreglass 15 %)	170°C
T= HiCo (High Cobalt alloy)	550°C

Shaft

	Max. temp.
A= 1.4460	150°C
B= 1.4460 (hard chromed)	350°C ¹
	550°C ²
C= 1.4460 (HiCo-coated)	350°C ¹
	550°C ²
F= 1.4435	150°C
G= 1.4435, hard chromed (316L)	550°C
K= 1.4539	350°C ¹
T= Titanium	150°C

Body

	Max. temp.
A= 2343-12	550°C
CF8M	500°C
E= CK-3MCuN	400°C

For ordering

State desired valve according to the valve specification system below as well as type of actuator, positioner and accessories.

¹ Check with SOMAS for temperatures between 350 and 550 °C
At higher pressures for example steam turbine applications.

² At lower pressures for example exhaust applications.

MTV - A 5 - A A D - A 1 1 - DN... - PN...

1 2 3 4 5 6 7 8 9 10 11

Valve specification system

- | | | |
|--|--|---|
| 1 Valve type
MTV = Standard
MTVF = Flanged design | 6 Material – seat
A = PTFE (10 % carbon ¹)
C = 1.4462 (metal seat, 3 pcs., DN 350–500)
D = 1.4470 (metal seat, type Y, DN 80–300)
L = HiNi (High Nickel alloy) | 9 Stuffing box
1 = Graphite
2 = PTFE |
| 2 Valve body design
A = Wafer design acc. to EN 558-1, series 20
F = "Lugs" design
L = Flanged design | 7 Material – shaft
A = 1.4460
B = 1.4460 (hard chromed) | 10 Valve size, DN |
| 3 Nominal pressure
5 = PN 25 | 8 Bearing – valve body/shaft
1 = Without bearing
6 = 1.4547
7 = 1.4539 | 11 Drilling, counter flanges |
| 4 Material – valve body
A = 2343-12 | | ¹ percentage by weight |
| 5 Material – disc
A = 2343-12 | | <i>Check with SOMAS for further combinations.</i> |

SOMAS reserves the right to make improvements without prior notice.



SOMAS[®]
P.O. Box 107, SE-661 23 SÄFFLE, SWEDEN
PHONE: +46 533 167 00
FAX: +46 533 141 36
E-mail: sales@somas.se
www.somas.se

Representative