



Butterfly valve Type VSS

Si-203 EN

Edition: 2008-05

Nominal pressure	– PN 10 - 25
Nominal size	– DN 80 - 1200
Material	– Stainless steel

SOMAS Butterfly Valve type VSS

- **Advanced triple eccentric design**
- **is designed for control and shut-off applications.**
- **is designed for applications up to 350 °C (662 °F).**
- **has a tightness class in accordance with IEC 534-4 Class V as standard.**
- **has a solid seat made of stainless steel.**
- **is designed to be mounted between flanges alt. with lugs.**

Option

- **PTFE-seat**
- **High temperature applications up to 550 °C (1022 °F)**

SOMAS butterfly valves, type VSS is used as a control, on/off and shut-off valve. The VSS valve is designed to handle a wide range of liquids, gases and steam within a broad temperature range.

The valves have an advanced triple eccentric design including a unique shape of the disc allows the use of a solid stainless steel seat. The solid seat remains un-affected by high flow velocities and temperatures. A good valve function is achieved even on difficult applications.

The seat is replaceable in alternative materials.

The VSS valve can be mounted between flanges and is also supplied in lugged design.

The SOMAS valves are delivered ready for installation and operation. The valve assemblies are delivered factory tested as complete units with actuators, positioners and accessories.





Tightness class

The tightness class is related to the chosen material in the seat ring.

Metal seat (Code C alt. D) IEC 534-4 Class V
 PTFE-seat (Code A) IEC 534-4 Class VI (Option)

Flow characteristics

100% Flow

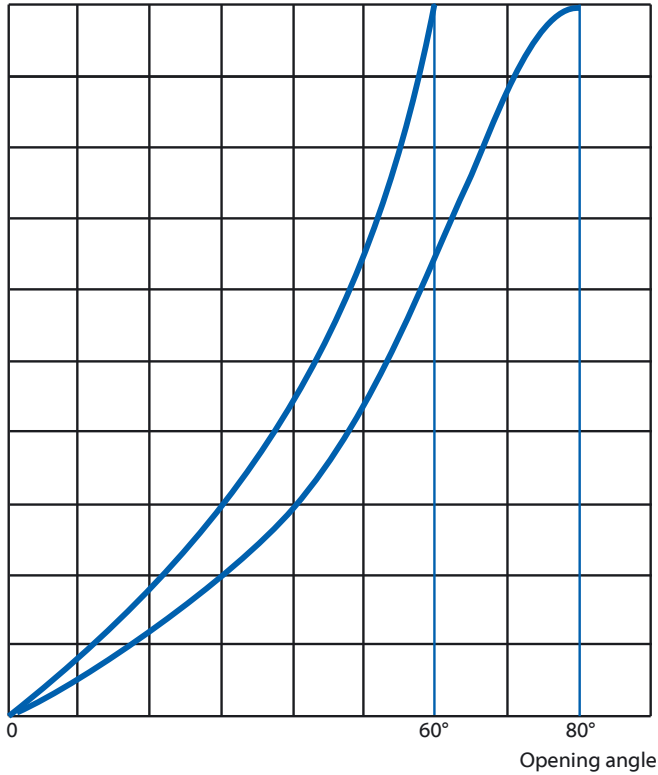

Factor F_{LP}

Factor	Opening angle								
	10°	20°	30°	40°	50°	60°	70°	80°	90°
F _{LP}	0.88	0.86	0.81	0.78	0.71	0.63	0.53	0.50	0.52

Factor F_{LP} is valid for all sizes

Liquid pressure recovery factor F_L

Factor	Opening angle								
	10°	20°	30°	40°	50°	60°	70°	80°	90°
F _L	0.88	0.86	0.82	0.80	0.74	0.68	0.61	0.60	0.59

Factor F_L is valid for all sizes

Pipe geometry factor F_p

Valve DN	Pipe DN	Opening angle								
		10°	20°	30°	40°	50°	60°	70°	80°	90°
80	100				0.99	0.99	0.96	0.93	0.91	0.93
	150	1.0	1.0	0.99	0.98	0.97	0.92	0.86	0.83	0.86
	200				0.97	0.94	0.88	0.81	0.77	0.81
100	150				0.98	0.97	0.93	0.88	0.84	0.88
	200	1.0	1.0	0.99	0.97	0.94	0.87	0.80	0.76	0.80
	250				0.96	0.93	0.85	0.77	0.72	0.77
125	150				0.98	0.95	0.91	0.91	0.88	0.91
	200	1.0	1.0	0.99	0.95	0.89	0.83	0.83	0.79	0.83
	250				0.93	0.86	0.78	0.78	0.74	0.78
150	200				0.98	0.95	0.91	0.91	0.88	0.91
	250	1.0	1.0	0.99	0.95	0.89	0.83	0.83	0.79	0.83
	300				0.93	0.86	0.78	0.78	0.74	0.78
200	250				0.99	0.98	0.96	0.93	0.91	0.93
	300	1.0	1.0	0.99	0.98	0.96	0.92	0.86	0.83	0.86
	350				0.97	0.94	0.88	0.81	0.77	0.81
250	300				0.99	0.99	0.97	0.95	0.93	0.95
	350	1.0	1.0	0.99	0.99	0.97	0.93	0.88	0.85	0.88
	400				0.98	0.95	0.90	0.83	0.80	0.83
300	350				0.99	0.99	0.98	0.96	0.95	0.96
	400	1.0	1.0	0.99	0.99	0.98	0.94	0.90	0.87	0.90
	500				0.98	0.96	0.91	0.85	0.82	0.85
350	400				0.99	0.99	0.97	0.95	0.93	0.95
	450	1.0	1.0	0.99	0.99	0.98	0.94	0.90	0.87	0.90
	500				0.98	0.96	0.91	0.85	0.82	0.85
400	450				0.99	0.99	0.99	0.97	0.97	0.97
	500	1.0	1.0	0.99	0.99	0.98	0.96	0.93	0.91	0.93
	600				0.98	0.96	0.91	0.85	0.82	0.85
450	500				0.99	0.99	0.99	0.98	0.97	0.98
	600	1.0	1.0	0.99	0.99	0.97	0.94	0.90	0.87	0.90
	700				0.98	0.95	0.90	0.84	0.80	0.84
500	600				0.99	0.99	0.99	0.98	0.98	0.98
	700	1.0	1.0	0.99	0.98	0.97	0.93	0.88	0.85	0.88
	800				0.98	0.95	0.89	0.83	0.79	0.83
600	700				0.99	0.99	0.98	0.96	0.95	0.96
	800	1.0	1.0	0.99	0.99	0.97	0.94	0.90	0.87	0.90
	900				0.98	0.96	0.91	0.85	0.81	0.85
700	800				0.99	0.99	0.98	0.97	0.96	0.96
	900	1.0	1.0	0.99	0.99	0.98	0.95	0.91	0.89	0.91
	1000				0.98	0.96	0.92	0.87	0.83	0.87
750	800				0.99	0.99	0.98	0.97	0.96	0.96
	900	1.0	1.0	0.99	0.99	0.98	0.95	0.91	0.89	0.91
	1000				0.98	0.96	0.92	0.87	0.83	0.87
800	900				0.99	0.99	0.98	0.97	0.96	0.97
	1000	1.0	1.0	0.99	0.99	0.98	0.94	0.93	0.90	0.93
	1200				0.98	0.96	0.91	0.85	0.81	0.84
900	1000				0.99	0.99	0.98	0.97	0.96	0.97
	1200	1.0	1.0	0.99	0.99	0.98	0.95	0.91	0.87	0.91
	1400				0.98	0.96	0.91	0.84	0.80	0.84
1000	1200				0.99	0.99	0.97	0.95	0.93	0.95
	1400	1.0	1.0	0.99	0.98	0.97	0.93	0.88	0.85	0.88
	1600				0.98	0.95	0.89	0.83	0.79	0.83
1200	1400				0.99	0.99	0.98	0.96	0.95	0.96
	1600	1.0	1.0	0.99	0.98	0.98	0.95	0.91	0.88	0.91
	1800				0.98	0.96	0.91	0.85	0.82	0.85



Capacity factor Kv and Resistance factor ξ

DN	Opening angle									
	10°	20°	30°	40°	50°	60°	70°	80°	90°	ξ 90°
80	14	31	48	73	108	165	203	235	205	1.18
100	21	45	70	107	158	240	324	375	326	1.13
125	35	75	116	177	262	400	520	605	523	1.06
150	50	108	168	256	379	580	780	905	784	0.98
200	89	193	299	457	675	1030	1390	1610	1397	0.99
250	142	307	476	727	1076	1650	2211	2555	2222	0.95
300	207	446	692	1058	1566	2400	3219	3720	3235	0.93
350	279	602	934	1427	2111	3230	4341	5020	4362	0.95
400	371	800	1242	1898	2809	4300	5775	6675	5805	0.91
450	482	1039	1618	2472	3661	5630	7555	8732	7594	0.90
500	584	1258	1951	2981	4413	6760	9071	10485	9117	0.90
600	853	1839	2851	4357	6448	9880	13256	15325	13223	0.76
700	1157	2494	3867	5909	8746	13400	17981	20780	18071	0.77
750	1157	2494	3867	5909	8746	13400	17981	20780	18071	0.77
800	1525	3289	5100	7793	11534	17670	23711	27405	23830	0.76
900	1945	4190	6495	9925	14690	22500	30195	34900	30345	0.80
1000	2395	5160	8005	12230	18100	26500	37205	43000	37390	0.81
1200	3450	7440	11540	18050	26095	37940	53645	62000	53910	0.81

Relation between Kv and Cv: $K_v = 0.86 C_v$

Pressure and temperature rating

PN	Temperature (°C)																				
	0-20	30	40	50	60	70	80	90	100	120	140	160	180	200	250	300	350	400	450	500	550
6	6	5.7	5.7	5.4	5.4	5.1	5.1	5.1	4.8	4.8	4.5	4.5	4.5	4.2	4.2	3.9	3.9	3.6	3.6	3.6	3.6
10	10	9.5	9.5	9	9	8.5	8.5	8.5	8	8	7.5	7.5	7.5	7	7	6.5	6.5	6	6	6	6
16	16	15.5	15	14.5	14.5	14	13.5	13.5	13	12.5	12.5	12	12	11.5	11	10.5	10	10	9.5	9.5	9.5
25	25	24.5	24	23	22.5	22	21.5	21	20.5	20	19.5	19	18.5	18	17.5	16.5	16	15.5	15.5	15	15

Use shaft material according to material code A for temperatures up to 150°C.

Use shaft material according to material code B for acids and hot gases above 150°C.

Max. allowable pressure drops/torque figures

Maximum allowable pressure drops are valid at 20 °C (see below).

Valve DN	PN	Max. pressure drop, bar at opening angle			Torque min. at ΔP		Torque min. at ΔP		Torque Max. shaft Nm
		0°	60°	80°	bar	Nm	bar	Nm	
80	25	25	13	4.4	≤ 10	100	> 10	120	150
100	25	25	13	4.4	≤ 10	120	> 10	165	220
125	25	25	15	5.8	≤ 10	180	> 10	220	220
150	25	25	9	2.7	≤ 10	200	> 10	250	300
200	25	25	4.3	1.1	≤ 10	250	> 10	290	350
250	25	25	3.6	1.05	≤ 10	400	> 10	500	600
300	25	20	3.6	0.93	≤ 10	500	> 10	620	750
350	25	20	3.6	1.09	≤ 8	800	> 8	1000	1200
400	25	20	4.7	1.43	≤ 8	1000	> 8	1350	1600
450	25	16	3.4	0.95	≤ 7	1350	> 7	1900	2250
500	25	15	4.4	1.19	≤ 6	1900	> 6	2700	3250
600	25	10	3.9	1.13	≤ 5	2400	> 5	2900	3500
700	25	8	2.7	0.75	≤ 4	3200	> 4	4200	5000
750	25	8	2.7	0.75	≤ 4	3200	> 4	4200	5000
800	25	8	2.6	0.75	≤ 4	4000	> 4	5000	6000
900	10	7	2.4	0.65	≤ 3	4800	> 3	5800	6900
1000	10	6	2.2	0.55	≤ 3	6000	> 3	7500	9000
1200	6-10	4.5	1.8	0.45	≤ 3	7500	> 3	9000	10800

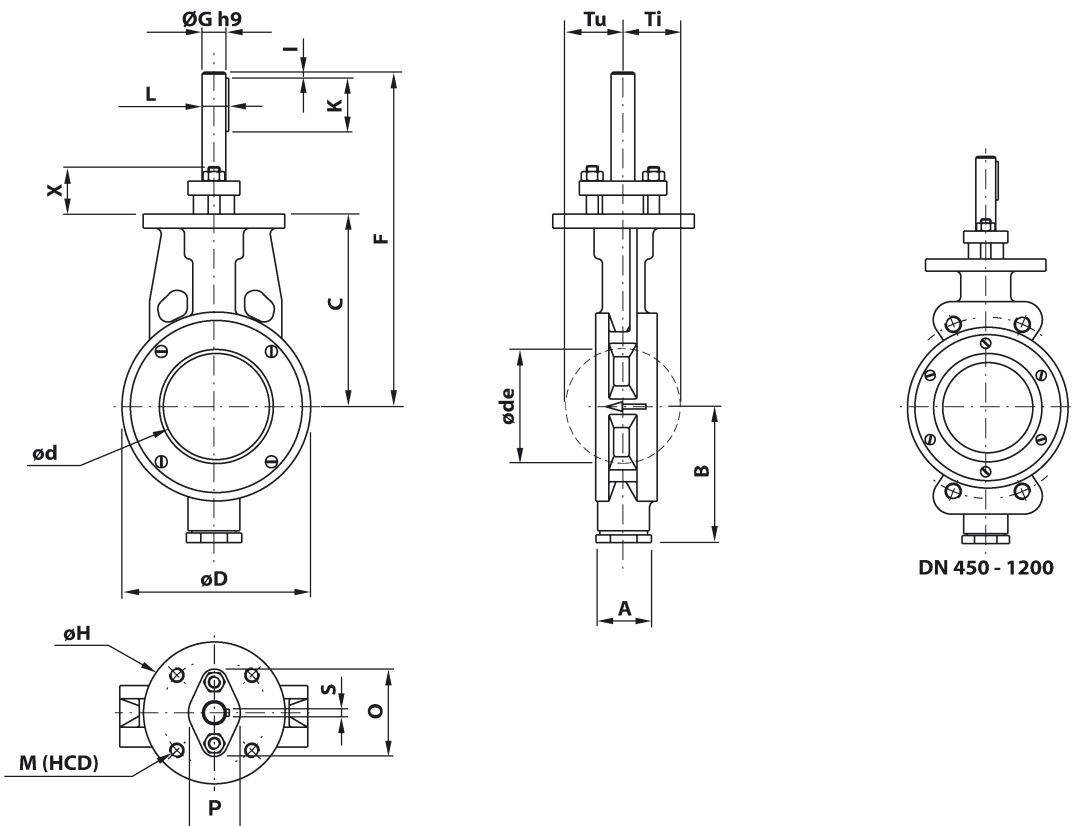

A = Mounting dimension according to EN 558-1 series 20 and EN 558-2 series 20

Butterfly valve type VSS																					
DN	A	B	C	$\varnothing d$	$\varnothing de$	$\varnothing D$	F	$\varnothing G$	$\varnothing H$	I	K	L	M (HCD)	O	P	S	X	Tu	Ti	Weight	
80	50	105	150	70	60	133	270	20	120	5	45	22.5	M12	90	74	44	6	40	41	37	7
100	52	115	163	90	86	160	283	20	120	5	45	22.5	M12	90	74	44	6	40	52	48	9
125	56	130	175	116	110	190	295	20	120	5	45	22.5	M12	90	74	44	6	40	64	60	11
150	56	150	195	140	138	215	315	25	120	5	45	28	M12	90	78	50	8	40	77	73	14
200	60	180	235	187	186	270	355	25	120	5	45	28	M12	90	78	50	8	40	100	96	19
250	68	205	275	236	235	324	410	30	150	5	60	33	M12	120	92	58	8	50	124	120	30
300	78	240	290	285	285	375	425	35	150	5	50	38	M12	120	100	64	10	50	149	145	43
350	78	320	315	331	330	435	450	40	150	5	50	43	M12	120	108	70	12	50	172	167	56
400	102	360	340	382	380	490	550	50	150	10	80	53.5	M12	120	124	82	14	50	199	194	85
450	114	385	370	429	425	535	580	50	150	10	80	53.5	M12	120	124	82	14	50	223	217	109
500	127	415	400	479	475	590	610	60	200	10	90	64	M16	160	147	96	18	60	249	242	150
600	154	475	450	579	575	695	675	70	200	10	110	74.5	M16	160	162	112	20	60	300	292	221
700	165	530	515	674	675	800	730	70	200	10	110	74.5	M16	160	162	112	20	60	343	343	300
750	165	545	538	680	675	860	765	70	200	10	110	74.5	M16	160	162	112	20	60	343	343	360
800	190	600	600	774	775	915	825	80	200	10	120	85	M16	160	183	120	22	76	393	393	420
900	203	640	645	900	875	1010	890	80	200	10	120	85	M20	160	183	120	22	76	449	449	530
1000	216	705	730	975	975	1110	975	80	250	10	120	85	M20	205	200	200	22	85	498	488	710
1200	254	805	800	1175	1175	1300	1055	100	250	10	125	106	M20	205	200	200	28	85	598	588	1140

$\varnothing de$ = Necessary free diameter for the disc under movement

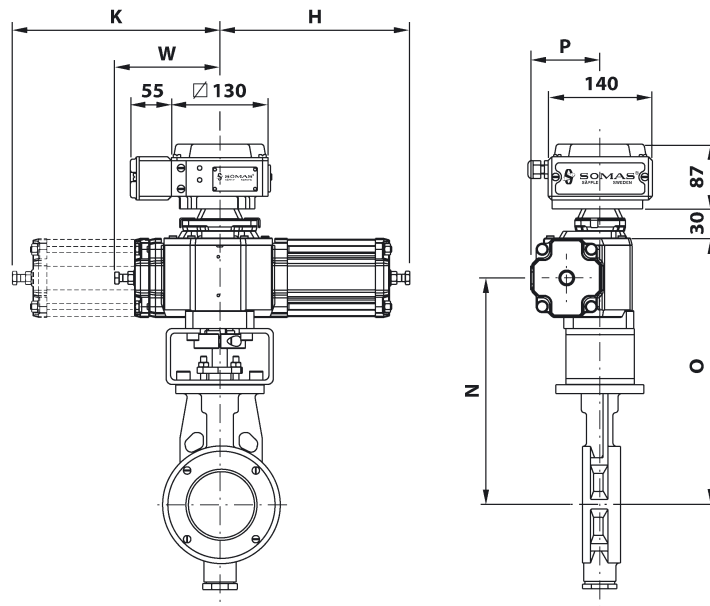

Butterfly valve, type VSS with actuator type A-DA										Actuator type A-SC/SO									
DN	Type	H	K	N	O	P	R	W	Weight	DN	Type	H	K	N	O	P	R	W	Weight
80	A13	250	---	275	325	83	106	90	13	80	A23-X	415	---	295	360	117	152	140	24
80	A21	255	---	295	360	94	106	140	17	100	A24-X	415	---	305	370	117	152	140	25
100	A21	255	---	305	370	94	106	140	19	125	A24-X	415	420	320	385	117	152	---	38
100	A22	255	260	305	370	94	106	---	20	150	A24-X	415	420	340	405	117	152	---	41
125	A22	255	260	320	385	94	106	---	22	200	A24-X	415	420	380	445	117	152	---	46
150	A22	255	260	340	410	94	106	---	25	250	A33-X	660	---	470	560	185	230	215	88
200	A22	255	260	380	445	94	106	---	30	300	A33-X	660	---	485	575	185	230	215	101
250	A23	305	---	420	485	117	152	140	47	350	A34-X	665	680	525	610	185	230	---	145
250	A31	380	---	470	560	144	152	215	55	400	A43-X	920	---	615	740	280	355	315	250
300	A31	380	---	485	575	144	152	215	68	450	A43-X	920	---	645	770	280	355	315	275
300	A32	380	395	485	575	144	152	---	74	500	A44-X	925	935	675	600	280	355	---	370
350	A32	380	395	525	600	144	152	---	87	600	A44-X	925	935	725	850	280	355	---	440
400	A32	380	395	570	655	144	152	---	116	700	A44-SO	925	935	790	915	280	355	---	515
400	A33	470	---	570	655	185	230	215	123										
450	A34	470	485	600	685	185	230	---	165										
450	A41	550	---	645	770	210	230	315	185										
500	A41	550	---	675	800	210	230	315	230										
500	A42	545	560	675	800	210	230	---	245										
600	A41	550	---	725	850	210	230	315	300										
600	A42	545	560	725	850	210	230	---	315										
700	A42	545	560	790	915	210	230	---	390										
750	A42	545	560	810	940	210	230	---	455										
800	A42	545	560	810	1000	280	355	---	515										
800	A43	680	---	875	1000	280	355	370	570										
900	A51	745	---	965	1150	315	355	370	735										
1000	A51	745	---	1050	1235	315	355	370	920										
1000	A52	745	760	1050	1235	315	355	---	955										
1200	A51	745	---	1120	1305	315	355	370	1350										
1200	A52	745	760	1120	1305	315	355	---	1385										

For units with the positioner type SP405, add 2 kg.

For units with the positioner type SPE405, add 3 kg.

X = SC - Spring closes

X = SO - Spring opens

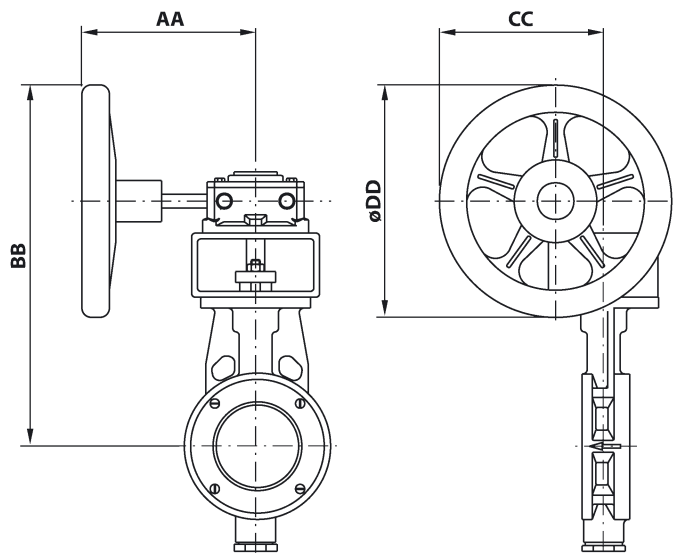
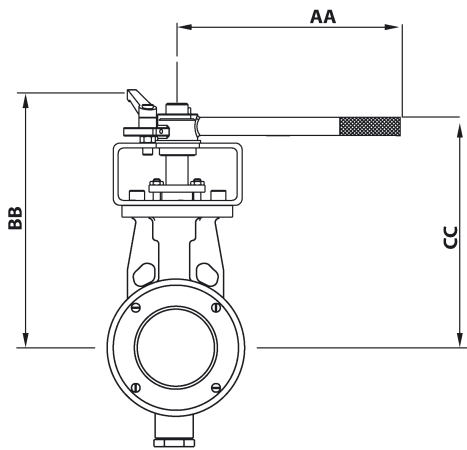

Butterfly valve type VSS with hand lever					
DN	Type	AA	BB	CC	Weight
80	HSR20	355	275	245	10
100	HSR20	355	288	258	12
125	HSR20	355	300	270	14

Butterfly valve type VSS with gear unit						
DN	Type	AA	BB	CC	øDD	Weight
80	M10/F07	185	380	180	250	15
100	M10/F07	185	395	180	250	17
125	M10/F07	185	405	180	250	19
150	M10/F07	185	425	180	250	22
200	M10/F07	185	465	180	250	27
250	M12/F12	225	540	220	300	42
300	M12/F12	225	555	220	300	55
350	M12/F12	225	580	220	300	68
400	M14/F14	250	685	265	350	106
450	M14/F14	250	715	265	350	130
500	M15/F16	365	875	430	610	186
600	M15/F16	365	925	430	610	285
700	M20/F25	460	905	450	610	363
750	M20/F25	460	930	450	610	424
800	MJF/S5	530	970	485	610	426
900	MJF/S5	530	1035	485	610	640
1000	MJF/S5	530	1120	485	610	820
1200	MJF/S5	530	1250	485	610	1250

Actuators and accessories

The valves can be fitted with SOMAS manual, on/off or control actuators in accordance with the selection table.

The valves will be delivered as tested units ready for installation.

See sections 4 and 5 of the SOMAS catalogue for positioners, limit switches and solenoid valves.

Other types of actuators and accessories can be fitted in accordance with your specifications.

Selection table, VSS

Valve DN	Shaft Ø (mm)	Pneumatic actuators						Manual operation	
		Double acting		Spring return				Hand lever	Gear unit
		5.5 bar	4 bar	Spring closes		Spring opens			
				5.5 bar	4 bar	5.5 bar	4 bar		
80	20	A13	A21	A23-SC	A23-SC	A23-SO	A23-SOL	HSR020	M10/F07
100	20	A21	A22	A24-SC	A24-SC	A24-SO	A24-SOL	HSR020	M10/F07
125	20	A22	A22	A24-SC	A24-SC	A24-SO	A24-SOL	HSR020	M10/F07
150	25	A22	A22	A24-SC	A24-SC	A24-SO	A24-SOL		M10/F07
200	25	A22	A22	A24-SC	A24-SC	A24-SO	A24-SOL		M10/F07
250	30	A23	A31	A33-SC	A33-SC	A33-SO	A33-SOL		M12/F12
300	35	A31	A32	A33-SC	A33-SC	A33-SO	A33-SOL		M12/F12
350	40	A32	A32	A34-SC	A34-SC	A34-SO	A34-SOL		M12/F12
400	50	A32	A33	A43-SC	A43-SC	A43-SO	A43-SOL		M14/F14
450	50	A41	A34	A43-SC	A43-SC	A43-SO	A43-SOL		M14/F14
500	60	A41	A42	A44-SC	A44-SC	A44-SO	A44-SOL		M15/F16
600	70	A41	A42	A44-SC		A44-SO	A44-SOL		M20/F25
700	70	A42	A42			A44-SO			M20/F25
750	70	A42	A42						M20/F25
800	80	A42	A43						MJF/S5
900	80	A51	A51						MJF/S5
1000	80	A51	A52						MJF/S5
1200	100	A51	A52						MJF/S5



Flange standard

SOMAS butterfly valve type VSS in this data sheet is of wafer type for mounting between flanges PN 10-25.

The valve can also be delivered with "lugs"

The valve can also be drilled for mounting between flanges according to ANSI, BS, etc.

When ordering, please state the pressure rating of the counter flanges. See valve specification system page 8, code 11.

Seat design

The valves with a nominal size between DN 80-DN 800 have a metal seat according to code C, while larger valves have a metal seat (type Y) according to code D.

PTFE and HiNi seat is available as an option.

Also check the valve specification system (code 6) to find further seat alternatives.

Supplemental information

Gaskets

Note: Use gaskets with the correct inside diameter to ensure that pressure is applied on the cover plate.

For mounting between flanges according to PN 10-25, the inside gasket diameter should not exceed the dimensions specified in the standard DIN-EN 1514-1. See the table below.

Valve DN	Max. Inside dia. di (mm)	Outside dia. (dy) (mm)		
		PN 10	PN 16	PN 25
80	89	142	142	142
100	115	162	162	168
125	141	192	192	194
150	169	218	218	224
200	220	273	273	284
250	273	328	329	340
300	324	378	384	400
350	356	438	444	457
400	407	489	495	514
450	458	539	555	564
500	508	594	617	624
600	610	695	734	731
700	712	810	804	833
800	813	917	911	942
900	915	1017	1011	1042
1000	1016	1124	1128	1154
1200	1220	1341	1342	1364

Further technical information

Technical data for the materials used in the SOMAS valves, flange standard, steam data, etc. can be found in section 6 of the SOMAS catalogue.

See also data sheet Si-205, that shows butterfly valve type MTV (DN 80–500). For valves with pressure class PN 50, see data sheet Si-204.

For mounting between flanges according to ANSI 150 dimensions according to the standard ANSI B 16.21 RF are valid where the following dimensions refer to the gasket:

Valve DN	Max. Inside dia. di (mm)	Outside dia. (dy) (mm) ANSI 150
80	89	136
100	114	174
125	141	196
150	168	222
200	219	279
250	273	340
300	324	410
350	356	451
400	406	515
450	457	550
500	508	606
600	610	720
750	762	857



Variants

The standard VSS valve is designed to be mounted between flanges, but is also available in lugged design.



For ordering

State desired valve according to the valve specification system below as well as type of actuator, positioner and accessories.

Valve specification system

VSS - A 5 - A A C - A 1 1 - DN... - PN...

1	2	3	4	5	6	7	8	9	10	11
1 Valve type	2 Valve body design	3 Nominal pressure	4 Material – valve body	5 Material – disc	6 Material – seat	7 Material – shaft	8 Bearing – valve body/shaft	9 Stuffing box	10 Valve size, DN	11 Drilling, counter flanges
	A = Wafer design according to EN 558-1, Serie 20 F = "Lugs" design	1 = PN 6 2 = PN 10 5 = PN 25 6 = PN 50	A = 2343-12 (CF8M) E = CK-3MCuN	A = 2343-12* B = 2343-12* (hard chromed) C = 2343-12* (HiCo coated)	A = PTFE (10 % carbon) C = 1.4462 (metal seat, 3 pcs.) D = 1.4462 (metal seat, type Y, DN 900-) E = 1.4547 L = HiNi (High Nickel Alloy) T = HiCo (High Cobalt Alloy)	A = 1.4460 B = 1.4460 (hard chromed) C = 1.4460 (HiCo coated) H = 1.4429 J = 1.4547	1 = Without bearing 3 = HiCo (High Cobalt Alloy) 6 = 1.4547 7 = 1.4539	1 = Graphite 2 = PTFE		

*1.4436 for DN 80-200

Check with SOMAS for further combinations.

Temperature ranges for valve body, seat and shaft

Seat	Max. temp.
A = PTFE (10 % carbon)	170 °C
C = 1.4462 (metal seat, 3 pcs.)	350 °C ¹
	550 °C ²
D = 1.4470 (metal seat type Y)	350 °C ¹
	550 °C ²
E = 1.4547	400 °C
P = PTFE (fibre glass 15 %)	170 °C
T = HiCo (High Cobalt Alloy)	550 °C
Shaft	Max. temp.
A = 1.4460	150 °C
B = 1.4460 (hard chromed)	350 °C ¹
	550 °C ²
C = 1.4460 (HiCo coated)	350 °C ¹
	550 °C ²
F = 1.4435	150 °C
G = 1.4435 (hard chromed)	550 °C
K = 1.4539	350 °C ¹
T = Titanium	150 °C
Valve body	Max. temp.
A = 2343-12	550 °C
CF8M	500 °C
E = CK-3MCuN	400 °C

¹ Check with SOMAS for temperatures between 350 and 550 °C
At higher pressures for example steam turbine applications

² At lower pressures for example exhaust applications

SOMAS reserves the right to make improvements without prior notice.



SOMAS[®]
P.O. Box 107, SE-661 23 SÄFFLE, SWEDEN
PHONE: +46 533 167 00
FAX: +46 533 141 36
E-mail: sales@somas.se
www.somas.se

Representative